

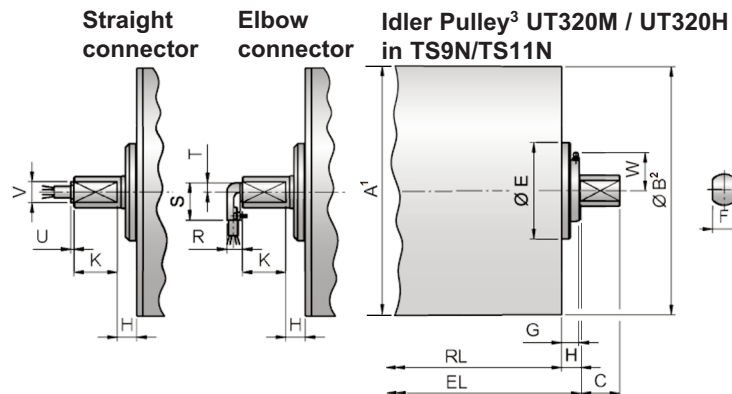

Motorized Pulley 320L, 320M & 320H, Ø 12.64 in. (321 mm)

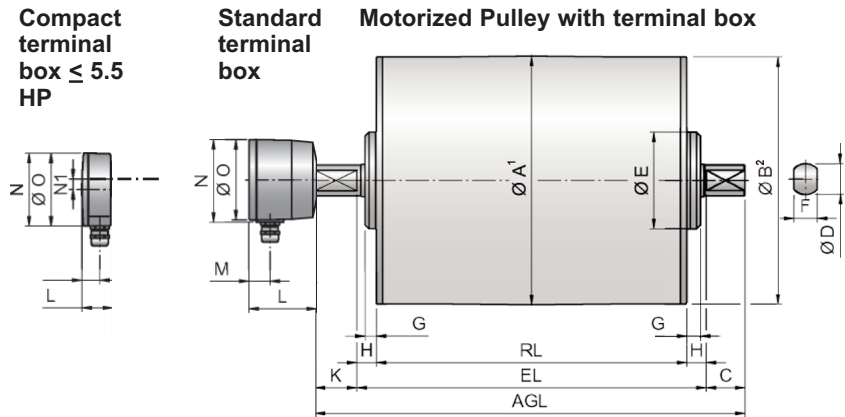

| Model | Motorized Pulley or idler Pulley | | | | | | | | | | | Standard terminal box | | | | Compact terminal box ≤ 5.5 HP | | | | Straight connector ≤ 5.5 HP | | Elbow connector ≤ 5.5 HP | | |
|--------|----------------------------------|-------|------|------|------|------|------|--------|------|------|------|-----------------------|------|------|------|-------------------------------|------|------|------|-----------------------------|------|--------------------------|------|------|
| | A | B | C | D | E | F | G | G | H | K | W | L | M | N | O | L | M | N | N1 | U | V | R | S | T |
| | in | in | in | in | in | in | in | TS9/11 | in | in | in | in | in | in | in | in | in | in | in | in | in | in | in | in |
| 320L | 12.72 | 12.56 | 1.97 | 1.57 | 3.78 | 1.18 | 0.59 | 0.75 | 0.98 | 2.13 | — | — | — | — | 1.61 | 0.95 | 3.74 | 0.55 | 0.16 | 1.06 | 0.79 | 1.89 | 0.47 | |
| 320M | 12.64 | 12.56 | 1.97 | 1.57 | 4.92 | 1.18 | 0.69 | 0.89 | 0.98 | 2.13 | — | 3.43 | 1.06 | 4.21 | 4.13 | 1.61 | 0.95 | 3.74 | 0.55 | 0.16 | 1.06 | 0.79 | 1.89 | 0.47 |
| 320H | 12.64 | 12.56 | 1.97 | 1.97 | 5.83 | 1.57 | 0.43 | 0.81 | 0.98 | 2.17 | — | 3.43 | 1.06 | 4.21 | 4.13 | 1.61 | 0.95 | 3.74 | 0.55 | 0.16 | 1.06 | 0.79 | 1.89 | 0.47 |
| UT320M | 12.64 | 12.64 | 1.97 | 1.57 | 4.92 | 1.18 | 0.57 | 0.89 | 0.98 | — | 2.05 | | | | | | | | | | | | | |
| UT320H | 12.64 | 12.64 | 1.97 | 1.97 | 5.83 | 1.57 | 0.43 | 0.81 | 0.98 | — | 2.05 | | | | | | | | | | | | | |

- 1 A dimension is outer diameter of unlagged pulley shell at pulley centerline.
- 2 B dimension is outer diameter of unlagged pulley shell at each end of shell.
- 3 Idler pulley shown is non-crowned TS9N/TS11N version with regreasable seals.

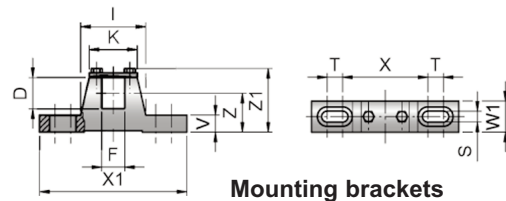

| Motorized Pulleys | Material | Bracket Size | Part Number | Dimensions | | | | | | | | | | | | | Weight |
|-------------------|-----------------|--------------|-------------|------------|------|------|------|------|------|------|------|------|------|------|------|------|--------|
| | | | | D | F | I | K | S | T | V | W1 | X | X1 | Z | Z1 | lbs | |
| 320L & 320M | Steel painted | KL41-HD | 6YA0K | 1.57 | 1.18 | 3.31 | 2.44 | 0.55 | 0.79 | 0.87 | 1.57 | 4.33 | 7.48 | 1.97 | 3.27 | 4.63 | |
| | Steel Ni plated | | 6YA0W | | | | | | | | | | | | | | |
| | Stainless steel | | 6YA0U | | | | | | | | | | | | | | |
| 320H | Steel painted | KL42 | 6YA0J | 1.97 | 1.57 | 4.76 | 3.54 | 0.71 | 1.18 | 0.98 | 1.97 | 5.91 | 9.84 | 2.76 | 4.33 | 9.92 | |
| | Steel Ni plated | | 6YA0S | | | | | | | | | | | | | | |