

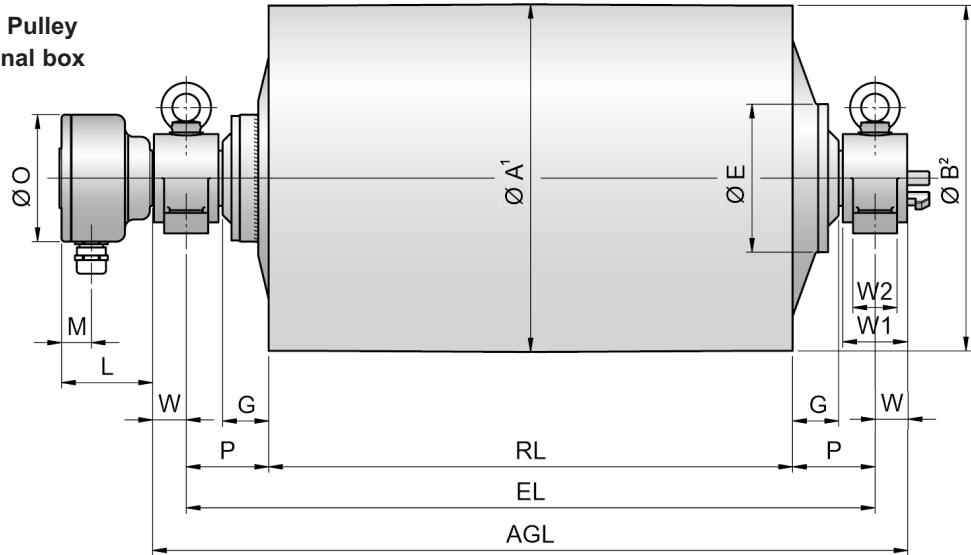

Motorized Pulley 630M & 630H, Ø 24.80 in. (630 mm)

Motorized Pulley with terminal box



Idler Pulley³ UT500H / UT502H

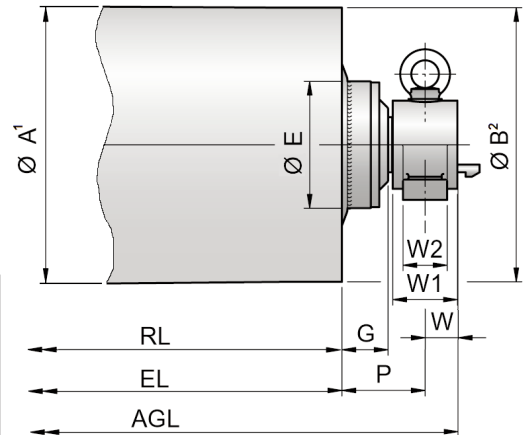

Model	Motorized Pulleys or Idler Pulleys									
	A in	B in	C in	D ⁴ in	E in	G in	L in	M in	O in	P in
630M	24.80	24.65	-	2.56	7.56	3.74	3.94	1.42	6.14	5.91
630H	24.80	24.65	-	3.54	10.55	3.46	6.50	2.13	9.06	5.91
UT500H	19.72	19.72	-	2.56	9.25	3.74	-	-	-	5.91
UT502H	19.72	19.72	-	3.54	8.90	3.35	-	-	-	5.91

- 1 A dimension is outer diameter of unlagged pulley shell at pulley centerline.
- 2 B dimension is outer diameter of unlagged pulley shell at each end of shell.
- 3 Idler pulley shown is non-crowned version.
- 4 D dimension is shaft diameter.

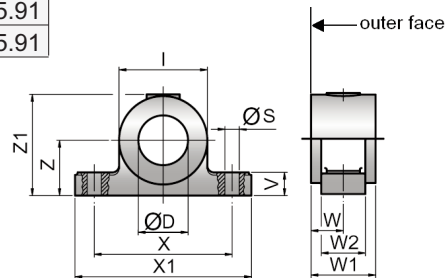

Mounting brackets*

Motorized Pulleys & Idler Pulleys Model	Material	Bracket Size*	Dimensions												Weight lbs
			D in	I in	S in	V in	W in	W1 in	W2 in	X in	X1 in	Z in	Z1 in		
630M & UT500H	Cast iron	AL65 / ALO65	2.56	4.53	0.91	1.34	1.85	3.54	2.36	7.09	9.45	3.15	5.55	17.64	
630H & UT502H	Cast steel	AL90 / ALO90	3.54	6.30	1.02	1.65	2.40	4.61	3.15	9.84	12.60	3.94	7.20	41.89	

* Type AL bracket has gib key. Type ALO has no gib key. See position 69 on page 64.