

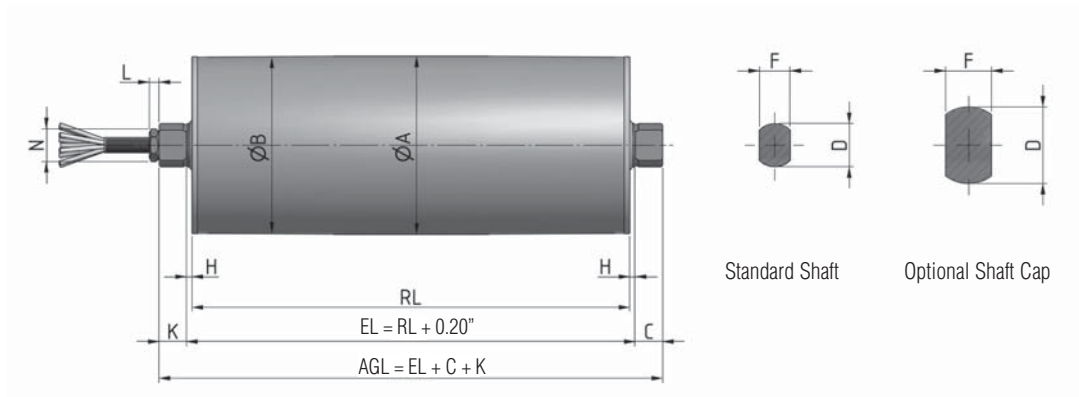

Motorized Pulley 80LS

Ø 3.21 in. (80 mm), with steel helical gearbox



Standard Motorized Pulley with straight stainless steel connector

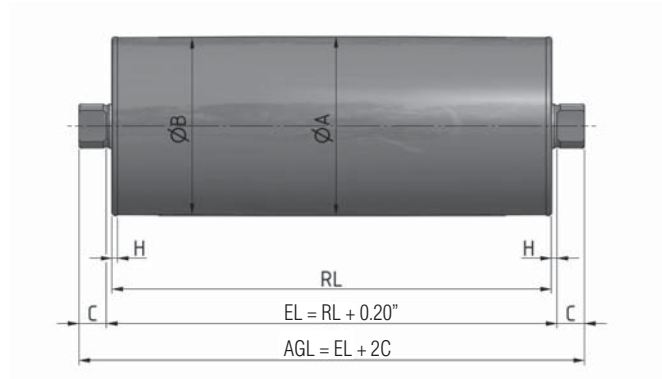

Idler Pulley

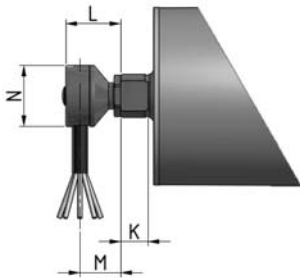

Standard shaft with stainless steel elbow connector

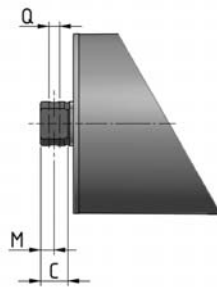

Cross-drilled and threaded shaft.

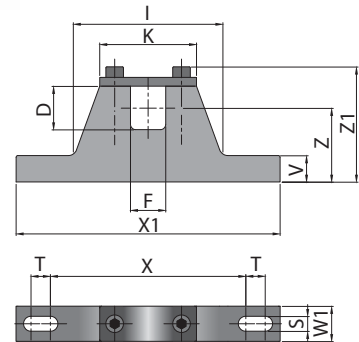

MC = Mounting bracket center-to-center spacing = $RL + 0.59$ "

Mounting bracket

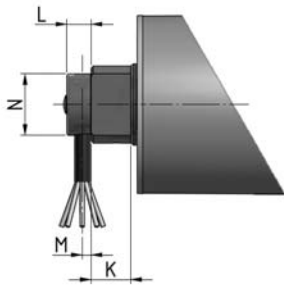

Shaft cap with stainless steel elbow connector

Motorized Pulley 80LS

Ø 3.21 in. (80 mm), with steel helical gearbox



Dimensions for Motorized Pulley 80LS

Type/Option	A in	B in	C in	D in	E in	F in	G in	H in	K in	L in	M in	N in	Q in	T in
Standard shaft with ss straight connector	3.21	3.17	0.49	0.79		0.55		0.1	0.49	0.18		0.59		
Standard shaft with ss elbow connector									0.49	0.98	0.73	1.1		
Cross-drilled and threaded shaft			0.49								0.25		M6	
Shaft cap with ss elbow connector									0.71	0.43	0.16	1.1		

Revised Dimensions for options

The following options increase the minimum roller length (RL)

Option	Optional RL min.
Electromagnetic brake	Standard RL min. + 1.97in
Encoder	Standard RL min. + 1.97in

Dimensions, materials, and weights for Mounting Brackets

Motorized Pulley	Standard Material	Optional Material	D [in]	F [in]	I [in]	K [in]	S [in]	T [in]	V [in]	W1 [in]	X [in]	X1 [in]	Z [in]	Z1 [in]	Thread	Weight [lbs]
80LS	Aluminum	Stainless steel	0.79	0.55	2.24	1.50	0.26	0.35	0.47	0.39	2.83	4.06	1.38	2.17	M6	0.3/0.5

Standard weights for Motorized Pulley 80LS

Power HP	Poles	Standard weight [lbs] for standard RL [in]													
		7.87	9.84	11.81	13.78	15.75	17.72	19.69	21.65	23.62	25.59	27.56	31.5	35.43	39.37
0.027	8	---	7.5	8.5	9.5	10.5	11.5	12.5	13.5	14.5	15.5	16.5	17.5	18.5	19.5
0.047	4	6.0	7.0	8.0	9.0	10.0	11.0	12.0	13.0	14.0	15.0	16.0	17.0	18.0	19.0
0.09	4	---	7.5	8.5	9.5	10.5	11.5	12.5	13.5	14.5	15.5	16.5	17.5	18.5	19.5
	2	6.0	7.0	8.0	9.0	10.0	11.0	12.0	13.0	14.0	15.0	16.0	17.0	18.0	19.0
0.16	2	---	7.5	8.5	9.5	10.5	11.5	12.5	13.5	14.5	15.5	16.5	17.5	18.5	19.5