



Motorized Pulley 113LS

Ø 4.53 in. (113 mm), with helical steel gearbox

Spare Parts List and Sectional Drawings

1	Pulley shell	15.1*	Rotor assembly	53.1	Pressure nipple
2	Bearing housing	23	Rear flange	68	Key
3	Bearing housing	24	Double lip seal	95	Straight connector
8	Gearbed rim	26	Ball bearing	140	Deflection seal
12*	Gearbox (3 stage shown)	29	Ball bearing	146	Washer
13	Front shaft	40	Hexagon socket screw	196	Key
14	Rear shaft	51	Oil plug	200	Rubber seal
15*	Stator	52	Oil plug with magnet	201	Encoder (if applicable)

113LS Standard: 3 stage gearbox with power cord

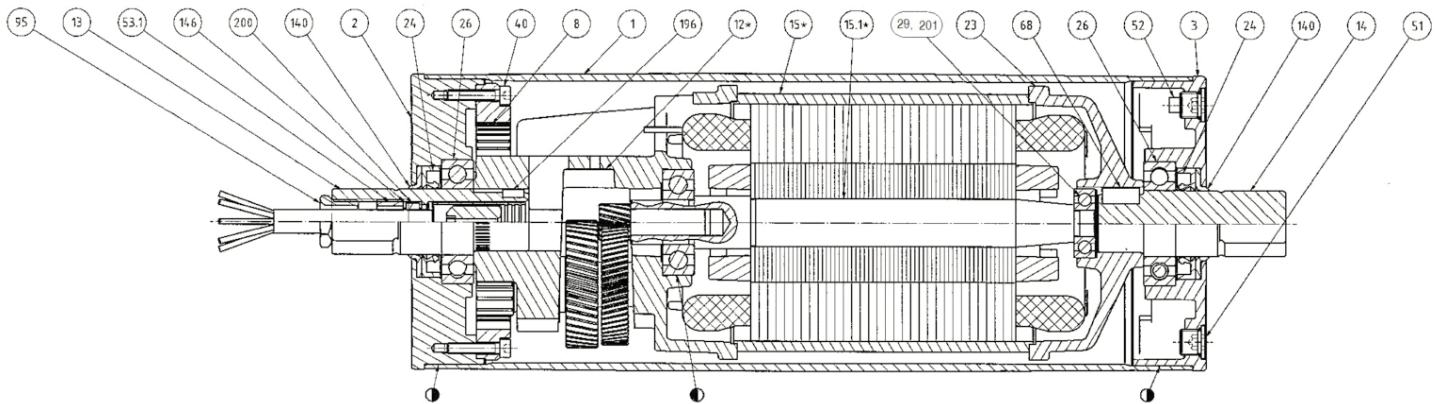

* Variable parts for other speeds and powers

Motor stator cross section

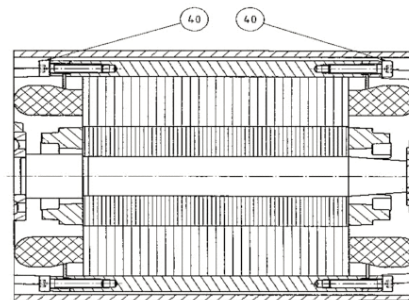

Motorized Pulley 113LS

Ø 4.53 in. (113 mm), with helical steel gearbox



Spare Parts List and Sectional Drawings

1	Front shaft	103	Screw	146	Washer
5	Bearing housing complete w/geared rim	110	Screw	148	Washer
10	Terminal box - bottom part	111	Screw	200	Rubber seal
11	Terminal box cover	136	O-ring/Rubber seal	229	WAGO clamp terminals
53	Cable side nipple (cable option)	138	Rubber seal	230	Fixing bolts
53.1	Nipple (terminal box)	140	Deflection seal		
63	Ball bearing	142	Double lip seal		

113LS Standard: with terminal box

