



Motorized Pulley 220M & 220H, Ø 216 mm

To match your requirements in diameter 216 mm, our product range offers two different loading performances for your **BULK** applications:

- **M** for Medium-duty
- **H** for Heavy-duty

You have a choice.

Therefore, it is important to notice the differences to choose the right type of pulley for the right application based on estimated belt tension (radial load) = T1+T2. The actual radial load **MUST** be **LESS** than the max. allowable radial load shown in this catalogue.

Be aware of increased belt tensions using **multi-ply thick heavy belts** and/or larger belt widths.

If you do not find the belt tension needed in this diameter, you might have to choose a larger one.

M for Medium-duty

The internal parts of 220M are designed to match irregular working conditions in applications such as mobile crushing & screening, cement & concrete plants, mobile conveyors and open stone & gravel pits.

220M provide sufficient belt tension.

H for Heavy-duty

A reinforced 3-stage-gearbox provides 220H with the necessary strength needed for low speeds, high torque and the listed belt tension.

220H is popular in re-cycling (hand sorter conveyors), bunker discharge conveyors and where a combination of slow speed and high torque is required.

STANDARD SPECIFICATION of Motorized Pulley

- Crowned mild steel Ø 216 mm steel shell treated with anti-rust wax
- Powder coated cast iron bearing housings
- Mild steel shafts treated with anti-rust wax
- Shaft sealing system - degree of protection IP66/67 (EN60034-5)
- Compact powder coated die cast aluminium terminal box
- Larger powder coated die cast aluminium terminal box ≥ 5.5 kW
- 3-phase induction motors with thermal protector
- Voltage: Wide range & dual voltage (Star/Delta). Most common voltages available. Please specify!
- Motor winding insulation Class F
- Dynamically balanced rotor
- One out of two oil plugs fitted with a magnet to filter the oil
- Oil change recommended every 10,000 operational hours
- Minimum RL. Please refer to pages 23-24
- Maximum RL – Please inquire!
- Non standard RL's available
- To be used in horizontal positions ± 5 degree only!

Please note:

- Straight or elbow connector available
- Parallel shell available. Diameter equal to dimension Ø A
- Two speed motors on request
- Special speed available on request
- Motorized Pulleys for non-horizontal positions available on request
- The high speed of 2-pole motors can cause higher noise levels and are therefore not recommended in noise sensitive areas
- Environmental considerations: page 72
- Technical precautions: pages 76-86
- Optional extras: page 21 and back cover
- Connection Diagrams: pages 94-96.

STAINLESS STEEL options

TS9N

- Stainless steel shell – AISI 304 range
- Stainless steel shafts – AISI 303/4 range
- Stainless steel covered bearing housings – AISI 316 range
- Stainless steel oil plugs – AISI 304 range – one out of two with magnet
- Stainless steel exterior bolts – AISI 304 range
- Re-greasable labyrinth seals with grease nipples in stainless steel – AISI 304 range
- Shaft sealing system – degree of protection IP66/67 (EN60034-5).

TS10N

- As TS9N, but WITHOUT re-greasable labyrinth seals.

SEMI-RUST-FREE options

TS11N

- As TS9N, but with crowned mild steel Ø 216 mm steel shell treated with anti-rust wax.

TS12N

- As TS10N, but with crowned mild steel Ø 216 mm steel shell treated with anti-rust wax.

Other Options:

- FDA & USDA food grade recognized oil and grease are NOT included in TS9N to TS12N, but available on request
- Complete Motorized Pulleys in acid resistant stainless steel – AISI 316 range – on request.

Electrical connection options:

- Salt water resistant powder coated aluminium terminal box with zinc plated exterior bolts
- Stainless steel terminal box – AISI 304 range (max. 4 kW)
- Straight stainless steel connector with flying lead – AISI 304 range.

Please specify required TS-number when ordering!



OPTIONAL EXTRAS

Motorized Pulley 220M & 220H

Specification

220M & 220H

Total stainless steel option AISI 304 range	TS9N	Re-greasable labyrinth seals!	x
Total stainless steel option AISI 304 range	TS10N	Standard seals!	x
Semi-rust free option	TS11N	Re-greasable labyrinth seals!	x
Semi-rust free option	TS12N	Standard seals!	x
Food grade oil & grease - FDA & USDA recognized - available on request			x
Dust explosion proof Motorized Pulleys - ATEX 95 - Zone 22 - for applications handling of dusty grain etc. According to European Directive 94/9/EC.			On request!
TOTAL acid resistant stainless steel option - AISI 316			x
Re-greasable labyrinth seals - mild steel			x
Black rubber lagging - STANDARD specifications: - Smooth lagging - Hardness 60 ±5 Shore A - Diamond lagging - Hardness 60 ±5 Shore A			o 5 mm 6 mm
White smooth rubber lagging (FDA). Oil, fat & grease resistant			x
SPECIAL lagging available on request - e.g. hot vulcanized etc.			x
Single phase motors available on request			x
Electromagnetic brake			x
Min. RL dimensions increases by (mm)			100
Mechanical backstop			x
Modified for vertical mounting			o
Modified for mounting between 5° - ≤90° - e.g. for magnetic separators			o
Insulation class F - Allowable ambient temperature: -25°C/+40°C			Std.
Insulation class H with synthetic oil			x
SPECIAL motors for applications with NO belt contact			x
Low noise drives for noise sensitive areas			x
Parallel shell			x
Thermal protector			Std.
IP66/67 Compact powder coated aluminium terminal box - food grade approved			Std. ≤4.0 kW
IP66/67 Compact stainless steel - AISI 304 or 316 range - terminal box			≤4.0 kW
IP66/67 Larger powder coated aluminium terminal box - food grade approved			Std. ≥5.5 kW
Straight or elbow connector with flying lead			≤4.0 kW
Straight connector with flying lead - Stainless steel - AISI 304 range -			≤4.0 kW
Shaft sealing system - degree of protection IP66/67 (EN60034-5)			Std.
Screened cables - a MUST together with Frequency Converters			x
2 speed motors			x
Euro wide range voltage (3x220-240V / 380-415V 50 Hz) with +/-10% tolerance - DIN IEC 38 or (3x380-400V / 660-690V 50 Hz)			Std.
Special voltages - 50 and/or 60 Hz Please specify!			x
Dual voltage - delta/star - connection possibility!			Std.
CSA approved motors - available on request only!			x

x = Optional extra's

o = An option with certain limitations. Please refer to Technical precautions pages 76-86!

Std. = Fitted as standard



Motorized Pulley 220M & 220H, Ø 216 mm

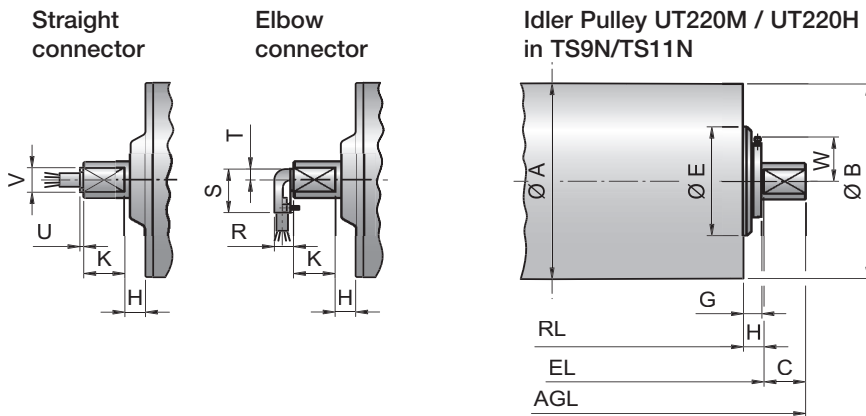
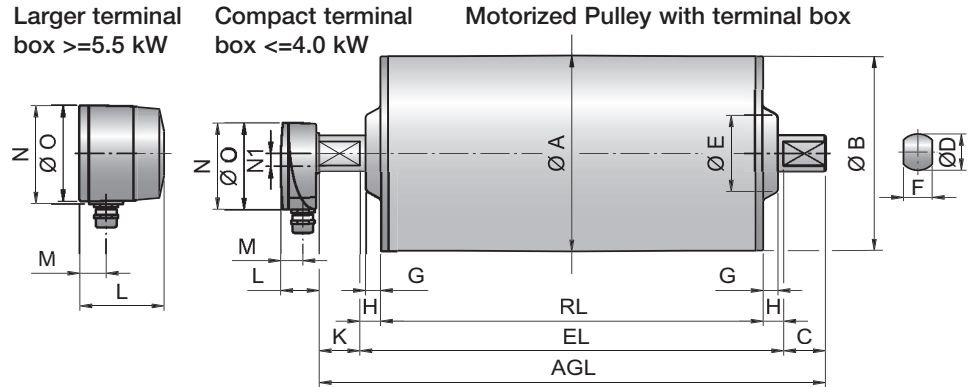

Type	Motorized Pulley or Idler Pulley (UT)											Compact terminal box <4.0 kW				Larger terminal box >5.5 kW				Straight connector <4.0 kW		Elbow connector <4.0 kW		
	A	B	C	D	E	F	G	G TS9/11	H	K	W	L	M	N	N1	L	M	N	O	U	V	R	S	T
mm	mm	mm	mm	mm	mm	mm	mm	mm	mm	mm	mm	mm	mm	mm	mm	mm	mm	mm	mm	mm	mm	mm	mm	
220M & 220H	216	214.5	43.5	40	100	30	15.5	19.5	21.5	41.5	-	41	24	95	14	87	27	107	105	4	27	20	48	12
UT220M & UT220H	216	214.5	43.5	40	100	30	15.5	19.5	21.5	-	52	→ Idler Pulley shown in TS9N/TS11N version with re-greasable seals												

Mounting brackets KL41 & KL41-HD

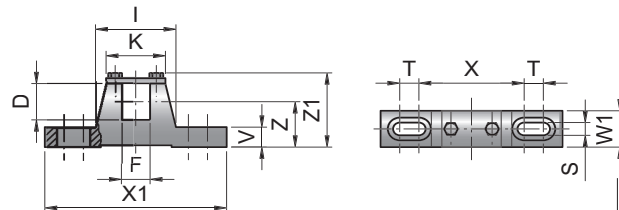

Motorized Pulleys Type	Material	Bracket description	Dimensions													Weight kg
			D	F	I	K	S	T	V	W1	X	X1	Z	Z1		
mm	mm	mm	mm	mm	mm	mm	mm	mm	mm	mm	mm	mm	mm	mm	mm	mm
220M & 220H	Spheroidal cast iron	KL41	40	30	84	62	14	20	22	40	110	190	50	83	1.9	
	Steel	KL41-HD	40	30	84	62	14	20	22	40	110	190	50	83	2.1	



Motorized Pulley 220M & 220H, Ø 216 mm

50 Hz

Power kW/HP	Motor		Nominal belt speed at Full Load 50Hz m/sec	Torque Nm	Belt Pull N	Max. Radial Load T1+T2 N	Special min. RL	Type	Weight in kg for STANDARD width										Type of Bracket	
	No. of Poles	Gear stages							Dimension RL in mm (RL >2000 mm available on request)											
									400	450	500	550	600	650	700	750	800	per 50 mm up to 2000		
0.37/ 0.50	8	3	0.13	291	2707	25000	450	220H											3 kg	KL41-HD
			0.16	236	2195															
	2	8	2	0.20	190	1767	11500	400	220M	48	51	54	57	60	63	66	69	72	3 kg	KL41
				0.25	152	1414														
				0.32	118	1098														
				0.40	95	884														
				0.50	76	707														
				0.63	60	558														
0.80	47	437																		
1.00	38	353																		
1.25	30	279																		
0.55/ 0.75	8	3	0.13	432	4019	25000	500	220H											3 kg	KL41-HD
			0.16	351	3265															
	2	8	2	0.20	282	2623	11500	450	220M	55	58	61	64	67	70	73	76	3 kg	KL41	
				0.25	226	2102														
				0.32	176	1637														
				0.40	141	1312														
				0.50	113	1051														
				0.63	89	828														
0.80	70	651																		
1.00	56	521																		
1.25	45	419																		
0.75/ 1.00	8	3	0.13	592	5510	25000	500	220H											3 kg	KL41-HD
			0.16	481	4476															
	2	8	2	0.20	385	3581	11500	450	220M	55	58	61	64	67	70	73	76	3 kg	KL41	
				0.25	307	2856														
				0.32	239	2223														
				0.40	191	1777														
				0.50	153	1423														
				0.63	122	1135														
0.80	96	893																		
1.00	77	716																		
1.25	62	577																		
1.10/ 1.50	6	3	0.16	705	6558	25000	500	220H											3 kg	KL41-HD
			0.20	564	5246															
	4	4	0.25	452	4205	11500	450	220M	61	64	67	70	73	76	79	82	3 kg	KL41-HD		
			0.32	353	3284															
	2	4	2	0.40	282	2623	11500	400	220M	46	49	52	55	58	61	64	67	70	3 kg	KL41
				0.50	226	2102														
				0.63	178	1656														
				0.80	141	1312														
1.00				112	1042															
1.25				90	837															
1.60	70	651																		
2.00	56	521																		
2.50	45	419																		

Idler Pulley		11500	400	UT220M	25	27	29	31	33	35	37	39	41	2 kg	KL41
		25000	400	UT220H			31	33	35	37	39	41	43	2 kg	KL41-HD



Motorized Pulley 220M & 220H, Ø 216 mm

50 Hz

Motor			Nominal belt speed at Full Load 50Hz m/sec	Torque Nm	Belt Pull N	Max. Radial Load T1+T2 N	Special min. RL	Type	Weight in kg for STANDARD width										Type of Bracket	
Power kW/HP	No. of Poles	Gear stages							Dimension RL in mm (RL >2000 mm available on request)											
									400	450	500	550	600	650	700	750	800	per 50 mm up to 2000		
1.50/ 2.00	4	3	0.25	616	5730	25000	450	220H		61	65	68	71	74	77	80	83	3 kg	KL41-HD	
			0.32	481	4476															
	2	2	2	0.40	385	3581	11500	400	220M	48	51	54	57	60	63	66	69	72	3 kg	KL41
				0.50	307	2856														
				0.63	243	2260														
				0.80	191	1777														
				1.00	153	1423														
				1.25	123	1144														
1.60	96	893																		
2.00	77	716																		
2.50	62	572																		
2.20/ 3.00	4	3	0.32	705	6558	25000	500	220H			68	72	75	78	81	84	87	3 kg	KL41-HD	
			0.40	564	5246															
	2	2	2	0.50	451	4195	11500	450	220M	55	58	61	64	67	70	73	76	3 kg	KL41	
				0.63	358	3330														
				0.80	282	2623														
				1.00	226	2102														
				1.25	180	1674														
				1.60	140	1302														
2.00	115	1070																		
2.50	90	837																		
3.00/ 4.00	4	3	0.50	616	5730	25000	550	220H				74	77	80	83	86	89	3 kg	KL41-HD	
			0.63	481	4476															
	2	2	2	0.80	385	3581	11500	500	220M	60	63	66	69	72	75	78	3 kg	KL41		
				1.00	307	2856														
				1.25	245	2279														
				1.60	192	1786														
				2.00	154	1433														
				2.50	123	1144														
4.00/ 5.50	2	3	0.63	649	6037	25000	550	220H				74	77	80	83	86	89	3 kg	KL41-HD	
			0.80	511	4754															
	2	2	2	1.00	409	3805	11500	500	220M	60	63	66	69	72	75	78	3 kg	KL41		
				1.25	327	3042														
1.60	255	2372																		
2.00	204	1898																		
2.50	163	1516																		
5.50/ 7.50	2	3	0.80	702	6530	25000	550	220H				74	77	80	83	86	89	3 kg	KL41-HD	
			1.00	562	5228															
			1.25	450	4186															
			1.60	351	3265															
			2.00	281	2614															
2.50	225	2093																		

Idler Pulley		11500	400	UT220M	25	27	29	31	33	35	37	39	41	2 kg	KL41
		25000	400	UT220H			31	33	35	37	39	41	43	2 kg	KL41-HD



Motorized Pulley 220M, Ø 216 mm

Spare parts list and sectional drawings

Pos.	Description	Pos.	Description	Pos.	Description
1	Shell	24	2 dust lip seals at each side	70	Toothed washer
2	End housing with geared rim	24	Double lip seal at each side for labyrinth option	78	Gasket
3	End housing	25	O-ring	79	Holding clip or plastic tie
8	Geared rim	26	Bearing	85.1	Intermediate flange for brake assembly
9	Rotor pinion	27	Bearing	91	Electromagnetic brake
10	Input wheel	28	Bearing	93	Retaining ring
11	Output pinion	29	Bearing (Backstop solution: One-way-bearing)	95	Straight connector
12	Gear box	30	Bearing	96	Elbow connector
13	Front shaft	31	Bearing	101	Key
14	Rear shaft	39	Hexagon socket screw	104	Distance washer
15	Stator complete	40	Hexagon socket screw	120	Labyrinth cover
15.1	Rotor	41	Hexagon socket screw	121	Set screw
16	Terminal box complete	52	Magnetic oil plug	122	O-ring
17	Nipple	53	Distance washer	123	Grease nipple
20	Cover	53.1	Compression nipple	124	Distance washer
20.1	Cover with labyrinth groove	59	Countersunk head screw	143	O-ring
23	Rear flange	66	Waved spring washer	146	Special shaped compression washer
23.1	rear flange for backstop	68	Key	200	Rubber seal
23.2	Rear flange for electromagnetic Brake				

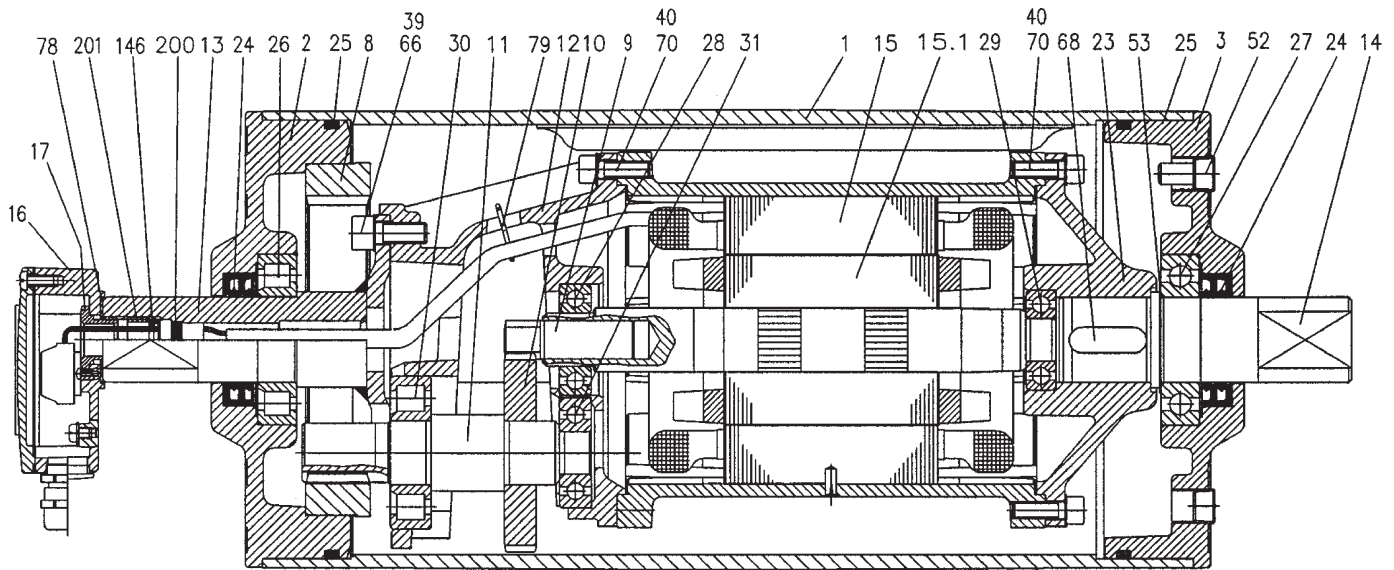



Motorized Pulley 220H, Ø 216 mm

Spare parts list and sectional drawings

Pos.	Description	Pos.	Description	Pos.	Description
1	Shell	23.1	Rear flange for backstop	93	Retaining ring
2	End housing with geared rim	23.3	Rear flange for electromagnetic brake	95	Straight connector
3	End housing	24	2 Dust lip seals each side	96	Elbow connector
8	Geared rim	24	1 double lip seal at labyrinth option	101	Key
9	Rotor pinion	25	O-ring	104	Distance washer
10	Input wheel	26	Bearing	120	Labyrinth cover
11	Output pinion	27	Bearing	121	Set screw
12	Gear box	28	Bearing	122	O-ring
13	Front shaft	29	Bearing (Backstop solution: One-way-bearing)	123	Grease nipple
14	Rear shaft	30	Bearing	124	Distance washer
15	Stator complete	31	Bearing	143	O-ring
15.1	Rotor	39	Hexagon socket screw	146	Special shaped compression washer
16	Terminal box complete	40	Hexagon socket screw	180	Intermediate shaft
17	Nipple	41	Hexagon socket screw	181	Intermediate pinion
20	Cover	52	Magnetic oil plug	182	Distance washer
20.1	Cover with labyrinth groove	53	Distance washer	184	Roller bearing
23	Rear flange	53.1	Compression nipple	185	Roller bearing
		59	Countersunk head screw	186	Key
		66	Waved spring washer	187	Key
		68	Key	188	Spring washer
		70	Toothed washer	190	Spring washer
		78	Gasket	191	Spring washer
		79	Holding clip or plastic tie	194	Set crew
		85.1	Intermediate flange for brake assembly	196	Key
		91	Electromagnetic brake	197	Spring washer
				198	Distance washer
				200	Rubber seal

Intermediate Shaft

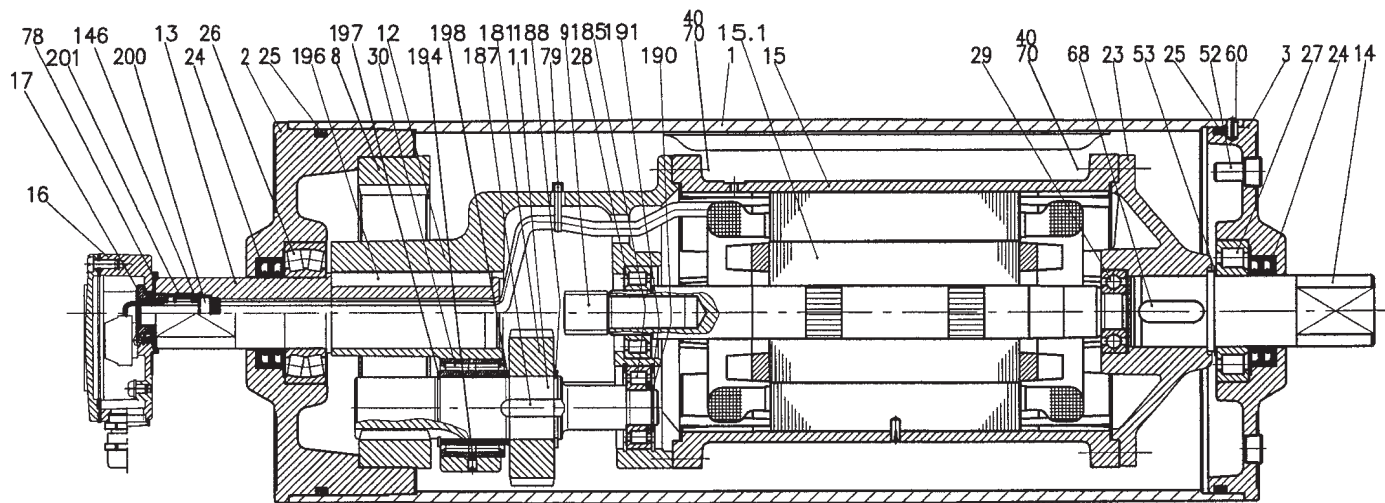
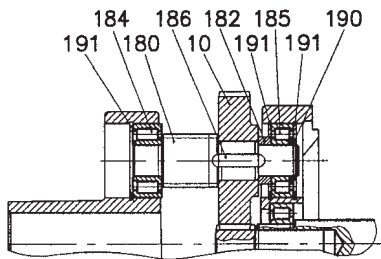



Motorized Pulley 220M & 220H, Ø 216 mm

Sectional drawings

Straight Connector

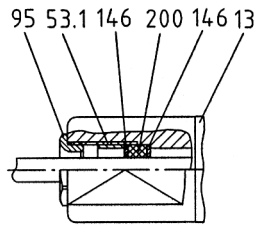

Elbow Connector

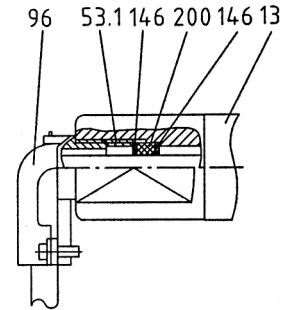

Short Version

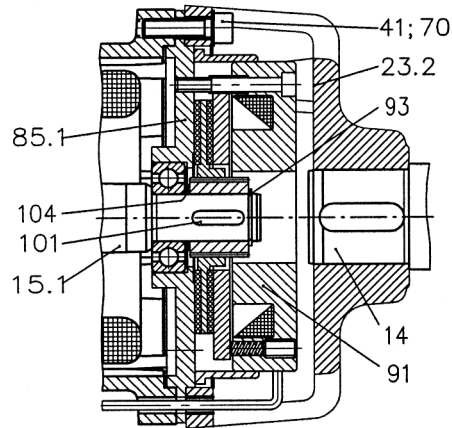

Labyrinth Option - Mild Steel

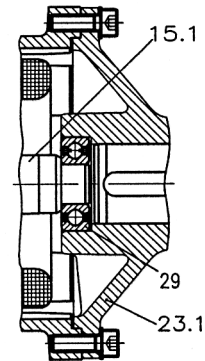

Short Version

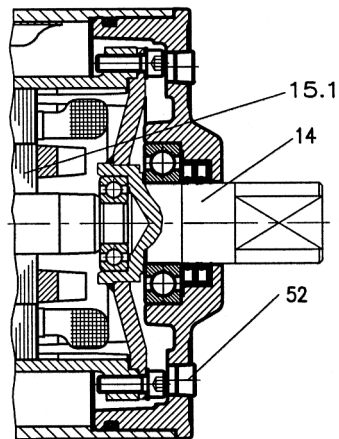

Labyrinth Option - Mild Steel

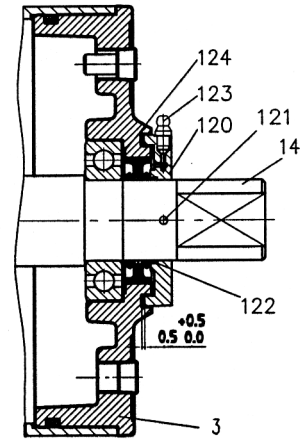



Motorized Pulley 220M & 220H, Ø 216 mm

Sectional drawings

220M & 220H
Stainless steel option TS10N & TS12N

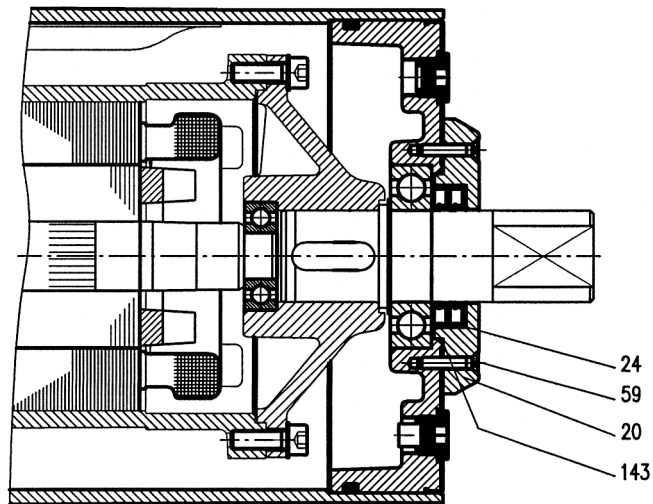

220M & 220H
Stainless steel option TS9N & TS11N

