

## Motorized Pulleys





# Rulmeca – Moving ahead.

*Since its foundation in 1962, the Rulmeca Group, headquartered in Bergamo (Almé), Italy, has grown to become one of the world's leading manufacturers of premium components for material handling. We strongly believe in our positioning as a component supplier and have successfully remained faithful to our mission for more than 50 years. Our reliability as a partner has made Rulmeca one of the most trusted brands in the industry.*

*As a family-owned business, a long-term perspective and responsible action form the basis of Rulmeca Group's economic success. The unique combination of tradition and innovation, of quality and service is our key success factor. This is also seen in our consistent environmental and social responsibility throughout the value chain. More than 1200 employees in twenty-two production and sales companies all around the globe serve Rulmeca clients in 85 countries.*

*Along with our products, which help to handle and move bulk materials and unit loads all over the globe, the Rulmeca Group is also moving ahead. Building on our experience supplying to OEM and end users in Italy, one of Europe's key markets for unit handling applications, we have developed a comprehensive range of components for internal logistics: made by Rulmeca. Our aim? To remain the preferred supplier and trusted partner for our customers who produce and engineer machinery, equipment and systems for unit handling applications.*

*We have something important to offer to our customers.*

*Rulmeca's international presence allows us to access the most efficient sources of procurement, thus boosting the competitiveness of our offering. At the same time our extensive network of affiliated companies and business partners allows us to always be in close contact with our customers. As a vertically integrated manufacturer, we have the flexibility to respond to individual needs whenever they arise.*

*Today the Rulmeca Group's global business encompasses three product brands: Rulmeca, Precismeca and Melco.*

*They are part of one Group, they share a common philosophy, but each has its own character and operates according to the specific needs of its markets and its customers. Following this strategy, Rulmeca Group has grown in recent decades to become the world's largest producer of belt conveyor rollers/idlers and motorized pulleys in the bulk handling industry.*

*We don't only sell products, we find solutions. Our research departments are equipped with dedicated test facilities, where our products are thoroughly examined under extreme conditions. We are committed to the development of new products and the continuous improvement of our current range, often considered among the best in the market. Components provided by the Rulmeca Group improve the performance, safety and reliability of the systems, equipment and machines produced and utilized by our customers.*

*With the benefit of these assets and this strategic focus, the Rulmeca Group offers a portfolio of state-of-the-art components for a vast array of industries and applications handling both bulk materials and unit loads.*

*Our new range of Rulmeca unit handling components comprises rollers, motorized pulleys, 24V drive rollers and controls, as well as modules for dynamic storage. This range of products has been developed for demanding applications such as airport logistics, postal and parcel handling, and logistics applications in manufacturing, distribution centers, food and beverage processing and warehousing.*

*For us, this catalog is an important milestone. And we will keep on moving ahead. Please stay tuned.*

*Kind regards from The Rulmeca Team*

*PS: Feel free to contact your local Rulmeca Company - [www.rulmecacorp.com](http://www.rulmecacorp.com).*

*We look forward to receiving your feedback and comments.*



# Contents

Title	Page
<b>Rulmeca Motorized Pulleys: a new name with deep roots</b>	<b>6</b>
<b>Features and Benefits of Rulmeca Motorized Pulleys</b>	<b>7</b>
<b>General Description &amp; Product Portfolio</b>	<b>8</b>
<b>Ordering Information</b>	<b>9</b>
<b>Application Worksheet</b>	<b>10</b>
<b>Power Calculation for Unit Handling</b>	<b>11</b>
<b>Motorized Pulley 80LP</b> Ø 3.37 in, 0.08 HP – 0.16 HP, with planetary gearbox in polymer	<b>12</b>
<b>Motorized Pulley 80LS</b> Ø 3.21 in, 0.03 HP – 0.16 HP, with helical steel gearbox	<b>18</b>
<b>Motorized Pulley 113LP</b> Ø 4.47 in, 0.08 HP – 0.73 HP, with planetary gearbox in polymer or polymer/steel	<b>28</b>
<b>Motorized Pulley 113LS</b> Ø 4.53 in, 0.05 HP – 0.73 HP, with helical steel gearbox	<b>34</b>
<b>Motorized Pulley 138LS</b> Ø 5.45 in, 0.13 HP – 1.3 HP, with helical steel gearbox	<b>44</b>
<b>Motorized Pulley 165LS</b> Ø 6.50 in, 0.15 HP – 3.0 HP, with helical steel gearbox	<b>54</b>

Title	Page
<b>Optional Extras &amp; Accessories</b>	<b>64</b>
<b>Mounting Brackets for Motorized Pulley and Idler</b>	<b>65</b>
<b>Lagging for Standard Conveyor Belts</b> Smooth or Grooved Lagging	<b>66</b>
<b>Profiled Shells and Lagging for Positive Drive Belts</b> Custom-made Profiled Shells & Lagging	<b>68</b>
<b>Mechanical Backstops</b>	<b>71</b>
<b>Electromagnetic Brakes and Rectifiers</b>	<b>72</b>
<b>Encoders</b>	<b>75</b>
<b>Power Cords</b>	<b>79</b>
<b>Environmental Conditions</b>	<b>81</b>
<b>Technical Precautions for Design, Installation, &amp; Maintenance</b>	<b>84</b>
<b>Shaft Seals and End Housings</b>	<b>91</b>
<b>Oil Quantities and Oil Types</b>	<b>92</b>
<b>Connection Diagrams</b>	<b>94</b>



## Rulmeca Motorized Pulleys: a new name with deep roots

The Rulmeca Motorized Pulleys presented in this catalog have a long history, beginning in the 1950's, when the product was developed in Germany and Denmark.

In 2003, Rulli Rulmeca S.p.A. purchased the production facility in Aschersleben, Germany, where Motorized Pulleys have been developed and produced for more than 60 years.

In 2003, Rulmeca Corporation was founded in Wilmington, NC to sell Motorized Pulleys and provide "local assembly" and aftermarket service to customers in the Americas.

In 2013 Rulmeca Holding S.p.A. purchased a production facility in Dzierzoniow, Poland, where Motorized Pulleys have been developed and produced since the 1990's.

Today these facilities continue the long tradition for quality and reliability under the Rulmeca brand.

Thanks to this long history and a skilled and dedicated staff, Rulmeca is a very experienced and reliable manufacturer of Motorized Pulleys, offering the world's largest product range.

[www.rulmecacorp.com](http://www.rulmecacorp.com)



# Features and Benefits of Rulmeca Motorized Pulleys



## Improves Plant Hygiene

Thanks to its flat, smooth, stainless steel surface and hermetically-sealed design, the Rulmeca drum motor is easy to clean. The Rulmeca drive reduces the risk of contamination in food processing environments.

## Resists Harsh Operating Conditions

The Rulmeca IP69 sealing system protects the drum motor from the most aggressive operating conditions. Neither the presence of water, chemicals, grease, and oil nor high pressure wash-down procedures are problems for the drive.

## Improves Personnel Safety

The Rulmeca drum motor protects plant personnel from pinch points as well as slip, trip, and fall hazards because it encloses all moving mechanical parts within a pulley shell. The drive eliminates the need for expanded metal guarding around rotating shafts, external gearboxes, motors, and cooling fans.

## Reduces Maintenance Expense

Since the Rulmeca drum motor does not use external bearings which require greasing and inspection, but rather encloses all mechanical parts within an oil-filled shell, it reduces maintenance requirements to a fraction of what exposed drive systems require.

## Improves Conveyor Reliability

Since 1952, the Rulmeca drum motor has been a reliable conveyor drive. The hermetic seals and continuous oil bath of all bearings and gears insure that the drive provides consistent "up time" in spite of 24/7 operating conditions.

## Increases Efficiency

Rulmeca drum motors require less than 90% of the electrical power of exposed drive systems when compared with motor/reducer/chain & sprocket or motor/reducer/V-belt drive configurations.

## Saves Space

The Rulmeca drum motor encloses its motor, gearbox, and bearings within a hermetically-sealed, oil-filled pulley shell, making it a very compact and lightweight conveyor drive system. This is a big advantage to operators and manufacturers of package handling and processing equipment.

## Makes Installation Easier

Since the Rulmeca drum motor is compact, lightweight, and pre-aligned, installation is quick and easy. Setting the drive only requires four bolts and electrical termination. Installation time is usually 1 to 2 hours. Heavy external gearboxes and motor frames, as well as guarding around rotating shafts, are eliminated.



## General Description & Product Portfolio

The Rulmeca Motorized Pulley was first produced in 1953 specifically for use on conveyor belt applications.

The objective was to produce a compact, hermetically-sealed, highly efficient conveyor drive that would be unaffected by dust, water, oil, grease or other harmful substances. A Motorized Pulley was to be simple to install and require very little maintenance.

The Rulmeca Motorized Pulley achieved this objective and today is considered to be one of the most reliable, effective and safe conveyor drive systems available throughout the world.

The Rulmeca Motorized Pulley is a highly efficient geared motor drive, which is hermetically-sealed within a cylindrical steel shell.

The shell, which is normally crowned to ensure belt tracking, is fitted with bearing housings incorporating precision bearings and double lip oil seals and rotates on a pair of fixed shafts.

The motor stator is fixed to the shafts and the motor winding cables pass through one of the shafts, eliminating the need for slip rings and brushes.

The squirrel cage induction motor, manufactured in steel laminate, is machined concentric to high tolerances and designed to give 200% starting torque for 3 phase versions.

The rotor pinion is coupled directly to the gearbox.

The gearbox transmits torque to the shell through a geared rim and allows very little frictional torque loss.

The Motorized Pulley is filled with oil, which acts as a lubricant and coolant. Heat is dissipated through the shell and conveyor belt.

All vital parts are CNC machined.

The Rulmeca Motorized Pulley is supplied as standard with:

- Machined steel (type LS) and aluminum (type LP) crowned shell.
- Electrical motor manufactured in accordance with IEC 34-1 (EN60034-1), (VDE0530).
- Class F insulation according to IEC 34-1 (EN60034-1), (VDE0530).
- Most international voltages.
- Standard voltages supplied with +/- 10% tolerance in accordance with IEC 38.
- Factory oil-filled and tested.

•Degree of protection IP66 (EN60034-5). Rulmeca Motorized Pulleys are manufactured according to the Council Directives of the European Communities.

The CE-marking is according to Directive 73/23/EEC, relating to electrical equipment, and according to Directive 89/336EEC, relating to electrical magnetic compatibility and amendments.

Model		80LP	80LS	113LP	113LS	138LS	165LS
<b>Diameter [in]</b>		3.37	3.21	4.47	4.53	5.45	6.50
<b>Power [HP]</b>	from	0.08	0.05	0.08	0.05	0.13	0.15
	to	0.16	0.21	0.50	0.75	1.33	3.00
<b>Belt Pull [lbs]</b>	from	24	22	16	33	60	63
	to	112	137	202	339	700	990
<b>Belt Speed [fpm]</b>	from	14	26	6	12	10	12
	to	150	220	240	384	480	768
<b>Roller Length RL [in]</b>	from	9.96	7.87	10.08	9.84	11.81	13.78
	to	35.43	47.24	47.24	55.12	72.83	78.74





# Ordering\* Information: Rulmeca Drum Motors

Email: sales-us@rulmeca.com

Fax: 910-794-9296

Contact Person \_\_\_\_\_ Date \_\_\_\_\_ Ref# \_\_\_\_\_

Company \_\_\_\_\_

Address \_\_\_\_\_

Phone \_\_\_\_\_ Fax \_\_\_\_\_ Email \_\_\_\_\_

Diameter (in)		Roller Length (in)		Belt Speed (fpm)		Lagging Material		Type of Mounting Brackets	
<input type="checkbox"/>	3.15	<input type="checkbox"/>	11.81	<input type="checkbox"/>	10	<input type="checkbox"/>	Blue rubber	<input type="checkbox"/>	aluminum
<input type="checkbox"/>	4.50	<input type="checkbox"/>	12.60	<input type="checkbox"/>	12	<input type="checkbox"/>	White rubber	<input type="checkbox"/>	stainless steel
<input type="checkbox"/>	5.45	<input type="checkbox"/>	13.78	<input type="checkbox"/>	14	<input type="checkbox"/>	Black rubber	<input type="checkbox"/>	cast iron
<input type="checkbox"/>	6.49	<input type="checkbox"/>	15.75	<input type="checkbox"/>	16	<input type="checkbox"/>	None	<b>Type of Holdback</b>	
<b>Power (HP)</b>		<input type="checkbox"/>	17.72	<input type="checkbox"/>	18	<b>Lagging Profile</b>		<input type="checkbox"/>	mech. backstop, clockwise
<input type="checkbox"/>	0.03	<input type="checkbox"/>	19.69	<input type="checkbox"/>	20	<input type="checkbox"/>	Smooth	<input type="checkbox"/>	mech. backstop, counterclockwise
<input type="checkbox"/>	0.05	<input type="checkbox"/>	21.65	<input type="checkbox"/>	24	<input type="checkbox"/>	Profiled	<input type="checkbox"/>	internal brake
<input type="checkbox"/>	0.08	<input type="checkbox"/>	23.62	<input type="checkbox"/>	26	<b>Lagging Thickness</b>		<b>Type of Seals</b>	
<input type="checkbox"/>	0.09	<input type="checkbox"/>	25.59	<input type="checkbox"/>	30	<input type="checkbox"/>	1/8 inch	<input type="checkbox"/>	standard
<input type="checkbox"/>	0.10	<input type="checkbox"/>	27.56	<input type="checkbox"/>	38	<input type="checkbox"/>	1/4 inch	<input type="checkbox"/>	IP69
<input type="checkbox"/>	0.11	<input type="checkbox"/>	29.53	<input type="checkbox"/>	48	<input type="checkbox"/>	1/2 inch	<input type="checkbox"/>	regreasable
<input type="checkbox"/>	0.12	<input type="checkbox"/>	31.50	<input type="checkbox"/>	60	<b>Termination (select one)</b>		<b>Material &amp; Surface Finish</b>	
<input type="checkbox"/>	0.13	<input type="checkbox"/>	33.46	<input type="checkbox"/>	76	<input type="checkbox"/>	compact box, AL	<input type="checkbox"/>	stan. mild steel & aluminum
<input type="checkbox"/>	0.15	<input type="checkbox"/>	35.43	<input type="checkbox"/>	96	<input type="checkbox"/>	compact box, SS	<input type="checkbox"/>	total stainless steel
<input type="checkbox"/>	0.16	<input type="checkbox"/>	37.40	<input type="checkbox"/>	120	<input type="checkbox"/>	power cord, elbow connector	<input type="checkbox"/>	semi-rust free
<input type="checkbox"/>	0.20	<input type="checkbox"/>	39.37	<input type="checkbox"/>	150	<input type="checkbox"/>	power cord, straight connector	<b>Other Special Options</b>	
<input type="checkbox"/>	0.24	<input type="checkbox"/>	41.34	<input type="checkbox"/>	192	<b>Power cord (if applicable)</b>		<input type="checkbox"/>	vertical shaft
<input type="checkbox"/>	0.25	<input type="checkbox"/>	43.31	<input type="checkbox"/>	240	<input type="checkbox"/>	10 ft, standard insulation	<input type="checkbox"/>	inclined shaft
<input type="checkbox"/>	0.33	<input type="checkbox"/>	45.28	<input type="checkbox"/>	300	<input type="checkbox"/>	10 ft, screened	<input type="checkbox"/>	encoder (SKF)
<input type="checkbox"/>	0.40	<input type="checkbox"/>	47.24	<input type="checkbox"/>	384	<b>Type of Oil</b>		<input type="checkbox"/>	encoder (RLS)
<input type="checkbox"/>	0.50	<input type="checkbox"/>	49.21	<input type="checkbox"/>	480	<input type="checkbox"/>	mineral	<input type="checkbox"/>	low noise
<input type="checkbox"/>	0.75	<input type="checkbox"/>	51.18	<input type="checkbox"/>	600	<input type="checkbox"/>	synthetic	<input type="checkbox"/>	special certification (please specify)
<input type="checkbox"/>	1.00	<input type="checkbox"/>	53.15	<input type="checkbox"/>	768	<input type="checkbox"/>	food grade	<input type="checkbox"/>	special shell (attach drawing)
<input type="checkbox"/>	1.33	<input type="checkbox"/>	55.12	<b>Voltage</b>		<b>Motor Insulation</b>		<input type="checkbox"/>	special end housing (attach drawing)
<input type="checkbox"/>	1.50	<input type="checkbox"/>	57.09	<input type="checkbox"/>	115v	<input type="checkbox"/>	class F	<input type="checkbox"/>	special shaft (attach drawing)
<input type="checkbox"/>	2.00	<input type="checkbox"/>	59.06	<input type="checkbox"/>	208v	<input type="checkbox"/>	class H	<input type="checkbox"/>	special key requirements (attach drawing)
<input type="checkbox"/>	3.00	<input type="checkbox"/>	61.02	<input type="checkbox"/>	230v	<b>Type of Crown</b>		<b>Center Groove Dimensions (if applicable)</b>	
		<input type="checkbox"/>	62.99	<input type="checkbox"/>	230v	<input type="checkbox"/>	center crown	Top _____ (in.)	
		<input type="checkbox"/>	64.96	<input type="checkbox"/>	380v	<input type="checkbox"/>	trapezoidal crown	Bottom _____ (in.)	
		<input type="checkbox"/>	66.93	<input type="checkbox"/>	460v	<input type="checkbox"/>	no crown	Depth _____ (in.)	
		<input type="checkbox"/>	68.90	<input type="checkbox"/>	575v				
		<input type="checkbox"/>	70.87	<b>Phase &amp; Frequency</b>					
		<input type="checkbox"/>	72.83	<input type="checkbox"/>	3ph/60Hz				
		<input type="checkbox"/>	74.80	<input type="checkbox"/>	3ph/50Hz				
		<input type="checkbox"/>	76.77	<input type="checkbox"/>	1ph/60Hz				
		<input type="checkbox"/>	78.74	<input type="checkbox"/>	1ph/50Hz				
		<input type="checkbox"/>	Other	<input type="checkbox"/>	Other				

Quantity: \_\_\_\_\_ Drum Motors

Special Comments: \_\_\_\_\_

\* Note: This form displays all powers, speeds, and options available in small drum motors from Rulmeca. Some combinations are unavailable (e.g. 3 HP is not available in 4.5 inch diameter).



# Application Worksheet: Rulmeca Drum Motors

Email: sales-us@rulmeca.com  
Fax: 910-794-9296

Contact Person \_\_\_\_\_ Date \_\_\_\_\_ Ref# \_\_\_\_\_  
Company \_\_\_\_\_  
Address \_\_\_\_\_  
Phone \_\_\_\_\_ Fax \_\_\_\_\_ Email \_\_\_\_\_

Standard Loading Conditions:	
Conveyor Length (ft)	_____
Conveyor Lift Height (ft)	_____
Weight of Conveyed Product (lbs/ft of conveyor)	_____
Weight of Conveyor Belt (lbs/ft of conveyor)	_____
Conveyor Belt Speed (feet per minute)	_____
Width of Conveyor Belt (in)	_____
Operating Conditions:	
Duty Cycle (Start/stops per hour)	_____
Hours of Operation (hrs/day)	_____
Days of Operation (days/week)	_____
Is this a reversing conveyor?	_____
Temperature of Conveyed Product (°F)	_____
Minimum Ambient Temperature (°F)	_____
Maximum Ambient Temperature (°F)	_____
Slider Bed Friction Without Accumulation (Choose one):	
Frictional Coefficient: bottom of belt to top of steel slider bed	
<input type="checkbox"/>	0.2 for Impregnated Fabric Backing
<input type="checkbox"/>	0.3 for Brushed Backed PVC
<input type="checkbox"/>	0.6 for PVC Backing
<input type="checkbox"/>	0.65 for Rubber Belt
<input type="checkbox"/>	Other (please specify) _____
Roller Conveyor Without Accumulation Load:	
Weight of Rotating Parts (lbs/ft of conveyor)	_____

Accumulation Friction Load (Choose one, if applicable):	
Frictional Coefficient: top of belt to bottom of product	
<u>Cardboard Products</u>	
<input type="checkbox"/>	0.25 for Impregnated Urethane
<input type="checkbox"/>	0.35 for Urethane Cover
<input type="checkbox"/>	0.40 for PVC Cover
<input type="checkbox"/>	0.45 for Rubber Cover
<input type="checkbox"/>	Other (please specify) _____
<u>Plastic Products</u>	
<input type="checkbox"/>	0.25 for Impregnated Urethane
<input type="checkbox"/>	0.35 for Urethane Cover
<input type="checkbox"/>	0.40 for PVC Cover
<input type="checkbox"/>	0.45 for Rubber Cover
<input type="checkbox"/>	Other (please specify) _____
<u>Glass Products</u>	
<input type="checkbox"/>	0.20 for Impregnated Urethane
<input type="checkbox"/>	0.40 for Urethane Cover
<input type="checkbox"/>	0.50 for PVC Cover
<input type="checkbox"/>	0.55 for Rubber Cover
<input type="checkbox"/>	Other (please specify) _____
<u>Steel Products</u>	
<input type="checkbox"/>	0.30 for Impregnated Urethane
<input type="checkbox"/>	0.50 for Urethane Cover
<input type="checkbox"/>	0.60 for PVC Cover
<input type="checkbox"/>	0.65 for Rubber Cover
<input type="checkbox"/>	Other (please specify) _____

Quantity: \_\_\_\_\_ Drum Motors  
Special Comments: \_\_\_\_\_

## Calculation of Required Belt Pull (Force)

$F$	= Belt Pull [lbs] = $F = F_0 + F_1 + F_2 + F_3$ The belt pull for each motorized pulley is given in the tables of the range of standard products. Note that available belt pull varies with nominal belt speed for each power.	
$P_n$	= Belt weight per linear foot	[lb/ft]
$P_{pr}$	= Weight of rotating parts of the belt conveyor per foot length (carrying and return section)	[lb/ft]
$P_{m1}$	= Weight in lbs of the conveyed product on the load section, for each foot of length of the belt conveyor	[lb/ft]
$P_{m2}$	= Weight in lbs of the conveyed product on the return section, for each foot of length of the belt conveyor	[lb/ft]
$C_1$	= Coefficient of friction between product and belt carrying side	
$C_2$	= Coefficient of friction between belt carrying side and slider bed	
$C_3$	= Coefficient of friction between return belt and product	
$C_4$	= Coefficient of friction between return belt side and slider bed	
$L$	= Length of the conveyor in feet	[ft]
$H$	= Height difference in conveyor	[ft]
$F_0$ to $F_3$	= Forces (belt pull) required to move conveyor, as defined below.	[lb]

## Calculation of Required Belt Pull (Force)

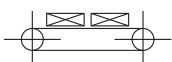
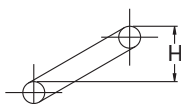
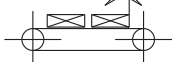
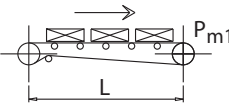
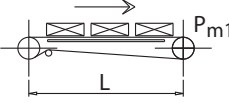
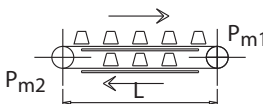
				
	Force without load	Force to convey materials horizontally	Force to convey materials on incline	Accumulation
	$F_0 = 0.04 \cdot L \cdot (2P_n + P_{pr})$	$F_1 = 0.04 \cdot L \cdot P_{m1}$	$F_2 = H \cdot P_{m1}$	$F_3 = L \cdot P_{m1} \cdot C_1$
Roller bed conveyor				
	$F_0 = 1.1 \cdot L \cdot P_n \cdot C_2$	$F_1 = 1.1 \cdot L \cdot P_{m1} \cdot C_2$	$F_2 = H \cdot P_{m1}$	$F_3 = L \cdot P_{m1} \cdot C_1$
Slider bed conveyor				
	$F_0 = L \cdot P_n \cdot (C_2 + C_4)$	$F_1 = L \cdot (P_{m1} \cdot C_2 + P_{m2} \cdot C_4)$	$F_2 = H \cdot (P_{m1} - P_{m2})$	$F_3 = L \cdot (P_{m1} \cdot C_1 + P_{m2} \cdot C_3)$
Double slider bed conveyor				



## Motorized Pulley 80LP

Ø 3.37 in. (80 mm), with planetary gearbox in polymer

### Product description

Due to its strength, reliability, and need for no maintenance, this motorized pulley is used in small conveyors, packaging machines, and simple transfer units.

### Characteristics

- Asynchronous 3 phase or 1 phase AC induction motor
- Integral motor protection
- Planetary gearbox in polymer or polymer / steel combination
- Low noise operation
- Light and distributed weight
- Maintenance free
- Lifetime lubrication
- Reversible operation
- Motorized Pulleys with RL greater than 21.65 inches have reinforced shaft

### Applications

- Small conveyors for light loads, non-continuous use
- Transfer conveyors
- Packaging machines for light loads
- Metal detection, x-ray scanners
- Check stands in supermarkets
- Dry or humid applications

### Technical data

<b>Type of motor</b>	Asynchronous squirrel-cage, IEC 34 (VDE 0530)
<b>Insulation class of motor windings</b>	Class F, IEC 34 (VDE 0530)
<b>Available power supplies*</b>	115v/1ph/60Hz, 230v/1ph/60Hz, 230v/3ph/60Hz, 460v/3ph/60Hz
<b>Seal protection rating</b>	IP66
<b>Thermal protection</b>	Bimetallic contact
<b>Allowable ambient temperature, 3-phase motor</b>	+41°F to + 104°F
<b>Allowable ambient temperature, 1-phase motor</b>	+50° F to +104° F
<b>Max. roller length (RL)</b>	35.91 in

\* Other power supply voltages and frequencies are available.



# Motorized Pulley 80LP

Ø 3.37 in. (80 mm), with planetary gearbox in polymer



## Materials

Component	Version	Aluminum	Steel	Stainless Steel	Brass /Nickel
Shell	Crowned	Std	Opt	Opt	-
	Cylindrical	Opt	Opt	Opt	-
	Special crowns with grooves	Opt	Opt	Opt	-
End housing	Standard	Std	-	Opt	-
Shaft cap	Standard (with straight/90° free position cable)	Std	-	-	-
Electrical termination	Power cord with straight connector	-	-	Opt	Opt
	Power cord with 90° connector	-	-	Opt	Opt
	Power cord with elbow connector	Opt	-	Opt	-

## Options

- Dynamic balancing
- Food grade oil (EU, FDA and USDA)
- Non-horizontal mounting (more than  $\pm 5^\circ$ )
- For special versions, please contact RULMECA

## Power Cord Specifications

- Standard, unshielded, 6 feet long
- Other types & lengths available upon request



# Motorized Pulley 80LP

Ø 3.37 in. (80 mm), with planetary gearbox in polymer

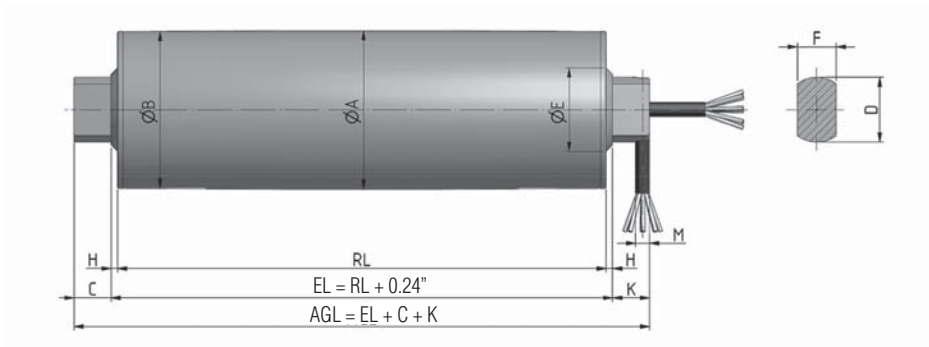

Motorized Pulley Standard Version.

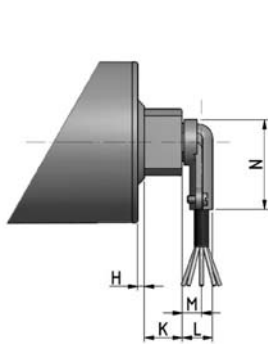

Elbow connector in aluminum.

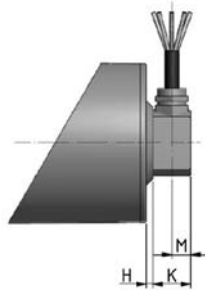

Cable connection 90°.

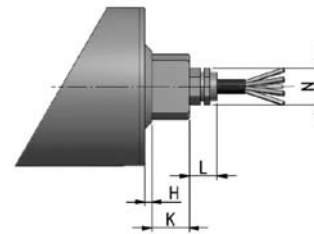

Straight connector.

Type/Option	A in	B in	C in	D in	E in	F in	G in	H in	K in	L in	M in	N in	Q in	T in
<b>Motorized Pulley Standard Version</b>	3.37	3.33	0.79	1.38	1.77	0.83		0.12	0.79		0.31			
<b>Elbow connector in aluminum</b>									0.79	0.71	0.47	1.89		
<b>Cable connection 90°</b>									0.79		0.39			
<b>Straight Connector</b>									0.79	0.59		0.79		

<b>Std. RL shell lengths (in)</b>	11.81	13.78	15.75	17.72	19.69	21.65	23.62	25.6	27.56	29.53	31.5	33.46	35.43
<b>Avg. weight (lbs)</b>	9.5	10.0	10.5	11.0	11.0	11.5	12.0	17.0	17.5	18.0	19.0	20.0	20.5

- Min length: 9.96 in.
- Max length: 35.43 in
- Weights are approximate due to different shell executions and motor powers

# Motorized Pulley 80LP

Ø 3.37 in. (80 mm), with planetary gearbox in polymer



Power & Speed Combinations: 3 phase														
Power HP	Poles	FLA (amps) <sup>1</sup>	No. Gear Stages	Gear Ratio	Nominal belt speed at Full Load 60 Hz fpm <sup>2</sup>	Actual belt speed at Full Load 60 Hz fpm <sup>2</sup>	Belt Pull lbs	Max. Radial Load T1 + T2 lbs <sup>3</sup>	RL in					
0.08	4	0.6/0.4	3	77.1	12	14	112*	450	min 10.59 max 35.43					
				64.4	14	16	112*							
				54.5	18	20	112							
				46.0	24	22	101							
				43.7	26	24	92							
				36.8	30	30	75							
				35.0	35	32	70							
				29.5	38	38	59							
			23.2	48	48	47								
2	14.2	76	78	29	min 9.96 max 35.43									
0.16	4	0.9/0.7	3	29.5	38	38	94*	450	min 11.50 max 35.43					
				23.2	48	48	94							
			2	14.2	76	78	58	49	340	min 10.87 max 35.43				
											12.0	90	92	49
											11.3	96	98	46
											9.5	120	118	38
											7.5	150	155	29

Power & Speed Combinations: 1 phase														
Power HP	Poles	FLA (amps) <sup>1</sup>	No. Gear Stages	Gear Ratio	Nominal belt speed at Full Load 60 Hz fpm <sup>2</sup>	Actual belt speed at Full Load 60 Hz fpm <sup>2</sup>	Belt Pull lbs	Max. Radial Load T1 + T2 lbs <sup>3</sup>	RL in					
0.08	4	0.05	3	77.1	12	14	112*	450	min 11.02 max 35.43					
				64.4	14	16	112*							
				54.5	18	20	112							
				46.0	24	22	101							
				43.7	26	24	92							
				36.8	30	30	75							
				35.0	35	32	70							
				29.5	38	38	59							
			23.2	48	48	47								
2	14.2	76	78	29	min 10.59 max 35.43									
0.1	4	0.07	3	36.8	30	30	90	450	min 11.50 max 35.43					
				35.0	35	32	84							
				29.5	38	38	70							
				23.2	48	48	58							
			2	14.2	76	78	36	31	340	min 10.87 max 35.43				
											12.0	90	92	31
											11.3	96	98	29
											9.5	120	118	24

- 1 FLA = full load amps at 230 volts & 460 volts (in 3 phase) and 230 volts (in 1 phase), respectively.
- 2 Use "Nominal Speed" to specify pulley. "Actual belt speed" is presented (for unlagged pulley) to assist with process design calculations. See "Actual Speed vs Nominal Speed" section in Technical Precautions. Note that actual belt speed increases when lagging is used due to increased pulley diameter.
- 3 Pulley must not be subjected to radial load exceeding "Maximum Radial Load" defined above. See "Belt Tension" section in Technical Precautions.
- \* Note that belt pull is restricted in certain (slow speed) cases. Contact Rulmecca for more information.



# Motorized Pulley 80LP

Ø 3.37 in. (80 mm), with planetary gearbox in polymer

## Spare Parts List and Sectional Drawings

1	Shaft cap (rear)	14	Wavey washer	27	Tywrap
2	Set screw	15	Flat washer	28	O-ring
3	Ball bearing	16	Planet gear (short)	29	Set screw
4	O-ring	17	Circlips	30	Compression seal
5	Oil seal	18	Ball bearing	31	Straight connector
6	Ring gear	19	Stator housing	32	End housing
7	Gear holder	20	Rotor	33	Shell
8	Roll pin	21	Stator	34	Shaft
9	Planet gear (long)	22	Stator housing	35	Rotor journal bearing
10	Planet gear (short)	23	Stator bolt	36	Rotor shaft
11	Sun gear (long)	24	Nut	37	Shaft cap (front)
12	Sun gear (short)	25	Rivet	38	Power cord
13	Gear carrier	26	Dowel pin	39	X-ring

## 80LP Standard:

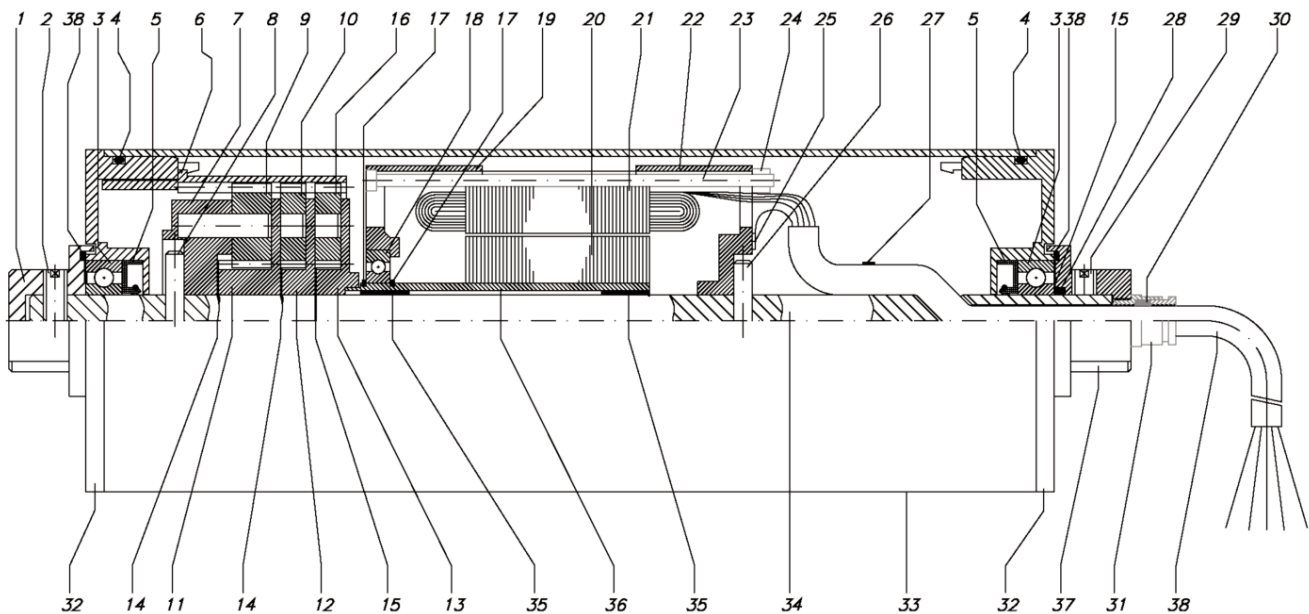







## Motorized Pulley 80LS

Ø 3.21 in. (80 mm), with steel helical gearbox

### Product description

This Motorized Pulley is perfect for high torque applications with limited space or access.

### Characteristics

- Asynchronous 3 phase AC induction motor
- Integral motor protection
- Hardened steel helical gearbox
- Low noise operation
- Reversible operation
- Motorized Pulleys with RL greater than 19.69 inches have reinforced shaft.

### Applications

- Small package handling conveyors with high duty cycle
- Dynamic weighing equipment
- Metal detectors
- Pharmaceutical equipment
- Food processing equipment
- Positive drive and modular belt conveyors
- Dry, humid and wash down applications

### Technical data

<b>Type of Motor</b>	Asynchronous squirrel-cage, IEC 34 (VDE 0530)
<b>Insulation class of motor windings</b>	Class F, IEC 34 (VDE 0530)
<b>Available power supplies*</b>	230v/3ph/60Hz, 460v/3ph/60Hz
<b>Seal protection rating (standard)</b>	P66
<b>Seal protection rating (optional)</b>	IP69
<b>Thermal protection</b>	Bimetallic contact
<b>Allowable ambient temperature, 3-phase motor</b>	+32° F to +104° F
<b>Max. roller length (RL)</b>	39.37 in

\* Other power supply voltages and frequencies are available.



# Motorized Pulley 80LS

Ø 3.21 in. (80 mm), with steel helical gearbox



## Materials

Component	Version	Aluminum	Steel	Stainless steel
<b>Shell</b>	Crowned	-	Std	Opt
	Cylindrical	-	Std	Opt
	Cylindrical with key (for sprockets)	-	Opt	Opt
	Special profiles	-	Opt	Opt
<b>End housing</b>	Standard	Std	-	Opt
<b>Shaft</b>	Standard	-	-	Std
	Cross-drilled and threaded, M6	-	-	Opt
<b>Electrical termination</b>	Power cord with straight ss connector	-	-	Std
	Power cord with elbow ss connector	-	-	Std
	Power cord w/shaft cap & ss elbw connector	-	-	Std

## Options

- Rubber lagging for standard belts
- Profiled lagging for positive drive belts
- Profiled ss shells for positive drive belts
- Mechanical backstop
- Special smooth stainless steel end housings, slotted screw oil plugs, Viton® shaft seals and PTFE deflection seals (option TS8N) for IP69 sealing.
- Electromagnetic brake
- Rectifier
- Encoder
- Food grade oil (EU, FDA and USDA)
- Non-horizontal mounting (more than ± 5°)

## Power Cord Specifications

- Standard, shielded, 10 feet long
- Other types & lengths available upon request



# Motorized Pulley 80LS

Ø 3.21 in. (80 mm), with steel helical gearbox

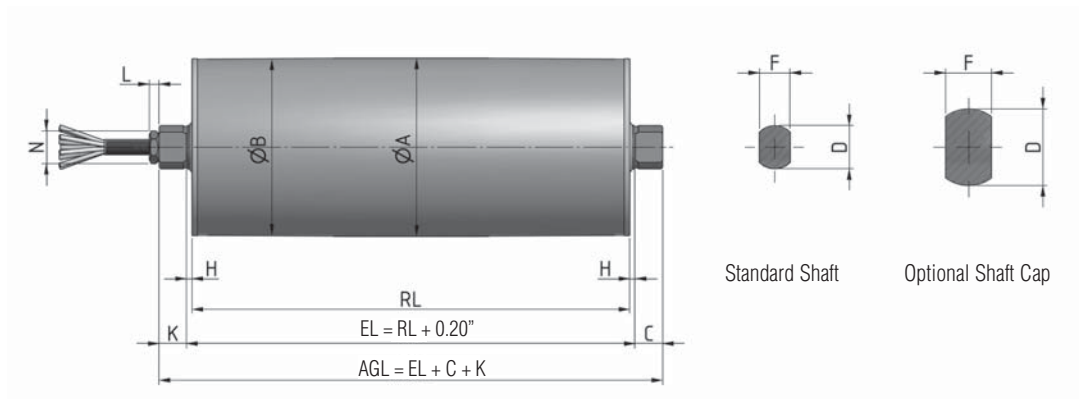

Standard Motorized Pulley with straight stainless steel connector

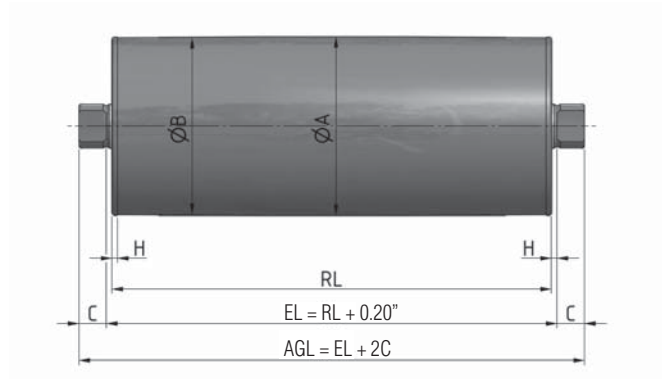

Idler Pulley

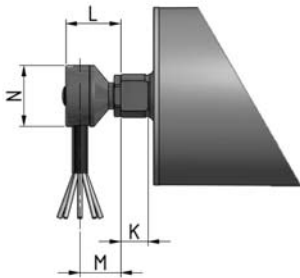

Standard shaft with stainless steel elbow connector

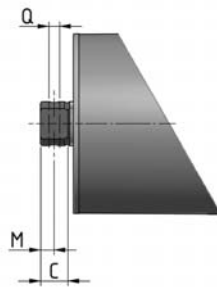

Cross-drilled and threaded shaft.

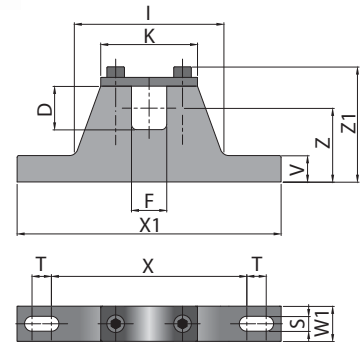

MC = Mounting bracket center-to-center spacing =  $RL + 0.59$ "

Mounting bracket

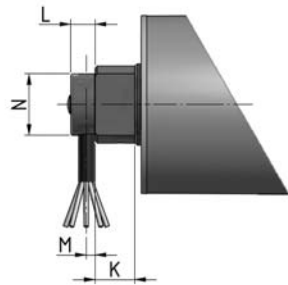

Shaft cap with stainless steel elbow connector

# Motorized Pulley 80LS

Ø 3.21 in. (80 mm), with steel helical gearbox



## Dimensions for Motorized Pulley 80LS

Type/Option	A in	B in	C in	D in	E in	F in	G in	H in	K in	L in	M in	N in	Q in	T in
Standard shaft with ss straight connector	3.21	3.17	0.49	0.67		0.53		0.1	0.49	0.18		0.59		
Standard shaft with ss elbow connector									0.49	0.98	0.73	1.1		
Cross-drilled and threaded shaft			0.49								0.25		M6	
Shaft cap with ss elbow connector				1.38		0.83			0.71	0.43	0.16	1.1		

## Revised Dimensions for options

The following options increase the minimum roller length (RL)

Option	Optional RL min.
Electromagnetic brake	Standard RL min. + 1.97in
Encoder	Standard RL min. + 1.97in

## Dimensions, materials, and weights for Mounting Brackets

Motorized Pulley	Standard Material	Optional Material	D [in]	F [in]	I [in]	K [in]	S [in]	T [in]	V [in]	W1 [in]	X [in]	X1 [in]	Z [in]	Z1 [in]	Thread	Weight [lbs]
80LS	Aluminum	Stainless steel	0.67	0.53	2.24	1.50	0.26	0.35	0.47	0.39	2.83	4.06	1.38	2.17	M6	0.3/0.5

## Standard weights for Motorized Pulley 80LS

Power HP	Poles	Standard weight [lbs] for standard RL [in]													
		7.87	9.84	11.81	13.78	15.75	17.72	19.69	21.65	23.62	25.59	27.56	31.5	35.43	39.37
0.027	8	---	7.5	8.5	9.5	10.5	11.5	12.5	13.5	14.5	15.5	16.5	17.5	18.5	19.5
0.047	4	6.0	7.0	8.0	9.0	10.0	11.0	12.0	13.0	14.0	15.0	16.0	17.0	18.0	19.0
0.09	4	---	7.5	8.5	9.5	10.5	11.5	12.5	13.5	14.5	15.5	16.5	17.5	18.5	19.5
	2	6.0	7.0	8.0	9.0	10.0	11.0	12.0	13.0	14.0	15.0	16.0	17.0	18.0	19.0
0.16	2	---	7.5	8.5	9.5	10.5	11.5	12.5	13.5	14.5	15.5	16.5	17.5	18.5	19.5



# Motorized Pulley 80LS

Ø 3.21 in. (80 mm), with steel helical gearbox

Power & Speed Combinations: 3 phase									
Power HP	Poles (rpm)	FLA (amps) <sup>1</sup>	No. Gear Stages	Gear Ratio	Nominal belt speed at Full Load 60 Hz fpm <sup>2</sup>	Actual belt speed at Full Load 60 Hz fpm <sup>2</sup>	Belt Pull lbs	Max. Radial Load T1 + T2 lbs <sup>3</sup>	RL in
0.05	4 (1670)	0.52/0.27	3	53.89	26	26	57	810	min 7.87 max 47.24
				37.78	38	38	40		
				30.88	48	45	33		
			2	21.23	72	66	22	600	
0.09	4 (1630)	0.79/0.40	3	53.89	26	26	116	810	min 9.84 max 47.24
				37.78	38	35	82		
				30.88	48	45	67		
			2	21.23	60	64	46	600	
				14.88	90	92	32		
				12.16	120	111	26		
	2 (3180)	0.60/0.31	3	53.89	52	50	60	600	min 7.87 max 47.24
				37.78	72	71	42		
30.88				90	85	34			
2			21.23	120	125	24	475		
0.16	2 (3230)	0.78/0.35	3	53.89	52	50	101	600	min 9.84 max 47.24
				37.78	72	71	71		
				30.88	90	87	58		
			2	21.23	120	128	40	475	
				14.88	180	182	28		
				12.16	220	222	23		
0.21	2 (3180)	0.70/0.46	3	53.89	52	50	137	600	min 11.81 max 47.24
				37.78	72	71	96		
				30.88	90	85	78		
			2	21.23	120	125	54	475	
				14.88	180	179	38		
				12.16	220	217	31		

- 1 FLA = full load amps at 230volts and 460 volts, respectively.
- 2 Use "Nominal Speed" to specify pulley. "Actual belt speed" is presented (for unlagged pulley) to assist with process design calculations. See "Actual Speed vs Nominal Speed" section in Technical Precautions. Note that actual belt speed increases when lagging is used due to increased pulley diameter.
- 3 Pulley must not be subjected to radial load exceeding "Maximum Radial Load" defined above. See "Belt Tension" section in Technical Precautions.

# Motorized Pulley 80LS

Ø 3.21 in. (80 mm), with steel helical gearbox



## Spare Parts List and Sectional Drawings

1	Pulley shell	15.1*	Rotor assembly	95	Straight connector
2	Bearing housing	23	Rear flange	146	Washer
3	Bearing housing	28	Ball bearing	196	Key
12*	Gearbox (3 stage shown)	29	Ball bearing	200	Rubber seal
13	Front shaft	40	Hexagon socket screw	201	Encoder (if applicable)
14	Rear shaft	53.1	Pressure nipple		
15*	Stator	68	Key		

## 80LS Standard: 3 stage gearbox with power cord

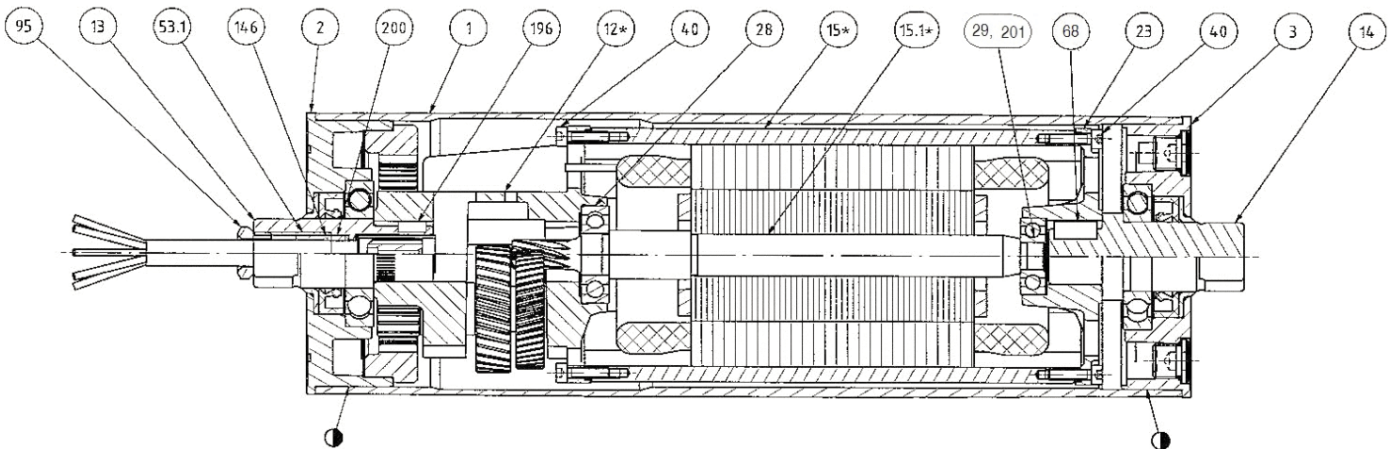

\* Variable parts for other speeds and powers



# Motorized Pulley 80LS

Ø 3.21 in. (80 mm), with steel helical gearbox

## Spare Parts List and Sectional Drawings for Gearbox

1	Gear housing	6	Distance nipple	200	Retaining ring
2	Output pinion shaft	7	Distance nipple	201	Retaining ring
3	Intermediate pinion shaft	100	Needle bearing	300	Key
4	Input wheel	101	Ball bearing	301	Key
5	Intermediate wheel	102	Inner ring		

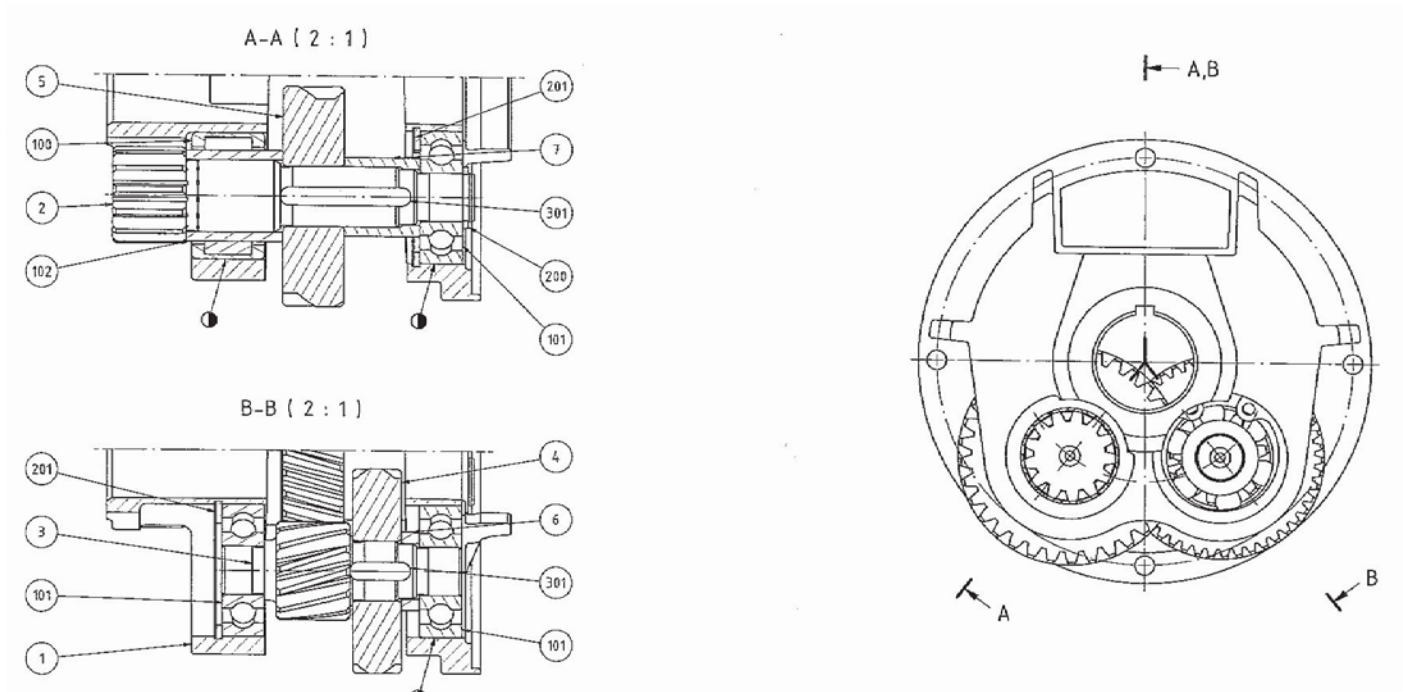



# Motorized Pulley 80LS

Ø 3.21 in. (80 mm), with steel helical gearbox



## Spare Parts List and Sectional Drawing for End Housing

- 1 End housing
- 2 Deflection seal
- 3 Oil plug
- 4 Oil plug with magnet
- 100 Ball bearing
- 200 Shaft seal

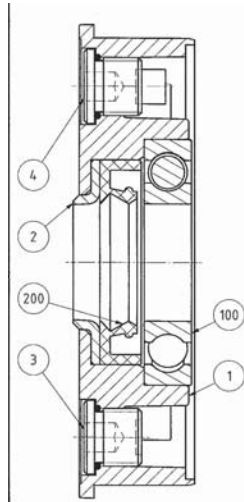







## Motorized Pulley 113LP

Ø 4.47 in. (113 mm), with planetary gearbox  
in polymer or polymer / steel combination

### Product description

This Motorized Pulley is the ideal drive for light and medium duty conveyors, for non-continuous use.

### Characteristics

- Asynchronous 3 phase or 1 phase AC induction motor
- Integral motor protection
- Planetary gearbox in polymer or polymer / steel combination
- Low noise operation
- Light and distributed weight
- Maintenance free
- Lifetime lubrication
- Reversible operation
- Motorized Pulleys with RL greater than 27.80 inches have reinforced shaft.

### Applications

- Small package handling conveyors with high duty cycle
- Transfer conveyors
- Dynamic weighing equipment
- Metal detectors
- Recycling equipment
- Pharmaceutical equipment
- Food processing equipment
- Positive drive and modular belt conveyors
- Dry, humid and wash down applications

### Technical data

<b>Type of Motor</b>	Asynchronous squirrel-cage, IEC 34 (VDE 0530)
<b>Insulation class of motor windings</b>	Class F, IEC 34 (VDE 0530)
<b>Available power supplies*</b>	115v/1ph/60Hz, 230v/1ph/60Hz, 230v/3ph/60Hz, 460v/3ph/60Hz
<b>Seal protection rating</b>	IP66
<b>Thermal protection</b>	Bimetallic contact
<b>Allowable ambient temperature, 3-phase motor</b>	+41° F to +104° F
<b>Allowable ambient temperature, 1-phase motor</b>	+50° F to +104° F
<b>Max. Roller length (RL)</b>	47.72 in

\* Other power supply voltages and frequencies are available.





## Motorized Pulley 113LP

Ø 4.47 in. (113 mm), with planetary gearbox  
in polymer or polymer / steel combination

### Materials

Component	Version	Aluminum	Steel	Stainless Steel	Brass /Nickel
<b>Shell</b>	Crowned	Std	Opt	Opt	-
	Cylindrical	Opt	Opt	Opt	-
	Special crowns with grooves	Opt	Opt	Opt	-
<b>End housing</b>	Standard	Std	-	Opt	-
<b>Shaft cap</b>	Standard (with straight/90° free position cable)	Std	-	-	-
<b>Electrical termination</b>	Power cord with straight connector	-	-	Opt	Opt
	Power cord with 90° connector	-	-	Opt	Opt
	Power cord with elbow connector	Opt	-	Opt	-

### Options

- Dynamic balancing
- Food grade oil (EU, FDA and USDA)
- Non-horizontal mounting (more than  $\pm 5^\circ$ )
- For special versions, please contact RULMECA

### Power Cord Specifications

- Standard, unshielded, 6 feet long
- Other types & lengths available upon request



# Motorized Pulley 113LP

Ø 4.47 in. (113 mm), with planetary gearbox  
in polymer or polymer / steel combination

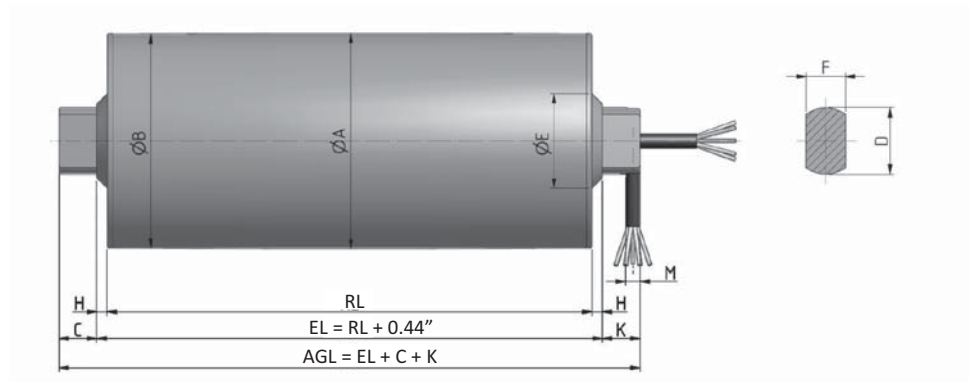

Motorized Pulley Standard Version.

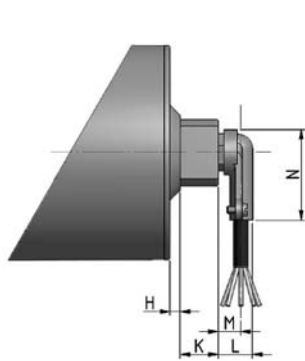

Elbow connector in aluminum.

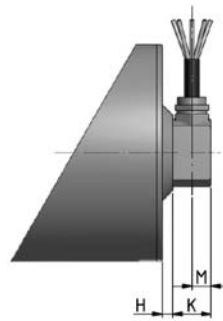

Cable connection 90°.

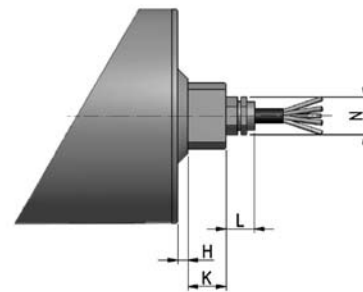

Straight connector.

Type/Option	A in	B in	C in	D in	E in	F in	G in	H in	K in	L in	M in	N in	Q in	T in
<b>Motorized Pulley Standard Version</b>	4.47	4.43	0.79	1.38	1.97	0.83		0.22	0.79		0.31			
<b>Elbow Connector in aluminum</b>									0.79	0.71	0.47	1.89		
<b>Cable Connector 90°</b>									0.79		0.39			
<b>Straight Connector</b>									0.79	0.59		0.79		

<b>Std. RL shell lengths (in)</b>	11.81	13.78	15.75	17.72	19.69	21.65	23.62	25.60	27.56	29.53	31.50	+ 1.97 in up to	47.24
<b>Average weight (lbs)</b>	15.0	15.5	16.5	17.5	18.0	19.0	19.5	20.5	21.5	24.0	25.0	+ 1.0 lb up to	33.0

- Min lengths: see table at page 8.
- Max length: 47.72in
- Weights are approximate due to different shell executions and motor powers

# Motorized Pulley 113LP

Ø 4.47 in. (113 mm), with planetary gearbox  
in polymer or polymer / steel combination



Power & Speed Combinations: 3 phase												
Power HP	Poles	FLA (amps) <sup>1</sup>	No. Gear Stages	Gear Ratio	Nominal belt speed at Full Load 60 Hz fpm <sup>2</sup>	Actual belt speed at Full Load 60 Hz fpm <sup>2</sup>	Belt Pull lbs	Max. Radial Load T1 + T2 lbs <sup>3</sup>	RL in			
0.08	4	0.8/0.4	4	267.7	6	6	202*	450	min 10.08 max 47.24			
				204.5	8	8	199*					
				120.2	12	12	187					
				92.9	14	16	141					
			3	63.4	26	24	94					
				48.4	30	30	75					
				37.3	38	40	56					
				28.6	48	52	43					
				24.9	60	62	36					
				21.9	76	72	31					
				2	14.9	96	100			22		
					11.3	150	139			16		
0.16	4	1.0/0.7	3	63.4	24	24	187	450	min 10.08 max 47.24			
				48.4	30	30	150					
				37.3	38	40	112					
				28.6	48	52	87					
				24.9	60	62	72					
				21.9	76	72	62					
			2	14.9	96	100	45					
				11.3	150	139	33					
				3	37.3	38	40			169	450	min 10.08 max 47.24
					28.6	48	52			130		
					24.9	60	62			109		
					21.9	76	72			94		
2	14.9	96	100		67							
	11.3	150	139		49							
	9.9	165	163	42								
	8.7	192	183	37								
0.24	4	1.3/0.9	3	7.5	240	211	32	340	min 10.08 max 47.24			
				2	28.6	48	52			180		
					24.9	60	62			151		
					21.9	76	72			130		
			14.9		96	100	94					
			3	11.3	150	139	68					
				9.9	165	163	58					
				8.7	192	183	52					
7.5	240	211		45								
0.34	4	1.6/1.2	3	21.9	76	72	193	450	min 10.87 max 47.24			
				2	14.9	96	100			139		
					11.3	150	139			100		
			9.9		165	163	86					
			8.7		192	183	76					
			7.5		240	211	66					
			3		21.9	76	72			193		
					14.9	96	100			139		
				11.3	150	139	100					
				9.9	165	163	86					
0.5	4	2.1/1.2	2	8.7	192	183	76	340	min 11.57 max 47.24			
				7.5	240	211	66					

- 1 FLA = full load amps at 230 volts & 460 volts, respectively.
- 2 Use "Nominal Speed" to specify pulley. "Actual belt speed" is presented (for unlagged pulley) to assist with process design calculations. See "Actual Speed vs Nominal Speed" section in Technical Precautions. Note that actual belt speed increases when lagging is used due to increased pulley diameter.
- 3 Pulley must not be subjected to radial load exceeding "Maximum Radial Load" defined above. See "Belt Tension" section in Technical Precautions.
- \* Note that belt pull is restricted in certain (slow speed) cases. Contact Rulmeca for more information.



# Motorized Pulley 113LP

Ø 4.47 in. (113 mm), with planetary gearbox  
in polymer or polymer / steel combination

Power & Speed Combinations: 1 phase														
Power HP	Poles	FLA (amps) <sup>1</sup>	No. Gear Stages	Gear Ratio	Actual belt speed at Full Load 60 Hz fpm <sup>2</sup>	Nominal belt speed at Full Load 60 Hz fpm <sup>2</sup>	Belt Pull lbs	Max. Radial Load T1 + T2 lbs <sup>3</sup>	RL in					
0.08	4	NA/0.07	4	267.7	6	6	202*	450	min 10.08 max 47.24					
				204.5	8	8	199*							
				120.2	12	12	187							
				92.9	14	16	141							
			3	63.4	24	24	94							
				48.4	30	30	75							
				37.3	38	40	56							
				28.6	48	52	43							
				24.9	60	62	36							
				21.9	76	72	31							
				2	14.9	96	100			22				
					11.3	150	139			16				
			0.16	4	2.5/0.09	3	63.4			24	24	187	450	min 10.08 max 47.24
							48.4			30	30	150		
37.3	38	40					112							
28.6	48	52					87							
24.9	60	62					72							
21.9	76	72					62							
2	14.9	96				100	45							
	11.3	150				139	33							
	9.9	165				163	28							
	37.3	38				40	169							
0.24	4	2.9/2.3	3	28.6	48	52	130	450	min 10.87 max 47.24					
				24.9	60	62	109							
				21.9	76	72	94							
				14.9	96	100	67							
			2	11.3	150	139	49							
				9.9	165	163	42							
				8.7	192	183	37							
				7.5	240	211	32							
				28.6	48	52	180			450	min 11.57 max 47.24			
				24.9	60	62	151							
21.9	76	72	130											
2	14.9	96	100	94										
	11.3	150	139	68										
	9.9	165	163	58										
	8.7	192	183	52										
	7.5	240	211	45										

1 FLA = full load amps at 115 volts & 230 volts, respectively.

2 Use "Nominal Speed" to specify pulley. "Actual belt speed" is presented (for unlagged pulley) to assist with process design calculations. See "Actual Speed vs Nominal Speed" section in Technical Precautions. Note that actual belt speed increases when lagging is used due to increased pulley diameter.

3 Pulley must not be subjected to radial load exceeding "Maximum Radial Load" defined above. See "Belt Tension" section in Technical Precautions.

\* Note that belt pull is restricted in certain (slow speed) cases. Contact Rulmeca for more information.



# Motorized Pulley 113LP

Ø 4.47 in. (113 mm), with planetary gearbox  
in polymer or polymer / steel combination

## Spare Parts List and Sectional Drawings

1	Shaft cap (rear)	14	Wavey washer	27	Tywrap
2	Set screw	15	Flat washer	28	O-ring
3	Ball bearing	16	Planet gear (short)	29	Set screw
4	O-ring	17	Circlips	30	Compression seal
5	Oil seal	18	Ball bearing	31	Straight connector
6	Ring gear	19	Stator housing	32	End housing
7	Gear holder	20	Rotor	33	Shell
8	Roll pin	21	Stator	34	Shaft
9	Planet gear (long)	22	Stator housing	35	Rotor journal bearing
10	Planet gear (short)	23	Stator bolt	36	Rotor shaft
11	Sun gear (long)	24	Nut	37	Shaft cap (front)
12	Sun gear (short)	25	Rivet	38	Power cord
13	Gear carrier	26	Dowel pin	39	X-ring

## 113LP Standard:

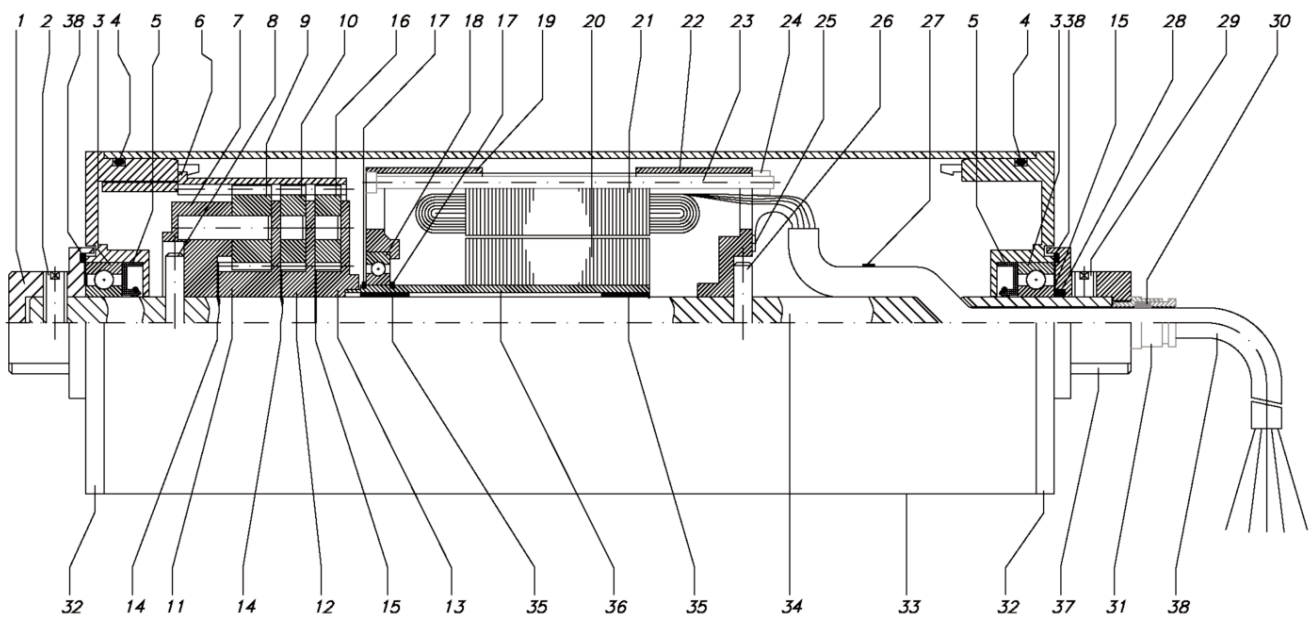



# Motorized Pulley 113LS

Ø 4.53 in. (113 mm), with helical steel gearbox

## Product description

This Motorized Pulley is ideal for light duty industrial applications.

## Characteristics

- Asynchronous 3 phase AC induction motor
- Integral motor protection
- Hardened steel helical gearbox
- Low noise operation
- Reversible operation
- Motorized Pulleys with RL greater than 31.50 inches have reinforced shaft.

## Applications

- Package handling conveyors with frequent use
- Airport luggage check-in conveyors
- Dynamic weighing equipment
- Metal detectors
- Pharmaceutical equipment
- Food processing equipment
- Positive drive and modular belt conveyors
- Dry, humid and wash down applications

Technical data	
<b>Type of Motor</b>	Asynchronous squirrel-cage, IEC 34 (VDE 0530)
<b>Insulation class of motor windings</b>	Class F, IEC 34 (VDE 0530)
<b>Available power supplies*</b>	230v/3ph/60Hz, 460v/3ph/60Hz
<b>Seal protection rating (standard)</b>	IP66
<b>Seal protection rating (optional)</b>	IP69
<b>Thermal protection</b>	Bimetallic contact
<b>Allowable ambient temperature, 3-phase motor</b>	+41° F to +104° F
<b>Max. Roller length (RL)</b>	55.12 in

\* Other power supply voltages and frequencies are available.



# Motorized Pulley 113LS

Ø 4.53 in. (113 mm), with helical steel gearbox



## Materials

Component	Version	Aluminum	Steel	Stainless steel
<b>Shell</b>	Crowned	-	Opt	Std
	Cylindrical	-	Opt	Std
	Cylindrical with key (for sprockets)	-	Opt	Opt
	Special profiles	-	Opt	Opt
<b>End housing</b>	Standard	Std	-	Opt
<b>Shaft</b>	Standard	-	-	Std
	Cross-drilled and threaded, M6	-	-	Opt
<b>Electrical termination</b>	Power cord with straight ss connector	-	-	Std
	Power cord with elbow ss connector	-	-	Std
	Power cord w/shaft cap & ss elbw connector	-	-	Std
	Terminal box	Std	-	Opt

## Options

- Rubber lagging for standard belts
- Profiled lagging for positive drive belts
- Profiled ss shells for positive drive belts
- Mechanical backstop
- Special smooth stainless steel end housings, slotted screw oil plugs, Viton® shaft seals and PTFE deflection seals (option TS8N) for IP69 sealing.
- Electromagnetic brake
- Rectifier
- Encoder
- Food grade oil (EU, FDA and USDA)
- Non-horizontal mounting (more than ± 5°)

## Power Cord Specifications

- Standard, shielded, 10 feet long
- Other types & lengths available upon request



# Motorized Pulley 113LS

Ø 4.53 in. (113 mm), with helical steel gearbox

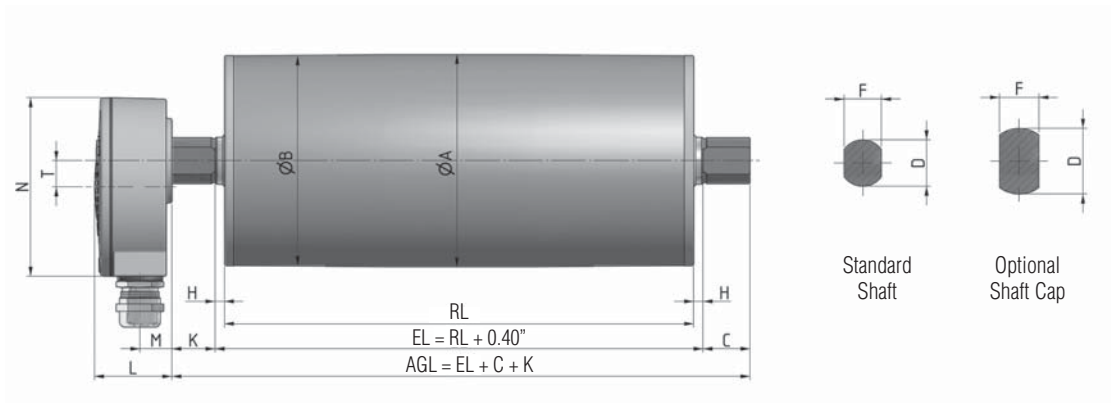

Standard Motorized Pulley with aluminum terminal box

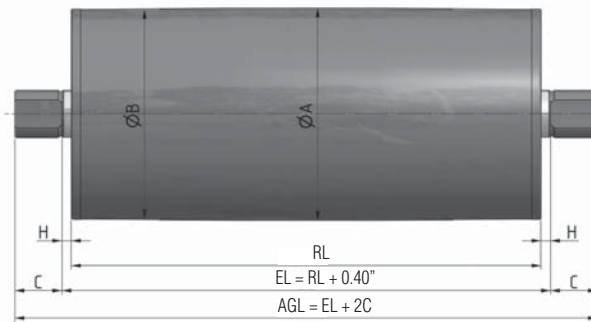

Idler Pulley.

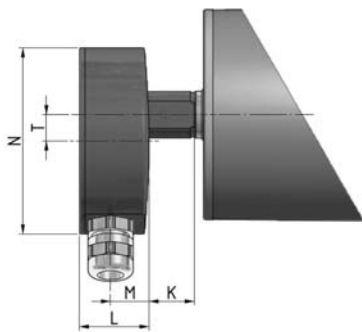

Terminal box in stainless steel.

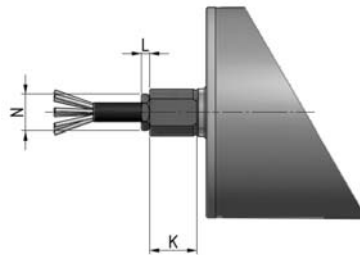

Straight connector in stainless steel.

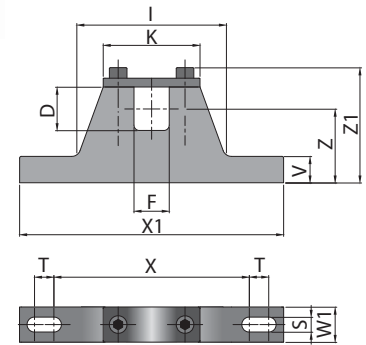

MC = Mounting bracket center-to-center spacing =  $RL + 1.19$ "

Mounting bracket

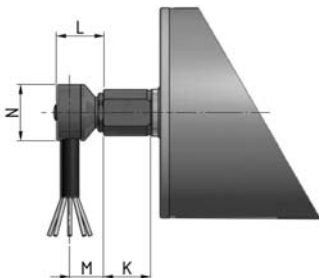

Elbow connector in stainless steel.

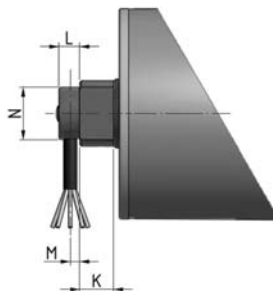

Elbow connector with shaft cap in stainless steel.

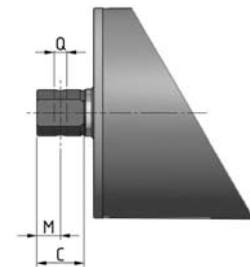

Shaft, cross-drilled and threaded.

# Motorized Pulley 113LS

Ø 4.53 in. (113 mm), with helical steel gearbox



## Dimensions for Motorized Pulley 113LS

Type/Option	A in	B in	C in	D in	E in	F in	G in	H in	K in	L in	M in	N in	Q in	T in
Standard shaft with aluminum terminal box	4.45	4.39	0.98	0.98		0.79		0.20	0.91	1.61	0.67	3.74		0.55
Terminal box in stainless steel									0.91	1.46	0.81	3.9		0.55
Standard shaft with ss straight connector									0.98	0.18		0.77		
Standard shaft with ss elbow connector									0.98	0.98	0.71	1.18		
Cross-drilled and threaded shaft									0.98		0.5		M8	
Shaft cap with ss elbow connector								0.12	0.71	0.13	0.16	1.1		

## Revised Dimensions for options

The following options increase the minimum roller length (RL)

Option	Optional RL min.
Electromagnetic brake	Standard RL min + 1.97in
Encoder - SKF	Standard RL min + 0 in
Encoder - RLS	Standard RL min +1.97in

## Dimensions, materials, and weights for Mounting Brackets

Motorized Pulley	Standard Material	Optional Material	D [in]	F [in]	I [in]	K [in]	S [in]	T [in]	V [in]	W1 [in]	X [in]	X1 [in]	Z [in]	Z1 [in]	Thread	Weight [lbs]
113LS	Aluminum	Stainless steel	0.98	0.79	3.35	2.17	0.33	0.43	0.59	0.79	4.33	5.91	1.65	2.60	M6	1.1/2.0

## Standard weights for Motorized Pulley 113LS

Power HP	Poles	standard weight [lbs] for standard RL [in]												
		9.84	11.81	13.78	15.75	17.72	19.69	21.65	23.62	25.59	27.56	31.50	35.43	39.37
0.05	12	16.0	17.5	19.5	21.0	23.0	24.5	26.0	28.0	29.5	31.0	41.5	45.0	48.0
0.09	12	---	22.0	24.0	26.0	27.5	29.0	31.0	32.5	34.0	36.0	46.0	49.5	53.0
0.11	8	16.0	17.5	19.5	21.0	23.0	24.5	26.0	28.0	29.5	31.0	41.5	45.0	48.0
0.13	6	16.0	17.5	19.5	21.0	23.0	24.5	26.0	28.0	29.5	31.0	41.5	45.0	48.0
0.20	8	---	22.0	24.0	26.0	27.5	29.0	31.0	32.5	34.0	36.0	46.0	49.5	53.0
	4	16.0	17.5	19.5	21.0	23.0	24.5	26.0	28.0	29.5	31.0	41.5	45.0	48.0
0.27	6	16.0	17.5	19.5	21.0	23.0	24.5	26.0	28.0	29.5	31.0	41.5	45.0	48.0
0.32	2	16.0	17.5	19.5	21.0	23.0	24.5	26.0	28.0	29.5	31.0	41.5	45.0	48.0
0.40	4	---	22.0	24.0	26.0	27.5	29.0	31.06	32.5	34.0	36.0	46.0	49.5	53.0
0.50	4	---	22.0	24.0	26.0	27.5	29.0	31.0	32.5	34.0	36.0	46.0	49.5	53.0
	2	---	22.0	24.0	26.0	27.5	29.0	31.0	32.5	34.0	36.0	46.0	49.5	53.0
0.75	4	---	22.0	24.0	26.0	27.5	29.0	31.0	32.5	34.0	36.0	46.0	49.5	53.0
	2	---	22.0	24.0	26.0	27.5	29.0	31.0	32.5	34.0	36.0	46.0	49.5	53.0



# Motorized Pulley 113LS

Ø 4.53 in. (113 mm), with helical steel gearbox

Power & Speed Combinations: 3 phase															
Power HP	Poles (rpm)	FLA (amps) <sup>1</sup>	No. Gear Stages	Gear Ratio	Nominal belt speed at Full Load 60 Hz fpm <sup>2</sup>	Actual belt speed at Full Load 60 Hz fpm <sup>2</sup>	Belt Pull lbs	Max. Radial Load T1 + T2 lbs <sup>3</sup>	RL in						
0.05	12 (540)	0.88/0.47	3	42.66	12	15	100	1470	min 9.84 max 55.12						
				36.35	14	17	85								
				31.36	18	20	73								
0.09	12 (520)	1.11/0.63	3	42.66	12	14	207	1470	min 11.81 max 55.12						
				36.35	14	17	177								
				31.36	18	19	152								
0.11	8 (825)	0.97/0.56	3	42.66	24	23	149	1470	min 9.84 max 55.12						
0.13	6 (1100)	0.87/0.44	3	42.66	26	30	140	1470							
				36.35	30	35	119								
				31.36	38	41	103								
				27.32	48	47	90								
				23.99	52	53	79								
2	15.17	76	84	50	1020	1470	min 9.84 max 55.12								
								12.92		96	99	42			
								11.15		120	115	37			
0.20	8 (810)	1.47/0.78	3	42.66	24	22	285	1470		min 11.81 max 55.12					
				36.35	26	26	243								
				31.36	30	30	210								
	4 (1700)	1.02/0.55	3	42.66	48	46	136	1470	min 9.84 max 55.12						
				36.35	52	54	116								
				31.36	60	63	100								
				27.32	72	72	87								
				23.99	76	83	76								
				21.18	90	93	67								
2	15.17	120	131	48	1020	1470	min 9.84 max 55.12								
								12.92	150	153	41				
								11.15	165	178	36				
0.25	6 (1120)	1.40/0.70	3	42.66	30	31	275	1470	min 11.81 max 55.12						
				31.36	38	42	202								
				27.32	48	48	176								
				23.99	52	54	155								
				21.18	60	62	137								
			2	15.17	76	86	98	1020		1470	min 11.81 max 55.12				
												12.92	96	101	83
												11.15	120	117	72

Refer to page 39 for all footnotes cited on page 38.

# Motorized Pulley 113LS

Ø 4.53 in. (113 mm), with helical steel gearbox



Power & Speed Combinations: 3 phase									
Power HP	Poles (rpm)	FLA (amps) <sup>1</sup>	No. Gear Stages	Gear Ratio	Nominal belt speed at Full Load 60 Hz fpm <sup>2</sup>	Actual belt speed at Full Load 60 Hz fpm <sup>2</sup>	Belt Pull lbs	Max. Radial Load T1 + T2 lbs <sup>3</sup>	RL in
0.33	2 (3430)	1.12/0.57	3	42.66	90	94	108	1020	min 9.84 max 55.12
				36.35	96	110	92		
				31.36	120	127	79		
				27.32	150	146	69		
			2	23.99	165	167	61	770	
				21.18	192	189	53		
				15.17	240	263	38		
				12.92	300	309	33		
0.40	4 (1700)	1.66/0.87	3	42.66	48	46	272	1470	min 11.81 max 55.12
				36.35	52	54	232		
				31.36	60	63	200		
				27.32	72	72	174		
			2	23.99	76	83	153	1020	
				21.18	90	93	135		
				15.17	120	131	97		
				12.92	150	153	82		
0.50	4 (1680)	2.03/1.01	3	42.66	48	46	339	1470	min 11.81 max 55.12
				36.35	52	54	289		
				31.36	60	62	249		
				27.32	72	72	217		
			2	23.99	76	82	191	1020	
				21.18	90	92	168		
				15.17	120	129	121		
	2 (3470)	1.51/0.76	3	12.92	150	151	103	770	
				11.15	165	175	89		
				21.18	192	191	82		
			2	15.17	240	266	58	770	
				12.92	300	313	50		
				11.15	384	362	43		
				42.66	90	94	246		
3	36.35	96	110	210					
	31.36	120	128	181					
	27.32	150	147	158					
	23.99	165	167	138					
	21.18	192	189	122					
	15.17	240	264	88					
2	12.92	300	310	75	770				
	11.15	384	359	64					

- 1 FLA = full load amps at 230volts and 460 volts, respectively.
- 2 Use "Nominal Speed" to specify pulley. "Actual belt speed" is presented (for unlagged pulley) to assist with process design calculations. See "Actual Speed vs Nominal Speed" section in Technical Precautions. Note that actual belt speed increases when lagging is used due to increased pulley diameter.
- 3 Pulley must not be subjected to radial load exceeding "Maximum Radial Load" defined above. See "Belt Tension" section in Technical Precautions.



# Motorized Pulley 113LS

Ø 4.53 in. (113 mm), with helical steel gearbox

## Spare Parts List and Sectional Drawings

1	Pulley shell	15.1*	Rotor assembly	53.1	Pressure nipple
2	Bearing housing	23	Rear flange	68	Key
3	Bearing housing	24	Double lip seal	95	Straight connector
8	Gearbed rim	26	Ball bearing	140	Deflection seal
12*	Gearbox (3 stage shown)	29	Ball bearing	146	Washer
13	Front shaft	40	Hexagon socket screw	196	Key
14	Rear shaft	51	Oil plug	200	Rubber seal
15*	Stator	52	Oil plug with magnet	201	Encoder (if applicable)

### 113LS Standard: 3 stage gearbox with power cord

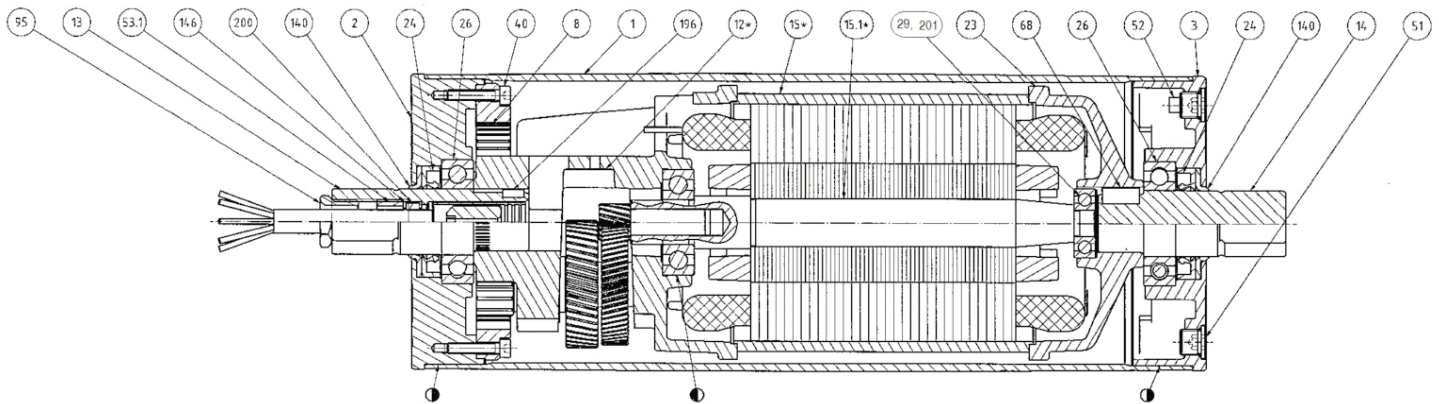

\* Variable parts for other speeds and powers

### Motor stator cross section

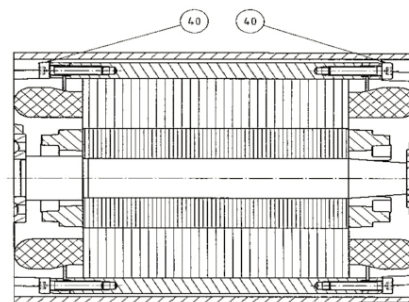



# Motorized Pulley 113LS

Ø 4.53 in. (113 mm), with helical steel gearbox



## Spare Parts List and Sectional Drawings

1	Front shaft	103	Screw	146	Washer
5	Bearing housing complete w/geared rim	110	Screw	148	Washer
10	Terminal box - bottom part	111	Screw	200	Rubber seal
11	Terminal box cover	136	O-ring/Rubber seal	229	WAGO clamp terminals
53	Cable side nipple (cable option)	138	Rubber seal	230	Fixing bolts
53.1	Nipple (terminal box)	140	Deflection seal		
63	Ball bearing	142	Double lip seal		

### 113LS Standard: with terminal box

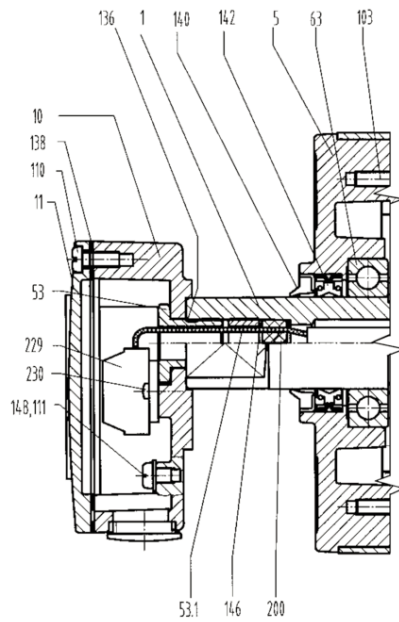







# Motorized Pulley 138LS

Ø 5.45 in. (138 mm), with helical steel gearbox

## Product description

This Motorized Pulley is ideal for most package handling and food processing applications.

## Characteristics

- Asynchronous 3 phase AC induction motor
- Integral motor protection
- Hardened steel helical gearbox
- Low noise operation
- Reversible operation
- Motorized Pulleys with RL greater than 31.50 inches have reinforced shaft.

## Applications

- Package handling conveyors with frequent use
- Airport luggage check-in conveyors
- Dynamic weighing equipment
- Metal detectors
- Pharmaceutical equipment
- Food processing equipment
- Positive drive and modular belt conveyors
- Dry, humid and wash down applications

## Technical data

Technical data	
<b>Type of Motor</b>	Asynchronous squirrel-cage, IEC 34 (VDE 0530)
<b>Insulation class of motor windings</b>	Class F, IEC 34 (VDE 0530)
<b>Available power supplies*</b>	115v/1ph/60Hz, 230v/1ph/60Hz, 230v/3ph/60Hz, 460v/3ph/60Hz
<b>Seal protection rating (standard)</b>	IP66
<b>Seal protection rating (optional)</b>	IP69
<b>Thermal protection</b>	Bimetallic contact
<b>Allowable ambient temperature, 3-phase motor</b>	-13° F to +104° F
<b>Max. Roller length (RL)</b>	70.87 in

\* Other power supply voltages and frequencies are available.



# Motorized Pulley 138LS

Ø 5.45 in. (138 mm), with helical steel gearbox



## Materials

Component	Version	Aluminum	Steel	Stainless steel
<b>Shell</b>	Crowned	-	Std	Opt
	Cylindrical	-	Std	Opt
	Cylindrical with key (for sprockets)	-	Opt	Opt
	Special profiles	-	Opt	Opt
<b>End housing</b>	Standard	Std	-	Opt
<b>Shaft</b>	Standard	-	Std	Opt
	Cross-drilled and threaded, M6	-	Opt	Opt
<b>Electrical termination</b>	Power cord with straight ss connector	-	-	Std
	Power cord with elbow ss connector	-	-	Std
	Terminal box	Std	-	Opt

## Options

- Rubber lagging for standard belts
- Profiled lagging for positive drive belts
- Profiled ss shells for positive drive belts
- Mechanical backstop
- Special smooth stainless steel end housings, slotted screw oil plugs, Viton® shaft seals and PTFE deflection seals (option TS8N) for IP69 sealing.
- Special smooth stainless steel end housings, slotted screw oil plugs, labyrinth seals (option TS7N) for IP66 sealing.
- Electromagnetic brake
- Rectifier
- Encoder
- Food grade oil (EU, FDA and USDA)
- Non-horizontal mounting (more than ± 5°)

## Power Cord Specifications

- Standard, shielded, 10 feet long
- Other types & lengths available upon request



# Motorized Pulley 138LS

Ø 5.45 in. (138 mm), with helical steel gearbox

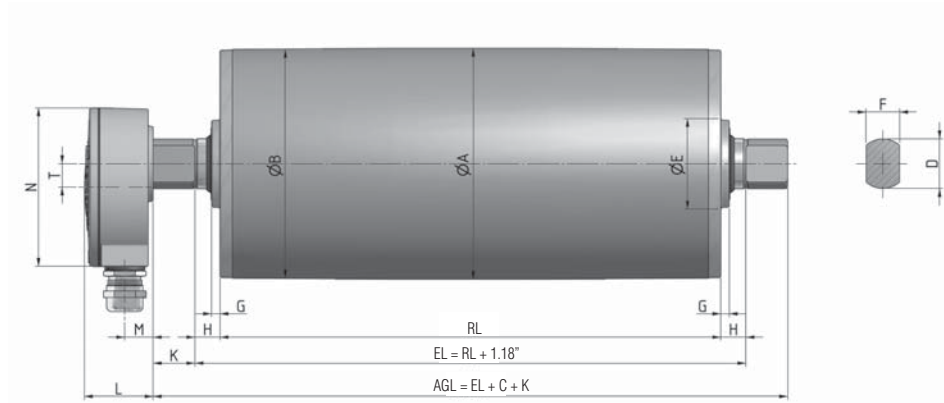

Standard Motorized Pulley with aluminum terminal box

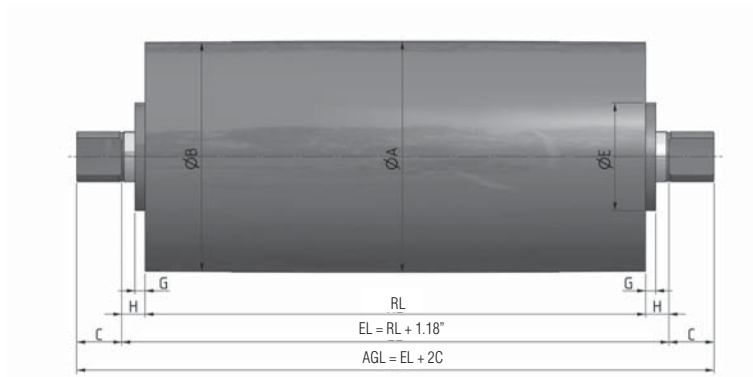

Idler Pulley in stainless steel

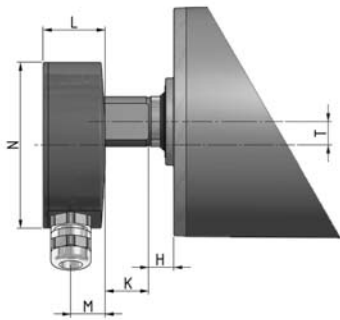

Terminal box in stainless steel.

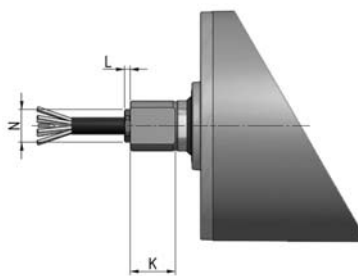

Straight connector in stainless steel.

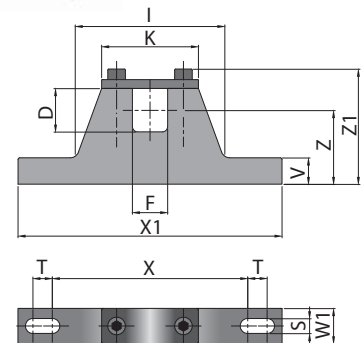

MC = Mounting bracket center-to-center spacing =  $RL + 2.12''$

Mounting bracket

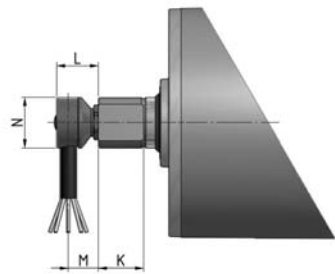

Elbow connector in stainless steel.

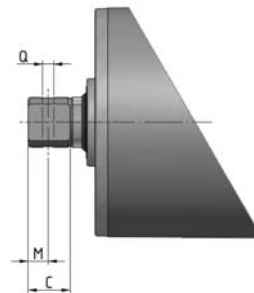

Shaft, cross-drilled and threaded.

# Motorized Pulley 138LS

Ø 5.45 in. (138 mm), with helical steel gearbox



## Dimensions for Motorized Pulley 138LS

Type/Option	A in	B in	C in	D in	E in	F in	G in	H in	K in	L in	M in	N in	Q in	T in
Standard version with aluminum terminal box	5.45	5.39	0.98	1.18	2.13	0.79	0.20	0.59	0.98	1.61	0.67	3.74		0.55
Terminal box in stainless steel									0.98	1.46	0.81	3.90		0.55
Idler pulley in stainless steel					2.54		0.24		1.06					
Straight connector in stainless steel									1.06	0.14		0.77		
Elbow connector in stainless steel									1.06	0.94	0.71	1.18		
Cross-drilled and threaded shaft									1.06		0.47		M8	

## Revised Dimensions for options

The following options increase the minimum roller length (RL)

Option	Optional RL min.
Electromagnetic brake	Standard RL min + 1.97in
Encoder - SKF	Standard RL min + 0 in
Encoder - RLS	Standard RL min +1.97in

## Dimensions, materials, and weights for Mounting Brackets

Motorized Pulley	Standard Material	Optional Material	D [in]	F [in]	I [in]	K [in]	S [in]	T [in]	V [in]	W1 [in]	X [in]	X1 [in]	Z [in]	Z1 [in]	Thread	Weight [lbs]
138LS	Cast iron with black powder coat	Stainless steel	1.18	0.79	3.39	2.24	0.43	0.67	0.47	0.94	4.33	7.09	1.75	2.83	M8	3.1

## Standard weights for Motorized Pulley 138LS

Power HP	Poles	Standard weight [lbs] for standard RL [in]													
		11.81	12.60	13.78	15.75	17.72	19.69	21.65	23.62	25.59	27.56	29.53	31.50	35.43	39.37
0.13	12	31.0	32.0	33.0	35.0	37.5	39.5	42.0	44.0	47.5	50.5	53.0	55.0	59.5	64.0
0.25	8	31.0	32.0	33.0	35.0	37.5	39.5	42.0	44.0	47.5	50.5	53.0	55.0	59.5	64.0
0.32	6	31.0	32.0	33.0	35.0	37.5	39.5	42.0	44.0	47.5	50.5	53.0	55.0	59.5	64.0
0.50	6	---	33.0	34.5	36.5	38.5	41.0	43.0	45.0	48.5	52.0	54.0	56.0	60.5	65.0
	4	31.0	32.0	33.0	35.0	37.5	39.5	42.0	44.0	47.5	50.5	53.0	55.0	59.5	64.0
0.75	2	31.0	32.0	33.0	35.0	37.5	39.5	42.0	44.0	47.5	50.5	53.0	55.0	59.5	64.0
1.00	4	---	33.0	34.5	36.5	38.5	41.0	43.0	45.0	48.5	52.0	54.0	56.0	60.5	65.0
	2	31.0	32.0	33.0	35.0	37.5	39.5	42.0	44.0	47.5	50.5	53.0	55.0	59.5	64.0
1.34	2	---	---	36.5	38.5	41.0	43.0	45.0	47.4	50.5	54.0	56.0	58.5	63.0	67.0



# Motorized Pulley 138LS

Ø 5.45 in. (138 mm), with helical steel gearbox

Power & Speed Combinations: 3 phase										
Power HP	Poles (rpm)	FLA (amps) <sup>1</sup>	No. Gear Stages	Gear Ratio	Nominal belt speed at Full Load 60 Hz fpm <sup>2</sup>	Actual belt speed at Full Load 60 Hz fpm <sup>2</sup>	Belt Pull lbs	Max. Radial Load T1 + T2 lbs <sup>3</sup>	RL in	
0.13	12 (550)	1.5/0.7	3	78.40	10	10	424	1870	min 11.81 max 72.83	
				66.00	12	12	357			
				52.96	14	15	287			
			2	29.56	24	26	160			
0.25	8 (835)	2.1/1.1	3	66.00	18	18	424	1870	min 11.81 max 72.83	
				52.96	24	22	340			
				43.65	30	27	280			
			2	29.56	38	40	190	1090		
			25.20	48	47	162				
0.33	6 (1140)	1.5/0.7	3	66.00	24	24	414	1870	min 11.81 max 72.83	
				52.96	30	30	332			
				43.65	38	37	274			
			2	29.56	48	54	185	1090		
			25.20	60	64	158				
			20.22	76	80	127				
0.50	6 (1145)	2.5/1.2	3	51.85	30	31	499	1870	min 12.60 max 72.83	
	4 (1710)	2.2/1.1		66.00	38	37	425	1090	min 11.81 max 72.83	
				52.96	48	46	341			
			43.65	60	55	281				
			29.56	76	82	190				
			25.20	96	96	162				
			20.22	120	119	130				
			16.67	150	145	107				
	12.44	192	194	80	820					
	0.75	2 (3380)	2.4/1.2	3	77.41	60	62	375	1090	min 11.81 max 72.83
66.00					76	72	320			
52.96					96	90	257			
43.65					120	109	211			
2				29.56	150	161	143	820		
25.20				192	189	122				
20.22				240	236	98				
16.67				300	286	81				
12.44				384	384	60				
1.00	4 (1690)	3.6/1.8	3	52.96	48	45	700	1090	min 12.60 max 72.83	
				43.65	60	55	577			
				32.59	76	73	431			
				25.20	96	95	333			
			2	20.22	120	118	267			
			16.67	150	143	220				
	2 (3450)	3.0/1.5	2	25.20	192	193	163	820		min 13.78 max 72.83
				20.22	240	241	131			
				16.67	300	292	108			
				12.44	384	392	81			

Refer to page 49 for all footnotes cited on page 48.



# Motorized Pulley 138LS

Ø 5.45 in. (138 mm), with helical steel gearbox



Power & Speed Combinations: 3 phase									
Power HP	Poles (rpm)	FLA (amps) <sup>1</sup>	No. Gear Stages	Gear Ratio	Nominal belt speed at Full Load 60 Hz fpm <sup>2</sup>	Actual belt speed at Full Load 60 Hz fpm <sup>2</sup>	Belt Pull lbs	Max. Radial Load T1 + T2 lbs <sup>3</sup>	RL in
1.33	2 (3440)	4.0/2.0	3	52.96	96	92	458	1090	min 13.78 max 72.83
				43.65	120	111	378		
				29.56	150	164	256		
			2	25.20	192	193	218	820	
				20.22	240	240	175		
				16.67	300	291	144		
				12.44	384	390	108		
				10.00	480	486	87		

- 1 FLA = full load amps at 230volts and 460 volts, respectively.
- 2 Use "Nominal Speed" to specify pulley. "Actual belt speed" is presented (for unlagged pulley) to assist with process design calculations. See "Actual Speed vs Nominal Speed" section in Technical Precautions. Note that actual belt speed increases when lagging is used due to increased pulley diameter.
- 3 Pulley must not be subjected to radial load exceeding "Maximum Radial Load" defined above. See "Belt Tension" section in Technical Precautions.



# Motorized Pulley 138LS

Ø 5.45 in. (138 mm), with helical steel gearbox

## Spare Parts List and Sectional Drawings

1	Front shaft	53	Cable side nipple (cable option)	110	Screw
3	Rear flange	53.1	Nipple (terminal box)	111	Screw
5	Bearing housing complete w/geared rim	55	Spacer bushing	113	Screw
7	Bearing housing rear side	56	Spacer bushing	114	Socket set screw
8	Gearbox	63	Ball bearing	115	Oil plug with magnet
10	Terminal box - bottom part	64	Needle bearing	126	Key
11	Terminal box cover	65-70	Ball bearing	127	Key
12	Shell	71	Inner race	131	Key
16	Rear shaft	73	Locking ring	132	Key
19	Input wheel	74	Locking ring	136	O-ring/Rubber seal
20	Output pinion	84	Locking ring	138	Rubber seal
22	Geared rim	86	Locking ring	139	Grease nipple
23	Intermediate pinion shaft	93	Elbow or straight connector	140	Deflection seal
24	Intermediate wheel	102	Screw	142	Double lip seal
31	Labyrinth seal cover	103	Screw	143	O-ring

## 138LS Standard: 2 stage gearbox with terminal box

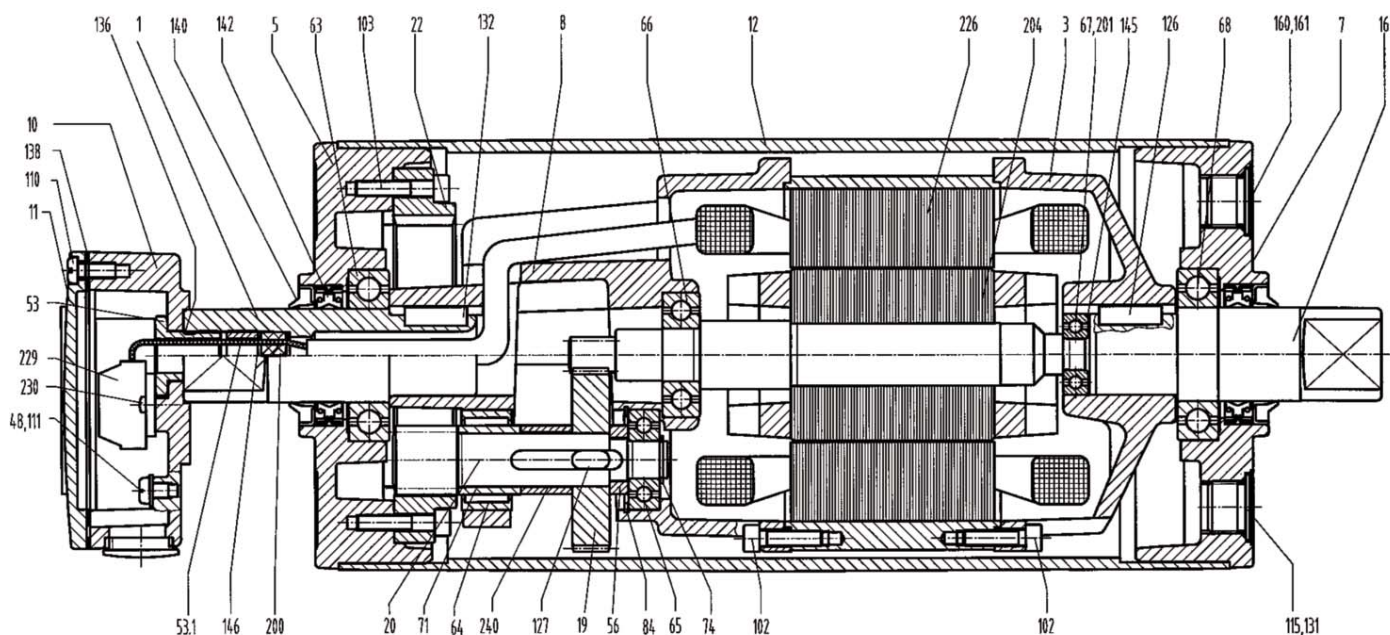

# Motorized Pulley 138LS

Ø 5.45 in. (138 mm), with helical steel gearbox



## Spare Parts List and Sectional Drawings (cont.)

145	Distance washer	161	O-ring	210	Fixing guard
146	Washer	163	O-ring	223	Cable
148	Washer	167	Screw	226	Stator complete
150	Electromagnetic brake	200	Rubber seal	229	WAGO clamp terminals
150.1	Friction disc	201	Encoder (if applicable)	230	Fixing bolts
156	Rectifier (not shown)	204	Rotor complete with pinion	240	Distance ring
160	Oil plug	208	Stainless steel cover gear end		

**SS oil plug**

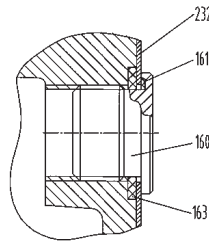

**Cable version with SS elbow connector**

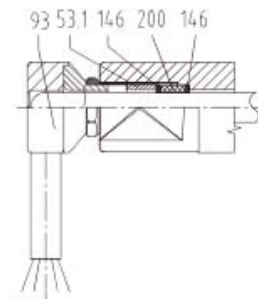

**Stainless steel version TS7N cable option with straight connector**

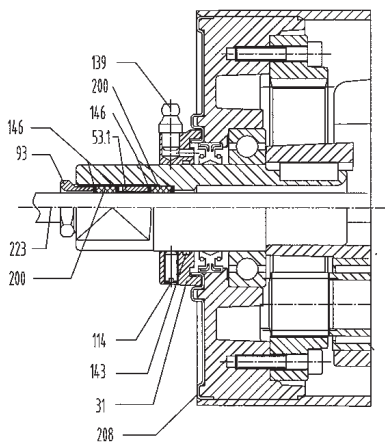

**3 stage gearbox**

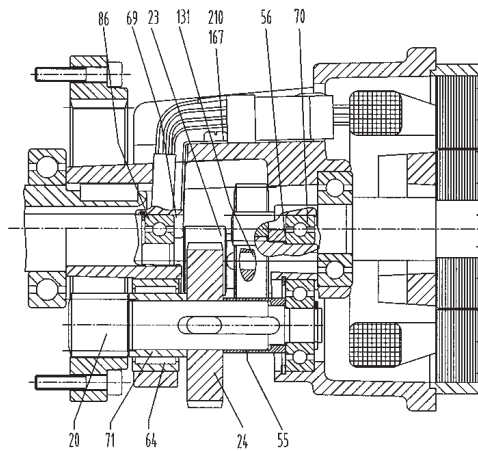

**Electromagnetic brake**

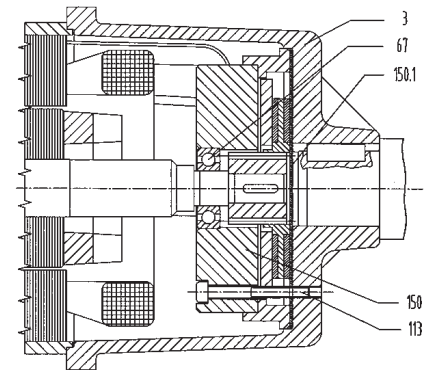







# Motorized Pulley 165LS

Ø 6.50 in. (165 mm), with helical steel gearbox

## Product description

This Motorized Pulley is ideal for longer or inclined heavy duty unit handling and food processing conveyors.

## Characteristics

- Asynchronous 3 phase AC induction motor
- Integral motor protection
- Hardened steel helical gearbox
- Low noise operation
- Reversible operation

## Applications

- Package handling conveyors with frequent use
- Logistics applications
- Dynamic weighing equipment
- Telescopic conveyors
- Agricultural conveyors
- Food processing equipment
- Positive drive and modular belt conveyors
- Dry, humid and wash down applications

Technical data	
<b>Type of Motor</b>	Asynchronous squirrel-cage, IEC 34 (VDE 0530)
<b>Insulation class of motor windings</b>	Class F, IEC 34 (VDE 0530)
<b>Available power supplies*</b>	115v/1ph/60Hz, 230v/1ph/60Hz, 230v/3ph/60Hz, 460v/3ph/60Hz
<b>Seal protection rating (standard)</b>	IP66
<b>Seal protection rating (optional)</b>	IP69
<b>Thermal protection</b>	Bimetallic contact
<b>Allowable ambient temperature, 3-phase motor</b>	-13° F to +104° F
<b>Max. Roller length (RL)</b>	70.87 in

\* Other power supply voltages and frequencies are available.



# Motorized Pulley 165LS

Ø 6.50 in. (165 mm), with helical steel gearbox



## Materials

Component	Version	Aluminum	Steel	Stainless steel
<b>Shell</b>	Crowned	-	Std	Opt
	Cylindrical	-	Std	Opt
	Cylindrical with key (for sprockets)	-	Opt	Opt
	Special profiles	-	Opt	Opt
<b>End housing</b>	Standard	Std	-	Opt
<b>Shaft</b>	Standard	-	Std	Opt
	Cross-drilled and threaded, M6	-	Opt	Opt
<b>Electrical termination</b>	Power cord with straight ss connector	-	-	Std
	Power cord with elbow ss connector	-	-	Std
	Terminal box	Std	-	Opt

## Options

- Rubber lagging for standard belts
- Profiled lagging for positive drive belts
- Profiled ss shells for positive drive belts
- Mechanical backstop
- Special smooth stainless steel end housings, slotted screw oil plugs, Viton® shaft seals and PTFE deflection seals (option TS8N) for IP69 sealing.
- Special smooth stainless steel end housings, slotted screw oil plugs, labyrinth seals (option TS7N) for IP66 sealing.
- Electromagnetic brake
- Rectifier
- Encoder
- Food grade oil (EU, FDA and USDA)
- Non-horizontal mounting (more than ± 5°)

## Power Cord Specifications

- Standard, shielded, 10 feet long
- Other types & lengths available upon request



# Motorized Pulley 165LS

Ø 6.50 in. (165 mm), with helical steel gearbox

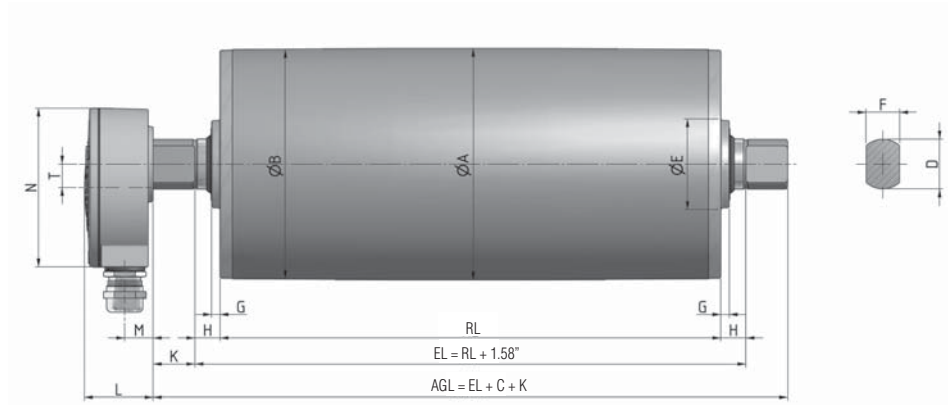

Standard Motorized Pulley with aluminum terminal box

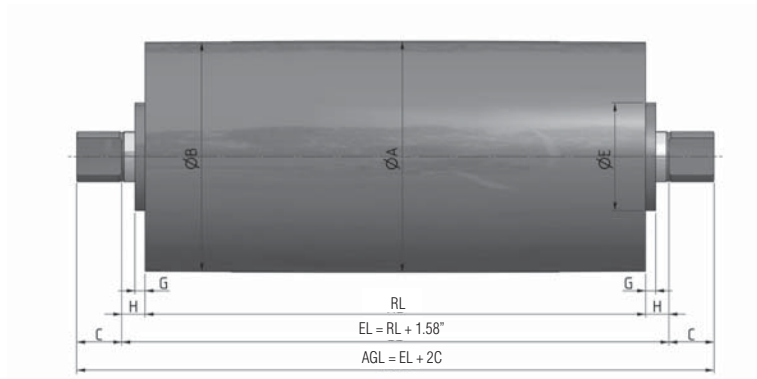

Idler Pulley in stainless steel

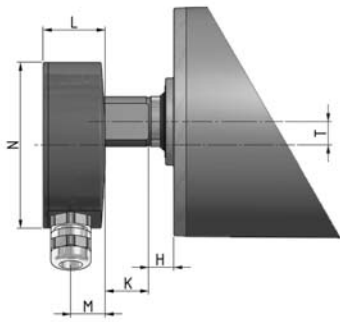

Terminal box in stainless steel.

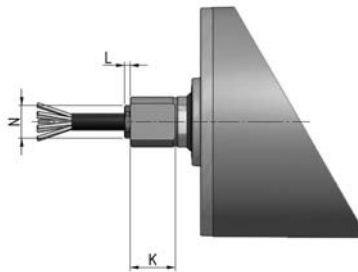

Straight connector in stainless steel.

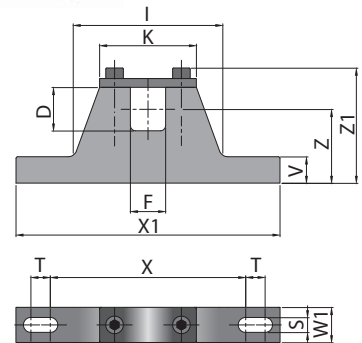

MC = Mounting bracket center-to-center spacing =  $RL + 3.15$ "

Mounting bracket

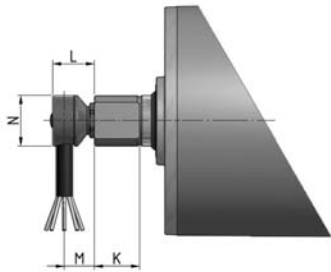

Elbow connector in stainless steel.

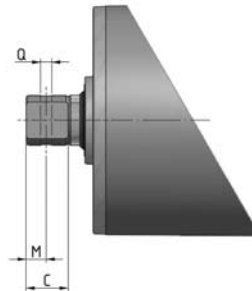

Shaft, cross-drilled and threaded.



# Motorized Pulley 165LS

Ø 6.50 in. (165 mm), with helical steel gearbox



## Dimensions for Motorized Pulley 165LS

Type/Option	A in	B in	C in	D in	E in	F in	G in	H in	K in	L in	M in	N in
Standard version with aluminum terminal box	6.50	6.44	1.77	1.57	3.15	1.18	0.39	0.79	1.77	1.61	0.67	3.74
Terminal box in stainless steel									1.77	1.46	0.81	3.90
Idler pulley in stainless steel					2.54		0.31		1.77			
Straight connector in stainless steel									1.85	0.16		1.06
Elbow connector in stainless steel									1.85	0.98	0.71	1.18
Cross-drilled and threaded shaft									1.85		0.93	

## Revised Dimensions for options

The following options increase the minimum roller length (RL)

Option	Optional RL min.
Electromagnetic brake	Standard RL min + 1.97in
Encoder - SKF	Standard RL min + 0 in
Encoder - RLS	Standard RL min + 1.97in

## Dimensions, materials, and weights for Mounting Brackets

Motorized Pulley	Standard Material	Optional Material	D [in]	F [in]	I [in]	K [in]	S [in]	T [in]	V [in]	W1 [in]	X [in]	X1 [in]	Z [in]	Z1 [in]	Thread	Weight [lbs]
165LS	Cast iron with black powder coat	Stainless steel	1.57	1.18	3.31	2.44	0.55	0.79	0.87	1.57	4.33	7.48	1.97	3.27	M8	4.4

## Standard weights for Motorized Pulley 165LS

Power HP	Poles	Standard weight [lbs] for standard RL [in]													
		13.78	15.75	17.72	19.69	21.65	23.62	25.59	27.56	29.53	31.50	33.46	35.43	37.40	39.37
0.50	6	---	66.0	69.5	73.0	75.0	77.0	79.5	82.5	86.0	88.0	90.5	93.5	97.0	99.0
	4	57.5	61.5	65.0	68.5	84.0	73.0	75.0	78.5	81.5	84.0	86.0	89.5	92.5	95.0
1.00	6	---	73.0	76.0	79.5	81.5	38.0	86.0	89.5	92.5	95.0	97.0	100.5	103.5	106.0
	4	---	68.5	71.5	75.0	77.0	79.5	81.5	85.0	88.0	90.5	92.5	96.0	99.0	101.5
1.50	4	---	75.0	78.5	81.5	84.0	86.0	88.0	91.5	95.0	97.0	99.0	102.5	106.0	108.0
	2	---	73.0	76.0	79.5	81.5	84.0	86.0	89.5	92.5	95.0	97.0	100.5	103.5	106.0
2.00	2	---	75.0	78.5	81.5	84.0	86.0	88.0	91.5	95.0	97.0	99.0	102.5	106.0	108.0
3.00	2	---	81.5	82.5	84.0	86.0	88.0	90.5	93.5	97.0	99.0	101.5	104.5	108.0	110.0



# Motorized Pulley 165LS

Ø 6.50 in. (165 mm), with helical steel gearbox

Power & Speed Combinations: 3 phase										
Power HP	Poles (rpm)	FLA (amps) <sup>1</sup>	No. Gear Stages	Gear Ratio	Nominal belt speed at Full Load 60 Hz fpm <sup>2</sup>	Actual belt speed at Full Load 60 Hz fpm <sup>2</sup>	Belt Pull lbs	Max. Radial Load T1 + T2 lbs <sup>3</sup>	RL in	
0.15	12 (570)	1.9/0.9	3	75.03	12	13	358	2500	min 15.75 max 78.74	
				61.56	14	16	294			
				49.75	18	19	238			
			2	37.93	24	26	181			
0.50	6 (1135)	1.7/1.0	3	75.03	24	26	606	4300	min 15.75 max 78.74	
				61.56	30	31	497			
				49.75	38	39	402			
	4 (1690)	2.0/1.0	3	61.56	48	47	334	2500	min 13.78 max 78.74	
				49.75	60	58	270			
				37.93	76	76	206			
				30.05	96	95	163			
			2	23.76	120	121	129			
				19.20	150	149	104			
				14.64	192	196	79			
				11.60	240	247	63	1700		
1.00	6 (1155)	4.8/2.4	3	61.56	30	32	990	4300	min 15.75 max 78.74	
				46.23	38	42	743			
	4 (1720)	3.6/1.8	3	61.56	48	47	665	2500	min 15.75 max 78.74	
				49.75	60	59	537			
				37.93	76	77	409			
				30.05	96	97	324			
			2	23.76	120	123	257			
				19.20	150	152	207			
				14.64	192	200	158			
				11.60	240	252	125			1700
1.50	4 (1725)	5.0/2.5	3	61.56	48	48	972	2500	min 15.75 max 78.74	
				46.23	60	63	730			
				37.93	76	77	599			
	2 (3450)	4.2/2.1	3	61.56	96	95	486			
				49.75	120	118	393			
				37.93	150	154	299			
				30.05	192	195	237			
			2	23.76	240	247	188			
				19.20	300	305	152			
				14.64	392	400	116			
				11.60	480	505	92			
				1700	9.43	600	621			74

Refer to page 59 for all footnotes cited on page 58.

# Motorized Pulley 165LS

Ø 6.50 in. (165 mm), with helical steel gearbox



Power & Speed Combinations: 3 phase									
Power HP	Poles (rpm)	FLA (amps) <sup>1</sup>	No. Gear Stages	Gear Ratio	Nominal belt speed at Full Load 60 Hz fpm <sup>2</sup>	Actual belt speed at Full Load 60 Hz fpm <sup>2</sup>	Belt Pull lbs	Max. Radial Load T1 + T2 lbs <sup>3</sup>	RL in
2.00	2 (3475)	5.7/2.8	3	75.03	76	75	815	2500	min 15.75 max 78.74
				61.56	96	96	658		
				46.23	120	128	494		
				37.93	150	156	405		
				30.05	192	196	321		
			2	23.76	240	248	254	1700	
				19.20	300	307	205		
				14.64	384	403	156		
				11.60	480	509	124		
				9.43	600	626	101		
7.80	768	757	83	1600					
3.00	2 (3460)	8.0/4.0	3	46.23	120	127	728	2500	min 16.93 max 78.74
				37.93	150	155	597		
				30.05	192	196	473		
				24.43	240	240	385		
				20.21	300	291	318		
			2	14.64	392	401	230	1700	
				11.60	480	506	183		
				9.43	600	623	148		
				7.80	768	753	123		
				7.80	768	753	123		

- 1 FLA = full load amps at 230volts and 460 volts, respectively.
- 2 Use "Nominal Speed" to specify pulley. "Actual belt speed" is presented (for unlagged pulley) to assist with process design calculations. See "Actual Speed vs Nominal Speed" section in Technical Precautions. Note that actual belt speed increases when lagging is used due to increased pulley diameter.
- 3 Pulley must not be subjected to radial load exceeding "Maximum Radial Load" defined above. See "Belt Tension" section in Technical Precautions.



# Motorized Pulley 165LS

Ø 6.50 in. (165 mm), with helical steel gearbox

## Spare Parts List and Sectional Drawings

1	Front shaft	53	Cable side nipple (cable option)	110	Screw
3	Rear flange	53.1	Nipple (terminal box)	111	Screw
5	Bearing housing complete w/geared rim	55	Spacer bushing	112	Socket set screw
7	Bearing housing rear side	56	Spacer bushing	113	Screw
8	Gearbox	63	Ball bearing	114	Socket set screw
10	Terminal box - bottom part	64	Needle bearing	115	Oil plug with magnet
11	Terminal box cover	65-70	Ball bearing	126	Key
12	Shell	73	Locking ring	127	Key
16	Rear shaft	74	Locking ring	131	Key
19	Input wheel	81	Locking ring	132	Key
20	Output pinion	85	Locking ring	136	O-ring/Rubber seal
22	Geared rim	86	Locking ring	138	Rubber seal
23	Intermediate pinion shaft	93	Elbow or straight connector	139	Grease nipple
24	Intermediate wheel	102	Screw		
31	Labyrinth seal cover	103	Screw		

## 165LS Standard: 2 stage gearbox with terminal box

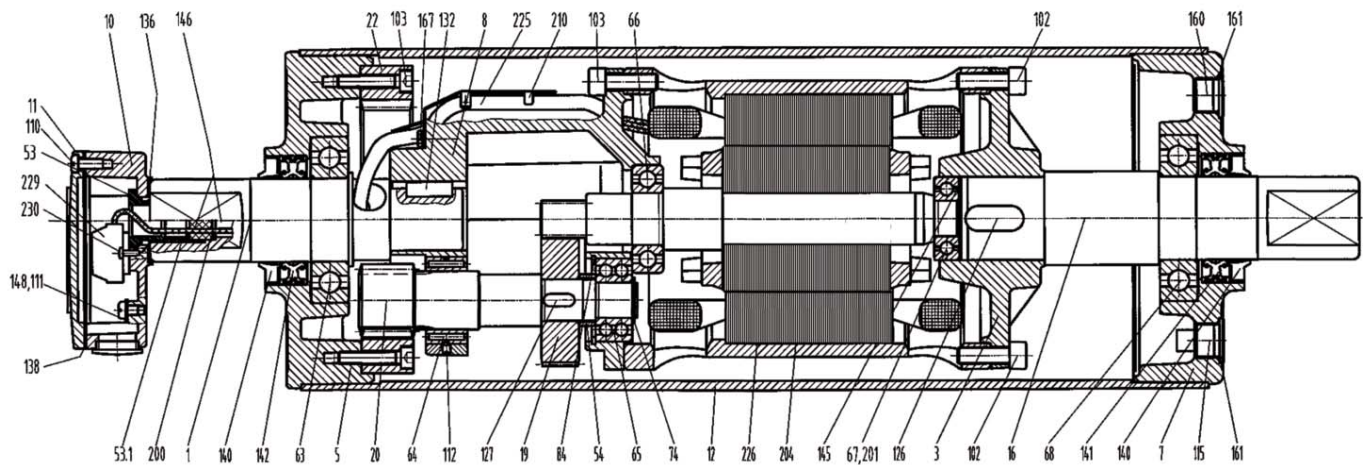

# Motorized Pulley 165LS

Ø 6.50 in. (165 mm), with helical steel gearbox



## Spare Parts List and Sectional Drawings (cont.)

140	Deflection seal	156	Rectifier (not shown)	208	Bearing housing w/labyrinth groove
141	Double lip seal	160	Oil plug	210	Fixing guard
142	Double lip seal	161	O-ring	225	Cable
143	O-ring	163	O-ring	226	Stator complete
145	Distance washer	167	Screw	229	WAGO clamp terminals
146	Washer	200	Rubber seal	230	Fixing bolts
148	Washer	201	Encoder (if applicable)	240	Distance ring
150	Electromagnetic brake	204	Rotor complete with pinion		
150.1	Friction disc	206	Insulated sleeve for wire protection		

**SS oil plug**

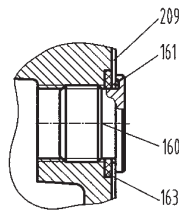

**Cable version with SS elbow connector**

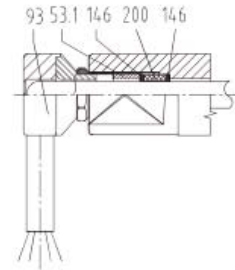

**Stainless steel version TS7N cable option with straight connector**

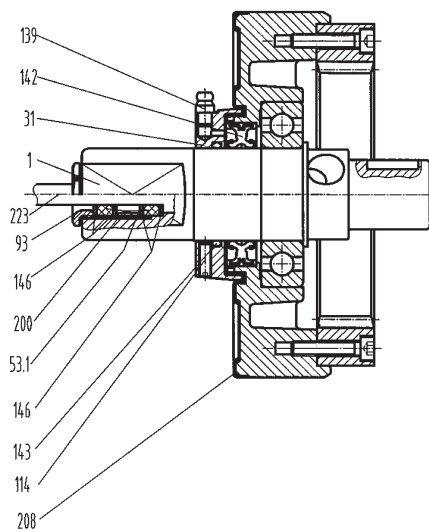

**3 stage gearbox**

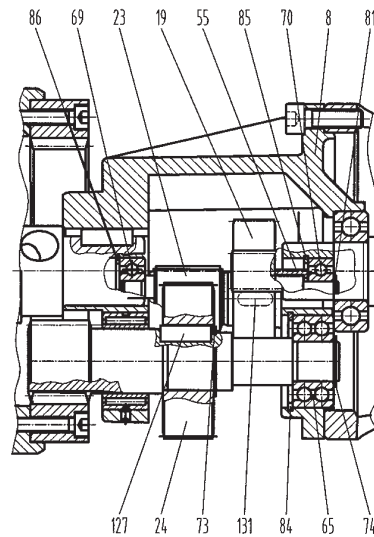

**Electromagnetic brake**

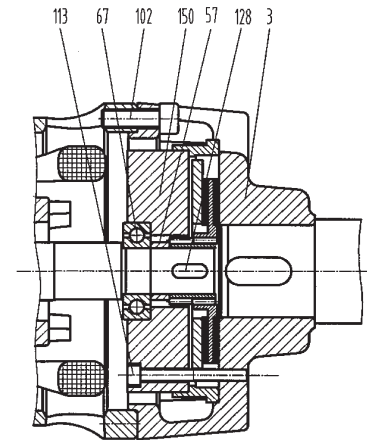





## **Optional Extras & Accessories**

<b>Mounting Brackets</b>	<b>65</b>
<b>Lagging for Standard Belts</b>	<b>66</b>
<b>Profiled Lagging &amp; Shells for Positive Drive Belts</b>	<b>68</b>
<b>Mechanical Backstops</b>	<b>71</b>
<b>Electromagnetic Brakes</b>	<b>72</b>
<b>Rectifiers for Electromagnetic Brakes</b>	<b>74</b>
<b>Encoders: SKF Bearing</b>	<b>75</b>
<b>Encoders: RLS Magnetic Shaft Encoder</b>	<b>77</b>
<b>Power Cords</b>	<b>79</b>



# Mounting Brackets for Motorized Pulley and Idler

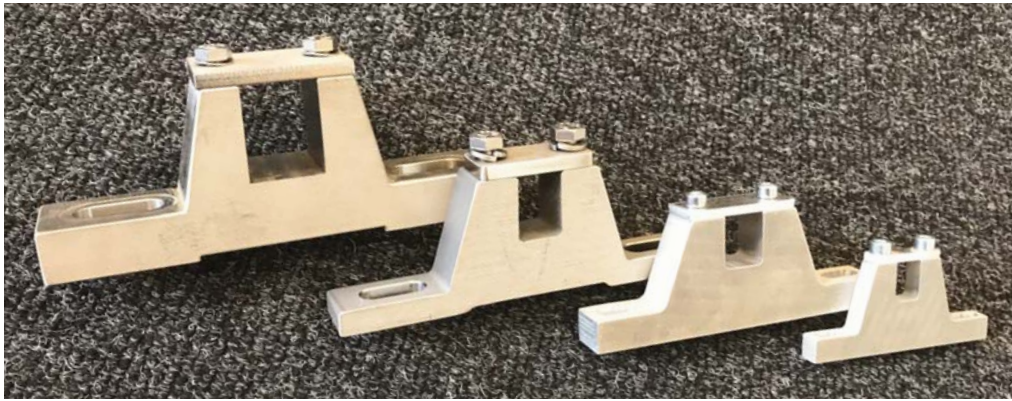

Mounting brackets: From left to right, 6YA0U (stainless steel for model 165LS), S2YAKA (stainless steel for model 138LS), S1MB03 (aluminum for model 113LS), and S0MB03 (aluminum for model 80LS)

**Dimensions, materials, and weights for Mounting Brackets**

Motorized Pulley	Standard Matl./ Part Number	Optional Matl./ Part Number	D [in]	F [in]	I [in]	K [in]	S [in]	T [in]	V [in]	W1 [in]	X [in]	X1 [in]	Z [in]	Z1 [in]	Thread	Weight [lbs]
80LS	Aluminum S0MB03	Stainless steel S0MB-US00SS	0.79	0.55	2.24	1.50	0.26	0.35	0.47	0.39	2.83	4.06	1.38	2.17	M6	0.3/0.5
113LS	Aluminum S1MB03	Stainless steel S1MB-US00SS	0.98	0.79	3.35	2.17	0.33	0.43	0.59	0.79	4.33	5.91	1.65	2.60	M6	1.1/2.0
138LS	Cast iron black paint S2YAKL	Stainless steel S2YAKA	1.18	0.79	3.39	2.24	0.43	0.67	0.47	0.94	4.33	7.09	1.75	2.83	M8	3.1
165LS	Cast iron black paint 6YA0K	Stainless steel 6YA0U	1.57	1.18	3.31	2.44	0.55	0.79	0.87	1.57	4.33	7.48	1.97	3.27	M8	4.4

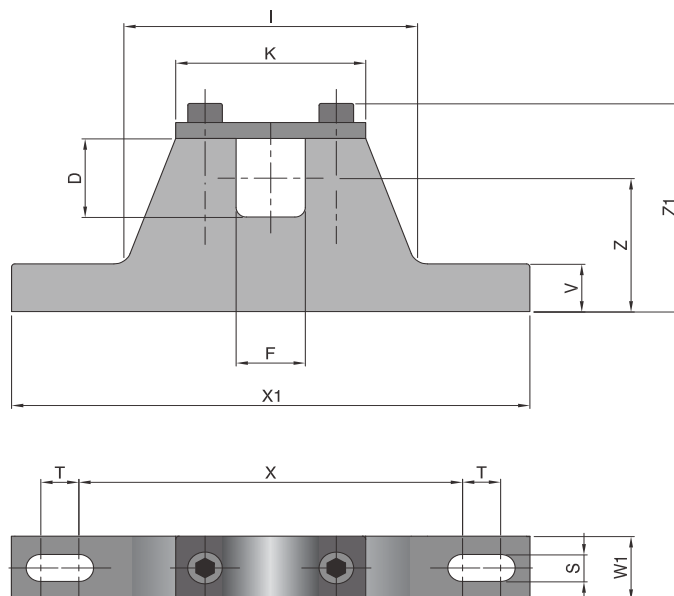



## Lagging for Standard Belts

Smooth or specially grooved lagging to increase friction between the shell and conveyor belt

### Product description

#### Characteristics

- High resistance to oil, fuel and other chemicals
- Increases friction between the shell of the Motorized Pulley and conveyor belt
- Prevents slip between the shell of the Motorized Pulley and conveyor belt
- Longitudinal grooved lagging reduces liquid build up between belt and shell
- Centered V-groove for belt tracking
- Multiple V-grooves for V-belt or round belt conveyors

#### Applications

- Wet applications
- For standard Motorized Pulleys
- Food and hygienic applications
- Flat belt, round belt or multi V-belt applications
- Hot vulcanization for high-torque Motorized Pulleys

**Note:** Lagging increases the outer diameter of the Motorized Pulley and increases its speed above that stated in the catalog. The belt pull and belt speed of the Motorized Pulley must be recalculated according to the increased diameter.

### Cold Vulcanized Lagging

Lagging profile	Color	Characteristics	Shore Hardness	Thickness (in)
Smooth	Black	Oil and Fat resistant	70 ± 5 Shore A	0.12, 0.20, 0.24, 0.31, 0.39, 0.47
	White	FDA food approved	70 ± 5 Shore A	
Longitudinal grooves	White	FDA food approved	70 ± 5 Shore A	0.31
Diamond Patterned	Black	Oil and Fat resistant	60 ± 5 Shore A	0.31

### Hot Vulcanized Lagging

Lagging profile	Color	Characteristics	Shore Hardness	Thickness (in)
Smooth	Black	Oil and Fat resistant	65 ± 5 Shore A	0.12, 0.20, 0.24, 0.31, 0.39, 0.47, 0.55
	White	FDA food approved	70 ± 5 Shore A	
	Blue	FDA food approved	70 ± 5 Shore A	
Longitudinal grooves	Black	Oil and Fat resistant	65 ± 5 Shore A	0.24, 0.31, 0.39, 0.47, 0.55
	White	FDA food approved	70 ± 5 Shore A	
	Blue	FDA food approved	70 ± 5 Shore A	
Diamond Patterned	Black	Oil and Fat resistant	65 ± 5 Shore A	0.24, 0.31



## Lagging for Standard Belts

Smooth or specially grooved lagging to increase friction between the shell and conveyor belt

### V-groove

#### Hot Vulcanization

A machined center groove in the hot vulcanized rubber lagging allows the use of conveyor belts manufactured with a tracking profile on the underside of the belt. Designed to help maintain tracking and to prevent belt wander. Conveyors using this type of belt should be designed so that the slider bed or roller bed primarily tracks the belt and not the Motorized Pulley.

#### V-groove lagging dimensions

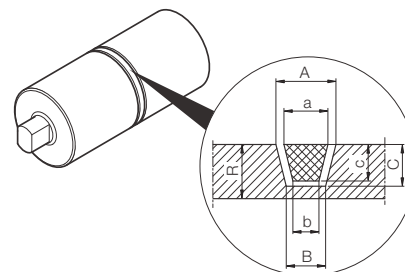

Lagging and V-groove dimensions							
Groove	Lagging R	Groove			Belt		
		A	B	C	a	b	c
K6	0.31	0.47	0.31	0.20	0.24	0.16	0.16
K8	0.35	0.55	0.39	0.28	0.31	0.20	0.20
K10	0.39	0.63	0.47	0.31	0.39	0.24	0.24
K13	0.47	0.75	0.55	0.39	0.51	0.30	0.31
K15	0.51	0.83	0.63	0.43	0.59	0.37	0.31
K17	0.59	0.91	0.71	0.51	0.67	0.37	0.43

All dimensions are expressed in inches.

Motorized Pulley Diameters with V-groove option				
Groove	80LS	113LS	138LS	165LS
K6	3.82	5.16	6.06	7.13
K8	3.90	5.24	6.14	7.20
K10	3.98	5.31	6.22	7.28
K13	4.13	5.47	6.38	7.44
K15	4.21	5.55	6.46	7.52
K17	4.37	5.71	6.61	7.68

All dimensions are expressed in inches.





## Profiled Lagging for Positive Drive Belts

Specially grooved lagging to drive segmented plastic and smooth continuous positive drive belts

### Product description

#### Characteristics

- Resistance to abrasion
- Low noise during operation
- Reduced belt wear
- Easy to clean
- High resistance to oil, grease, and chemicals

#### Applications

- Applications for food environments
- Profiles to suit most manufacturers' positive drive belts.

**Note:** Lagging increases the outer diameter of the Motorized Pulley and increases its speed above that stated in the catalog. Belt pull and speed of the Motorized Pulley must be recalculated according to the increased diameter.

### Technical data

<b>Material</b>	Hot vulcanized nitrile rubber NBR
<b>Shore Hardness</b>	From 65 to 70 ± 5 Shore A

Plastic modular belt manufacturer	Series	Number of teeth			
		80LS	113LS	138LS	165LS
Intralox	800		9	10	12
	1600	13	16	20	23
	1100 FT PE/AC		27		
	1100 FT PP	20	27	32	38
Siegling	LM50 Series 3		9	10	
Uni Chains / Ammeraal	CNB		16	20	
	MPB		9	10	
	S-MPB	12	16	20	

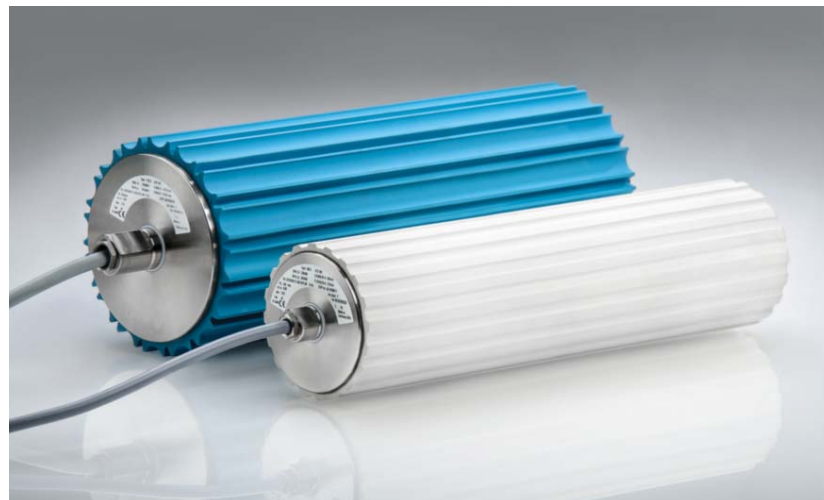

## Profiled Shells for Positive Drive Belts

Specially grooved pulley shells to drive segmented plastic and smooth continuous positive drive belts

### Product description

#### Characteristics

- Stainless steel shells are CNC machined for excellent fitting accuracy and corrosion resistance
- Other shell materials (e.g. acetal) offer low friction
- Cylindrical shells with welded keys for drive sprockets are also available

#### Applications

- Applications for food environments
- Profiles to suit most manufacturers' positive drive belts.

**Note:** Profiled pulley shells are thicker than standard shells. They increase the outer diameter of the Motorized Pulley and increase its speed above that stated in the catalog. Belt pull and speed of the Motorized Pulley must be recalculated according to the increased diameter.

### Ordering Information

Different belt designs and materials may affect the operational characteristics. Please answer the following questions and send them to Rulmeca with your inquiry (also see ordering information sheet on page 9).

- Preferred shell material (e.g. SS, acetal, etc)
- Thermoplastic non-modular belt or plastic modular belt
- Motorized Pulley diameter
- Required belt speed
- Belt manufacturer
- Belt series
- Belt type and variant
- Belt material
- Number of teeth
- Tooth Pitch
- Reversible, yes or no
- Outside diameter (D) in inches
- Pitch circle diameter (PCD) in inches



Top: Stainless steel shells profiled to drive smooth continuous positive drive belt

Bottom: Profiled acetal sleeve keyed onto stainless steel shell to drive positive drive belt



## Profiled Shells for Positive Drive Belts

Specially grooved pulley shells to drive segmented plastic and smooth continuous positive drive belts



Top: Profiled stainless steel pulley shell to drive plastic segmented belt

Center: Profiled stainless steel pulley shell to drive smooth continuous positive drive belt

Bottom: Profiled stainless steel shell to drive four T10 belts

## Product Description

### Characteristics

- The backstop runs only in one direction
- Mounted on the rotor shaft, except for the 80LS
- Mounted in the end housing on the 80LS
- No need for an electrical connection

### Application

- Single direction inclined belt conveyors
- For preventing roll-back of the belt and load when the power supply is off

The rotational direction of the motorized pulley with backstop is indicated by an arrow on the end housing on the electrical connection side.

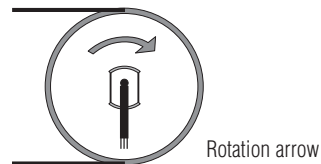

## Product range

Rotation direction from the electrical connector side	Clockwise Counterclockwise
---	-------------------------------

## Product description

### Characteristics

- Low noise
- Wear contained
- Powered by a separate external rectifier
- Applied directly on the rotor of the Motorized Pulley
- When the power to the motor is lost or stopped the brake will close (mechanically engage)

### Applications

- For reversible inclined and declined conveyors
- For holding loads\*
- For approximate positioning

\* For faster stopping times and accurate positioning, please use a variable frequency drive with braking function and, if necessary, an encoder with feedback control.

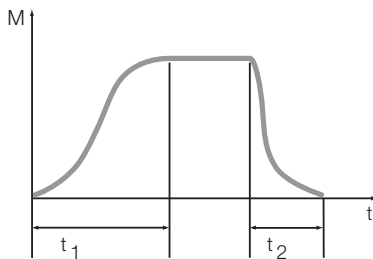

**Fig.: Time t/Torque M brake closure**

- t<sub>1</sub>** Closing response time (de-excitation coil): stop  
**t<sub>2</sub>** Opening response time (excitation coil): start

### Response time

The response time for opening of the brake (Motorized Pulley start) and closing (stop motorized pulley), may vary substantially according to:

- Type and viscosity of the oil
- Level of oil in the drum motor
- Ambient temperature
- Internal motor working temperature
- Switching at input (AC-switching) or at output (DC-switching)
- Control contact of the coil brake into the alternating current supply of the rectifier (long response times), or on the output DC of the rectifier (fast response)
- Type and output voltage of the rectifier control of the brake coil

The difference between the control in alternating current and direct current is shown in the following table:

	AC Switching	DC Switching
Intervention time	Slow	Fast
Braking voltage	Nearly 1Volt	Nearly 500volt

**Note:** For the brake coil command in DC, the contacts must be protected against surges.

### Reduction of braking torque

The rated brake holding torque M, is strongly influenced by the operating conditions of the Motorized Pulley (with oil at high temperatures) and the ambient temperature. To conservatively calculate the load which can be safely held by the brake, reduce the braking torque presented in the table by 50%.



# Electromagnetic Brakes



Product range							
Motorized Pulley	Rated holding torque M (ft-lbs)	Rated power (W)	Rated voltage (VDC)	Rated current (A)	DC switching t1 (ms)	AC switching t1 (ms)	Opening delay time t2 (start) (ms)
80LS	0.81	12	24	0.5	13	80	20
			104	0.12	13	80	20
113LS 138LS	4.43	24	24	1.00	26	200	30
			104	0.23	26	200	30
			207	0.12	26	200	30
165LS	8.85	33	24	1.38	46	260	40
			104	0.32	46	260	40
			207	0.16	46	260	40



# Rectifiers for Electromagnetic Brakes

## Product description

### Characteristics

- The Rectifier for the electromagnetic brake is an external component and must be installed in a protective box, as close as possible to the Motorized Pulley.
- The fast-acting rectifier starting output voltage equals  $0.9 \times$  input AC voltage for 0.004 seconds to 2 seconds, depending on the external resistance. The fast-acting rectifier holding output voltage equals  $0.45 \times$  input AC voltage.

### Applications

- Motorized pulleys with electromagnetic brake

Product range					
Part number	Input Voltage to Motorized Pulley VAC	Input Voltage to Brake VDC	Rectifier Output Starting Voltage VDC	Rectifier Output Holding Voltage* VDC	Rectifier type
SW4B0A	230	104	207	104	Fast-acting rectifier
SW4BED	460	207	414	207	Fast-acting rectifier

\*Using a fast-acting rectifier will save energy and reduce brake coil heat. These types of rectifiers generate a holding voltage lower than the starting voltage of the brake coil itself.

## Product description

### Characteristics

- Supplies low resolution signals to an external control unit
- Embedded in the rotor bearing
- Cannot be combined with the electromagnetic brake option

### Application

- For applications which require the continuous control of the speed, direction, and position of the Motorized Pulley belt or load



### Technical data

<b>Rated voltage</b>	From 5 to 24 VDC
<b>Max. operated current</b>	From 8 to 10 mA
<b>Max. output current</b>	20 mA
<b>High level voltage</b>	> 3.5 V
<b>Low level voltage</b>	<0.1 V

### INC resolution

The INC resolution (number of increments per pulley revolution) depends on encoder type and can be calculated as follows:

$$INC = Z \times i$$

- i** Gear ratio of the Motorized Pulley (except for model 80LS). Gear ratio of 80LS equals one because encoder is mounted on end housing and not on motor rotor.
- Z** Number of encoder increments per rotor revolution

### Product range

Motorized Pulley	Bearing type	Increments per rotor revolution
from 80LS to 138LS	6202	32
165LS	6205	48

**Note:** The Motorized Pulley 80LS with encoder has 2 cables-one exiting through each shaft at either end.

## Control interface

The encoder has open collector NPN transistor outputs. When connected to the input of a control interface the required load resistances (R) have to be used. The load resistances are stated in the table below. When using different interfaces or when you have any doubts, please contact Rulmeca or a local electronic specialist.

Rulmeca recommends the use of an Opto-coupler for the following reasons:

- To protect the encoder
- To enable connection to other levels such as PNP
- To get the maximum potential between high and low signal

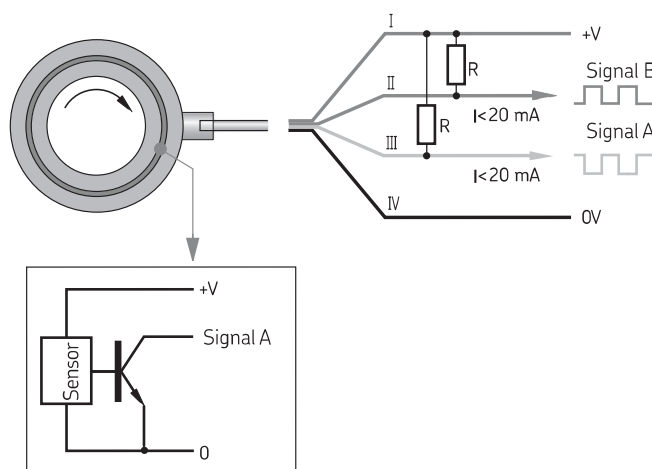

Voltage +VDC	Load Resistances R (ohms)
5	270
9	470
12	680
24	1500

## Product description

### Characteristics

- Supplies high resolution signals to an external decoder and control unit
- Embedded in the rotor bearing
- Cannot be combined with an electromagnetic brake

### Applications

- For applications which require control of speed, direction, and position of the Motorized Pulley belt or load



### Technical data

<b>Power supply</b>	$V_{dd} = 5\text{ V} \pm 5\%$
<b>Power consumption</b>	35 mA
<b>Output signals</b>	A, B, Z, A-, B-, Z- (RS422A)
<b>Max cable length</b>	16.40 ft
<b>Operating temperature</b>	-13 °F to +185 °F
<b>Ext. operat. temp.</b>	-40 °F to +257 °F (IP64)
<b>Edge separation</b>	1 $\mu\text{s}$ minimum

### The INC resolution

The INC resolution (number of increments per pulley revolution) depends on encoder type and can be calculated as follows:

$$\text{INC} = Z \times i$$

- i** Gear ratio of the Motorized Pulley (except for model 80LS). Gear ratio of 80LS equals one because encoder is mounted on end housing and not on motor rotor.
- Z** Number of encoder increments per rotor revolution

### Product range

Motorized Pulley	Encoder type	Rated voltage VDC	Max. operating current mA	Increments per rotor revolution p	Max. cable length ft	Precision °
80LS - 165LS	RS422A 5V	5	50	1024	16.4	0.5

**Note:** Other resolutions are available on request.

## Timing diagram

(complementary signals not shown)

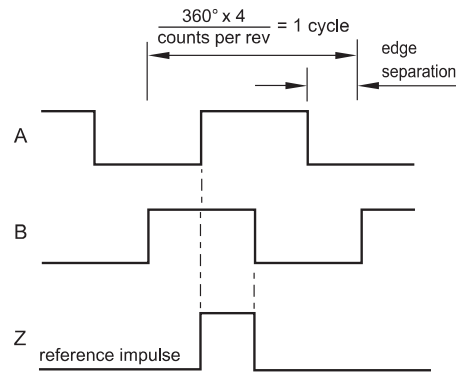

B leads A for clockwise rotation of magnetic actuator.

## Recommended signal termination

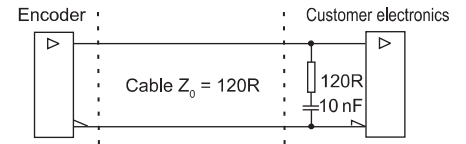

## Data sheet

### RM44D01\_04

### RM44IC - Incremental, RS422A, 5V

Resolution options (increments per rev)	Maximum speed (rpm)	Accuracy	Hysteresis
1024	20000	$\pm 0.5^\circ$	0.18°
4096	5000	$\pm 0.5^\circ$	0.18°

\* Worst case within operational parameters including magnet position and temperature.

Connections		
Pin Nr.	Function	Wire color
1	Shield	-
2	Z	White
3	B	Green
4	A	Grey
5	$V_{dd}$	Red
6	Z-	Brown
7	B-	Yellow
8	A-	Pink
9	GND	Blue

## Product description

### Characteristics

- Power cords are a robust space-saving alternative to terminal box

### Applications

- For applications where space is severely restricted



Standard power cord with stainless steel straight connector



Standard power cord and encoder data cord with stainless steel straight connector

Model	80LS	113LS - 138LS	165LS	113LS - 138LS	165LS	80LS-113LS	80LS-113LS
Option	Standard	Standard	Standard	Brake	Brake	RLS Encoder	SKF Encoder
<b>Power Cord</b>							
No. of wires	7	7	7	9	9	7	7
Wire gage	20	19	16	19	16	20	20
Wire identification	numeric	numeric	numeric	numeric	numeric	numeric	numeric
Wire insulation material	PVC	PVC	PVC	PVC	PVC	TPE	TPE
Color of outer sheath	gray	gray	gray	gray	gray	orange	orange
Screen material	copper	copper	copper	copper	copper	copper	copper
Outer diameter of cord (in)	0.26	0.31	0.39	0.41	0.51	0.26	0.27
Operating voltage (V)	300/500	300/500	300/500	300/500	300/500	300/500	300/500
Operating voltage per UL (V)	600	600	600	600	600	600	600
Temperature range (°F)	+23 to +158	+23 to +158	+23 to +158	+23 to +158	+23 to +158	+23 to +158	+23 to +158
Temperature range per UL (°F)	+23 to +194	+23 to +194	+23 to +194	+23 to +194	+23 to +194	+23 to +194	+23 to +194
Approval	UL/CSA	UL/CSA	UL/CSA	UL/CSA	UL/CSA	UL/CSA	UL/CSA
<b>Data Cord</b>							
No. of wires						9	4
Wire gage						22	22
Wire identification						color code	color code
Cord insulation material						PVC	PVC
Outer diameter of cord (in)						0.21	0.19









## Environmental Conditions

### Hygienic conditions

For food processing and other applications where hygiene is important, we recommend the following materials, connectors and accessories:

- Stainless steel shell
- Stainless steel shaft
- Stainless steel end housings
- IP69 sealing
- Hot vulcanized Lagging, FDA approved and/or oil and fat resistant
- Oil, food-grade, synthetic
- Stainless steel terminal box or straight or elbow connectors in stainless steel
- Diamond patterned lagging is not suitable for food processing because it is difficult to clean and can leave traces of bacteria

### Conveyor frame

According to EHEDG design rules, it is highly recommended to incorporate rust-free open conveyor frames to facilitate easy cleaning, wash down, and disinfection of the conveyor, Motorized Pulley, and belt. The rubber material shall be USDA/FDA and EC1935/2004 compliant.

### Altitude higher than 3,300 ft

The operation of a Motorized Pulley at an altitude above 3,300 ft above sea level may result in a loss of power and overheating due to low atmospheric pressure and the lower density of the air, which cools the motor. The altitude of the final application should be taken into consideration when calculating the required power. For more information please contact Rulmeca.

### Wet and washdown applications

Wet and washdown applications require stainless steel materials for the Motorized Pulley shell and sealing system.

The following materials and accessories are available:

- Stainless steel shell with hot vulcanized lagging (if necessary)
- Stainless steel shaft
- Stainless steel end housing
- IP69 sealing
- Lagging, all types are possible
- Diamond patterned lagging can be used for non-food wet applications
- Cable connectors, all types are possible
- For IP69 sealing option, limit high pressure wash down at various angles to a maximum of 2,150 psi at +176°F at 6 inches from Motorized Pulley for 30 seconds.

### Dry and dusty applications

All standard Rulmeca Motorized Pulleys, regardless of specification or material, are sealed to IP66 protection rating. For applications in hazardous areas requiring intrinsically safe or explosion-proof motors, please contact Rulmeca.

## Low temperature

In ambient temperatures below  $-20^{\circ}$  F, consider heating the motor windings to keep the oil, seals, and internal parts at a constant temperature. If the motor current is switched off for an extended period of time when the ambient temperature is very low, the motor oil viscosity increases. It is also possible that ice crystals could form within the oil seals and cause premature seal wear. In this situation, select anti-condensation heating system (e.g. trickle voltage through motor.) Contact Rulmeca for additional information.

When a Motorized Pulley is operated in low temperatures (less than  $+40^{\circ}$  F), the viscosity of the oil and temperature of the motor when it is not running should be considered. Consider also that condensation inside the Motorized Pulley and terminal box may occur with varying wide ranging temperatures. Also note that very low temperatures reduce the effectiveness of rubber lagging to increase friction.

We recommend the use of the following materials, cables and accessories:

- Stainless steel shell
- Stainless steel shaft
- Stainless steel end housing
- IP69 sealing
- Optional special oils for low temperatures
- Anti-condensation internal heating
- Lagging, all types are possible
- Cable connections, all kinds are possible



# Technical Precautions for Design, Installation and Maintenance

Read and follow all safety instructions! These instructions contain important sections on design, installation, safety, use, maintenance, parts replacement, and other technical information. Always include these instructions with pulley.

Read the manual before installing or operating the pulley. Failure to understand how to install or operate the pulley could cause personal injury or even death. Any modification made to or unintended use of the pulley could create a hazardous condition that could cause death or serious injury.

## Contents

	<b>Page</b>
Actual Belt Speed vs, Nominal Belt Speed.....	85
Aftermarket Service.....	85
Ambient Temperature.....	85
Belt Alignment.....	85
Belt Pull.....	85
Belt Tension.....	85
Capacitors for Single Phase Motors.....	86
Clearance.....	86
Electric Installation.....	86
Electromagnetic Brake.....	86
Guarding & Lock Out/Tag Out.....	86
High Duty Cycle.....	86
Lagging Description.....	87
Mechanical Backstops.....	87
Motor Current Overload & Overcurrent Protection.....	87
Motor Thermal Protection.....	87
Motorized Pulley Mounting Orientation.....	87
Mounting Brackets.....	88
Non-Belt, Partial Belt, Modular Belt.....	88
Oil & Oil Seal Maintenance.....	88
Pulley Diameter.....	88
Regreasable Labyrinth Seals.....	89
Reversing Conveyors.....	89
Surface Coating.....	89
Storage of Motorized Pulleys.....	89
Start-up.....	89
Terminal Box.....	89
Transport & Handling.....	90
Variable Frequency Drive.....	90

## IMPORTANT INFORMATION

- After unpacking the pulley, inspect carefully for any damage that may have occurred during transit. Check to be sure all supplied accessories are enclosed with the unit. If you have questions regarding safety or damaged or missing parts, please contact RULMECA.
- Also, for testing the pulley, shafts must be fixed to a frame properly before motor is connected to the power supply and switched on. The shell must be protected against accidental contact because of rotating.
- It is the responsibility of the contractor, installer, owner and user to install, maintain and operate the conveyor, components and conveyor assemblies in such a manner as to comply with: The Occupational Safety and Health Act and with any and all state and local laws and ordinances as to the national and international standards:
  - ANSI – B20.1 Safety Code and Conveyor Equipment Manufacturers Association (CEMA) voluntary consensus standards which may prevail,
  - ANSI – Z535 Warning label Series
  - ISO 3864-2 Product Safety labels
- When existing equipment is being retrofitted, upgraded or even changed, it is in the customer's best interest to bring the equipment up to today's standards. If there are any questions, please contact RULMECA.

*Do not install standard drum motors in areas with potentially explosive concentrations of vapors, gases, mists and dust.*

# Technical Precautions for Design, Installation and Maintenance



## 1) Actual Belt Speed vs. Nominal Belt Speed:

- Two key specifications for each Motorized Pulley are power (HP) and nominal belt speed, as shown on individual specification pages in this catalog.
- Nominal belt speed is a design target, providing consistent choices among all models and powers. For example, a nominal belt speed of 300 fpm is available in most pulley models.
- Actual full load belt speed is almost never exactly equal to nominal belt speed.
- Actual belt speed is a function of the motor pole number, gear ratio, and load. Therefore, this catalog displays actual full load belt speed at 60 Hz, as well as nominal belt speed, to assist designers who need more precise belt speeds.
- Note that all belt speeds shown in this catalog refer to unlagged pulleys, as described in the speed chart footnote for each model.
- Note that each Rulmeca Motorized Pulley for a three-phase power supply uses an asynchronous squirrel-cage induction motor with approximately 5% slip. In a no load condition, motor RPM is nearly equal to “synchronous speed” RPM. The slip rate is dependent on power and design of the motor. Low-powered motors have a lower slip rate than high-powered motors. At full load, the motor RPM is approximately 5% less than synchronous.
- The “actual belt speed” displayed in this catalog is based on an unlagged pulley running at full load, nominal voltage (e.g. 460 volts), and 60 Hz.
- The maximum no load belt speed of this pulley is approximately 5% higher than the full load belt speed.

## 2) Aftermarket Service:

- Always contact your local authorized Rulmeca service center or distributor for aftermarket service.
- You may also contact Rulmeca at [www.rulmecacorp.com](http://www.rulmecacorp.com).

## 3) Ambient Temperature:

- Motorized Pulleys are normally cooled by dissipating heat through contact between the surface of the pulley and the conveyor belt. It is essential that each pulley have an adequate thermal gradient between the pulley's motor stator and its “ambient operating temperature”.
- All Motorized Pulleys in the catalog are designed and tested under full load for use in a maximum ambient temperature of +104°F with standard Class F motor. Motorized Pulleys with Class H motors and synthetic oil are suitable for use in a maximum ambient temperature of 120°F.
- For example, a conveyor belt in a facility with an air ambient temperature of +75°F, carrying processed material at a temperature of +130°F, will have a Motorized Pulley “ambient operating temperature” that is significantly higher than +75°F. In this example, the actual temperature of the bottom of the belt in the vicinity of the Motorized Pulley may be equal to the material temperature, depending upon parameters such as conveyor length, belt thickness and belt speed.
- In retrofit applications it is advisable to measure the temperature of the underside of the belt near the the drive pulley to determine the actual “ambient operating temperature”.
- For ambient operation conditions lower or higher than allowable ambient temperature (-22°F to 120°F), contact Rulmeca.

- All Motorized Pulleys shown in this catalog must be fitted with a conveyor belt to prevent overheating. Motorized Pulleys fitted without a belt must be referred to Rulmeca.
- It is possible to use specially designed Motorized Pulleys to perform tasks other than driving standard rubber conveyor belt (e.g. modular plastic belts and v-belts. Please contact Rulmeca for such applications.
- Operating Rulmeca Motorized Pulleys to drive standard conveyor belts outside of the allowable ambient temperature range *voids product warranty*.

## 4) Belt Alignment:

- Motorized Pulleys must be installed with pulley shaft perpendicular to belt centerline and parallel to all idler rollers.
- Belt centerline must be straight and parallel to side walls of slider bed (if any) and perpendicular to idler rollers and all pulleys.
- Belt and/or roller misalignment may cause high friction and overload the conveyor belt drive motor.
- Belt misalignment may cause premature wear of pulley lagging.

## 5) Belt Pull:

- This catalog specifies “Actual Belt Pull” for each model, power, and speed of pulley. Note that the specified actual belt pull allows for a motor and gearbox efficiency loss of 3 to 5%.
- Always select the Motorized Pulley power by comparing calculated “Required Belt Pull (Te)” with “Actual Belt Pull” as listed in this catalog and not simply on the basis of calculated power (HP).

## 6) Belt Tension:

- The conveyor should never be over-tensioned. It should only be installed with sufficient belt tension to prevent belt slippage.
- Anti-slip lagging should be used to keep the radial load as low as possible to drive the belt without slipping.
- The maximum allowable radial load of each Motorized Pulley is specified in this catalog. Subjecting the Motorized Pulley to a higher than specified maximum radial load may damage internal components and shorten product lifetime and, therefore, *voids product warranty*.
- To check the pulley radial load, do a vector summation of the loads on the pulley.
- For example, as shown in the diagram,
  1. Radial load equals  $T_1 + T_2$ .
  2.  $T_1$ , tight side tension, equals Belt Pull (Te) plus  $T_2$ .
  3.  $T_2$ , slack side tension, is determined using CEMA standard calculations or DIN 22101 to provide enough friction between the pulley and the belt to drive the belt and limit the belt sag between idlers.
- Belt type, belt thickness and minimum allowable pulley diameter must be selected according to Belt Supplier Requirements.

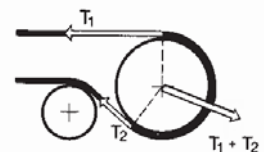



# Technical Precautions for Design, Installation and Maintenance

## 7) Capacitors (for Single Phase Motors):

- Each single phase Motorized Pulley requires an appropriate "Run" capacitor, ordered separately. Detailed information is available upon request.
- Using other than the specified Run capacitor and a current-dependent switching relay may damage the motor and *voids product warranty*.
- The Run capacitor must be permanently connected to the motor, as shown in the connection diagram.
- Rulmecca single phase motors are "permanent split phase motors". Each motor is supplied with two windings. They are designed so that an appropriately sized capacitor connected to one of the windings will start the motor rotating.
- Starting torque is limited to 70% of full running torque when only a "Run" capacitor is used.
- It is possible to increase starting torque to 100% by adding a second appropriately sized capacitor ("Start" capacitor) to the circuit. Note that this circuit must be designed to drop the starting capacitor out of the circuit after the motor has reached its nominal speed. Contact Rulmecca for more information on how to run single phase motors using the Start and Run capacitors.

## 8) Clearance:

- It is necessary to design conveyor frame and all chutes such that structure and/or product jamming against the Motorized Pulley is avoided.
- The "non-rotating shaft" feature of Motorized Pulleys offers a higher margin of safety than exposed drives with rotating shafts. However, Motorized Pulley end housings, lagging or tube may be damaged if structure or product jams against pulley while it is rotating.

## 9) Electrical Installation:

- The equipment manufacturer (OEM) must ensure that the Motorized Pulley is not put into operation before it is
  - Correctly installed
  - Correctly connected to the power supply
  - Correctly protected
- A specialist must perform the electrical connection of the Motorized Pulley in accordance with electrical regulations. If in doubt, contact Rulmecca.
- A wiring diagram is always supplied with the Motorized Pulley. Always refer to the connection instructions and ensure that the motor power and control circuits are properly connected.
- Standard Rulmecca Motorized Pulleys are delivered with clockwise rotation when viewed from the terminal box end of the Motorized Pulley.
- Always refer to the connection instructions and ensure that the motor is connected as required to the correct power supply.
- Connect system ground wire to grounding screw located in the terminal box.
- When using cable options, the green/yellow wire must be connected to the system ground wire.

## 10) Electromagnetic Brake:

- The spring-loaded electromagnetic brake is intended for use as a conveyor belt holding device and not a conveyor belt stopping device.
- The control circuit for the Motorized Pulley motor and brake must be designed to stop the pulley motor before brake clamps shut and start the pulley motor after the brake is released.
- Spring-loaded electromagnetic brakes are designed to release when power is applied to the brake coil. This is a "fail safe" feature. They clamp shut when brake power is removed (either during normal operation or during an emergency loss of overall system power).
- Control circuit must be designed so that motor and brake never work against each other. The brake should never be clamped shut when the motor is on except for "emergency stop" condition. The motor should never be powered on (including "jog" command) when the brake is clamped shut.
- Electromagnetic brakes are DC-powered. They are supplied with AC to DC rectifiers to be mounted in a remote panel (by others). Rectifiers must be fuse-protected.
- Motor control circuit must be designed to kill motor power in the event of loss of brake power. If this safety provision is not made, it is possible for pulley motor to be "powered through" a clamped brake, ruining brake and/or motor.
- A wiring diagram is supplied with every Motorized Pulley. Always ensure that motor and brake power and control circuits are connected according to instructions. Wiring diagrams are available separately, at any time, upon request.
- For rectifier connection and protection instructions, refer to rectifier data sheet supplied with Motorized Pulley.
- The built-in brake disc is a wear part. Its lifetime depends on the operating conditions.
- Neglecting these instructions could cause damage to the motor and/or brake and *voids product warranty*.

## 11) Guarding and Lock Out/Tag Out:

- If repair or maintenance is required, the Motorized Pulley must be disconnected from the power supply before the terminal box can be opened. Turn the electrical power off at the electrical panel board (circuit breaker or fuse box) and lock and tag the panel board door to prevent someone from turning on power while unit is being serviced. Failure to do so could result in serious electrical shock, burn, or possible death.
- During a test run, the shaft ends must be correctly fixed to the support frame and guarding must be provided around the rotating parts for the protection of all personnel.

**WARNING:** *DO NOT operate without guards in place. Failure to follow these instructions could result in death or serious injury.*

## 12) High Duty Cycle:

- Rulmecca Motorized Pulleys are designed to operate either continuously or intermittently. The table below gives each standard model's maximum allowable start/stop duty cycle for intermittent operation. Operating Motorized Pulley above this maximum could cause motor and/or gearbox damage and *voids product warranty*.

# Technical Precautions for Design, Installation and Maintenance



Maximum Number of Start/Stops per Minute		
Model	3 phase	1 phase
80LP, 80LS, 113LP, 113LS	15	10
138LS	4	Contact Rulmeca
165LS	3	Contact Rulmeca

- Optional Motorized Pulley designs are available to operate at higher duty cycles working with soft start devices or appropriately programmed Variable Frequency Drives. Contact Rulmeca before designing a system to operate at a duty cycle higher than specified in this catalog.
- Note that a conveyor control system that incorporates a “jog” command should be timed to restrict the number of jogs to the maximum allowable start/stop duty cycle for each pulley model.

### 13) Lagging Description:

- Smooth, diamond pattern, and profiled lagging is available in different colors. Approximate rubber hardness is 65-70 durometer (shore hardness A).
- Cold bonded or hot vulcanized lagging is available.
- Oil & grease resistant synthetic rubber is also available for oily operating conditions and/or certain types of belting material. Check with belting supplier if belt/lagging material compatibility could be a problem.
- Adequate Motorized Pulley heat dissipation is necessary. Lagging thickness and width greatly effect pulley heat dissipation characteristics.
- Contact Rulmeca before applying any lagging to pulley surface to obtain thickness and width specifications and *maintain Motorized Pulley warranty coverage*.
- Lagging material is a wear item and should be replaced when it wears out. Service life depends upon the application. *Product warranty does not include lagging wear*.
- Rulmeca Motorized Pulleys shown in this catalog must be fitted with a conveyor belt to prevent overheating. Motorized Pulleys fitted without a belt must be referred to Rulmeca.

### 14) Mechanical Backstops:

- Motorized Pulleys fitted with mechanical backstops are used on inclined conveyors to prevent run back of the loaded belt when power supply is off.
- The backstop is built into the Motorized Pulley and mounted on the rotor shaft.
- If pulley is supplied with optional mechanical backstop, direction of proper rotation of pulley is indicated by an arrow which is fastened to the end housing on the terminal box (or power cord) side of the pulley. Clockwise and counterclockwise backstops are available.
- Rotation direction is to be specified when placing the order.
- Pulley rotation is specified from the point of view of a person looking at the pulley from the terminal box (or power cord) side of the pulley.
- The identity of each of the three phases of the power supply must be determined before attaching power supply wires to the pulley to prevent the motor from driving against the backstop. The identities of the three phases of the motor are clearly labeled on the terminal strip or wires (in power cord type).
- Driving the motor against the mechanical backstop may damage motor and/or backstop and *voids product warranty*.

### 15) Motor Current Overload and Overcurrent Protection:

- Motor control system must include protection against operating pulley motors in excess of Full Load Amperage (FLA). The control system should also include protection against voltage spikes and excessive jogging of motors. Failing to provide adequate current overload and over current protection could stress the motor and *voids product warranty*.
- Electrical connection diagrams for many models are included in this catalog. Connection diagrams for all other models are available upon request.
- FLA data is available for all motors upon request. FLA data is also supplied on motor label for each Motorized Pulley.
- Electrical power, control, and protection for Motorized Pulleys must adhere to all pertinent regulations.

### 16) Motor Thermal Protection:

- All Motorized Pulleys are supplied with thermal protection. It consists of heat-sensitive, bimetallic switches that are built into each motor winding. The switches are designed to open if motor temperature elevates to an inappropriately high level. Standard Rulmeca thermal switch has a maximum current limit of 2.5 amps at 230 volts. Other thermal switches are available.
- Switches in three phase motors must be connected to a normally closed control circuit (in series with a magnetic coil/relay device and contactor) in order to *validate product warranty*.
- Switches in certain single phase motors are installed in series with motor winding. These switches can deactivate and re-energize motors automatically.
- A motor control circuit for three phase Motorized Pulleys should kill motor power if thermal switch opens. Thermal switches will automatically close as motor cools. Cooling times vary with pulley model, power, and size. However, 30 to 60 minutes is common with most motors in an ambient temperature of 70° F.

### 17) Motorized Pulley Mounting Orientation:

- Rulmeca Motorized Pulleys should always be mounted with pulley shafts horizontal, parallel to idler rollers, and perpendicular to conveyor centerline.
- Motorized Pulleys are positioned such that the mounting brackets are located parallel or perpendicular to the conveyor frame. If Motorized Pulley needs to be mounted to the bottom of a horizontal beam, contact Rulmeca.
- For Motorized Pulley types 80LP - 165LS “UP” is indicated with the word “UP” stamped on the pulley shaft.

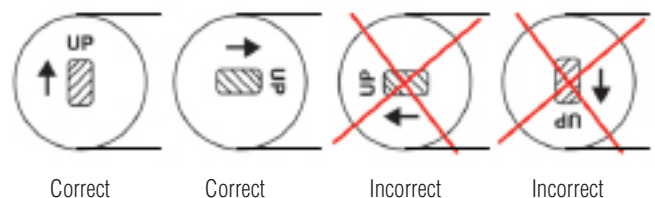

- Models 80LP - 165LS are to be mounted as shown on the sketch above.
- *In case of a non-horizontal installation > +/-5 degrees, consult Rulmeca.*
- Mounting the Motorized Pulley in a position other than those described above could cause severe product damage and *voids product warranty*.



# Technical Precautions for Design, Installation and Maintenance

## 18) Mounting Brackets:

- Use the correct Rulmecca mounting brackets matching the respective types of Motorized Pulleys as listed in this catalog.
- Note that it is physically possible, but not permissible, to interchange mounting brackets between models. Mounting brackets designed for smaller diameters or lower-powered pulleys may not be used for larger diameters or higher-powered pulleys.
- Mounting brackets must be mounted to frame such that belt pull is resisted by the shoulder or base of the mounting bracket. Mounting brackets have a top shaft retaining plate. This plate is not designed to resist belt pull.

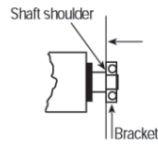
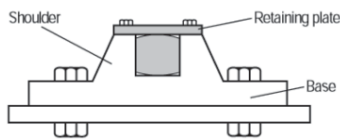

- The designer must select appropriate mounting bolts to resist belt forces and/or the weight of the pulley depending on the mounting position of the pulley.
- All types of mounting brackets must be fully supported by and fastened to the conveyor frame such that the shaft ends do not deform. Shaft ends must always be fully supported by the brackets..
- Mounting brackets should be fitted such that they are in contact with the shoulder of each shaft. This will:
  1. Eliminate Motorized Pulley axial play between mounting brackets.
  2. Keep shaft deflection to a minimum.
- In noise-sensitive areas, the designer should use heavier gauge support structure and appropriate vibration isolating material, as necessary.
- When Rulmecca Motorized Pulley mounting brackets are not used, it is essential that:
  1. The mounting equipment supports at least 80% of the shaft flats.
  2. The clearance between each shaft flat shoulder and its support is less than 0.030 inches.
- A Motorized Pulley with frequent reversible operations or many start/stops should be mounted with no axial clearance between the shaft flat and the brackets.
- Failing to follow these precautions could cause pulley and/or bracket damage and *voids product warranty*.

## 19) Non-Belt, Partial Belt, Modular Belt:

- Special Motorized Pulley designs are available for “non-belt, V-belt, partial belt, and modular belt” applications. See “Ambient Temperature Section” above.
- It is essential that each special application be designed to adequately dissipate heat from the pulley surface.
- Using a standard Motorized Pulley in one of these special applications could result in motor heat damage and *voids product warranty*.
- Contact Rulmecca for assistance with these applications.

## 20) Oil and Oil Seal Maintenance:

- All Motorized Pulleys are supplied with an appropriate quantity of oil. Oil type is specified by customer. Oil type and quantity are given on the motor nameplate. Only approved non-conductive oil may be used in Motorized Pulleys.
- Standard, synthetic, food grade, low viscosity (for low temperature applications,) and high viscosity (in noise-sensitive areas) are all available. For approved oil types and quantities, see page 93.
- Motorized Pulleys require periodic oil changes and are supplied with two oil fill/drain plugs in end housing. Special “vertical mount” pulleys have four oil plugs (two in each end housing.)
- Mineral oil should be changed after each 20,000 operating hours under normal operating conditions.
- Synthetic oils should be changed after each 50,000 operating hours under normal operating conditions.
- Magnetic oil plug(s) should be cleaned during each oil change.
- Note that oil seals, regardless of oil type used, should be changed after 30,000 operating hours. Rulmecca service personnel or authorized local service providers can perform this work.
- Take special precautions when changing brands of oil and types of oil because of potential oil incompatibility. Contact your local oil supplier for assistance. For example, when changing from standard to synthetic oil, it is necessary to:
  1. Completely drain old standard oil;
  2. Partially fill pulley with “Clean-Flush-Lubricate” (CFL) fluid;
  3. Run pulley for 20 minutes;
  4. Drain CFL fluid completely; then
  5. Fill pulley with appropriate amount of new synthetic oil.
- Failing to observe these oil & oil seal precautions could shorten pulley service life and *voids product warranty*.
- All the above instructions refer to Motorized Pulleys constantly working under full load. In case of Motorized Pulleys not working continuously under full load, the service life will increase considerably. When checking the oil, the cleanliness of the oil is always the best guideline of:
  - The wear and condition of the gears and bearings
  - Whether to change the oil immediately or possibly delay the oil change

## 21) Pulley Diameter:

- The type and size of conveyor belt will determine the minimum allowable Motorized Pulley diameter. Using a pulley diameter too small for the belt can cause belt delamination, belt splice damage and can shorten both belt and pulley lagging life. Contact your belting supplier before specifying a pulley diameter.



# Technical Precautions for Design, Installation and Maintenance



## 22) Regreasable Labyrinth Seals:

- All Rulmeca Motorized Pulleys are hermetically-sealed. Standard oil seals are designed to contain oil within the Motorized Pulley during normal operating conditions. They are capable of withstanding an internal pressure rise that occurs as the pulley motor temperature increases.
- Optional regreasable labyrinth seals are available to protect oil seals from harsh operating or maintenance conditions. Each labyrinth seal provides a barrier to prevent ingress of dust and fluid through the oil seal.
- In abrasive operating conditions labyrinth seals should be periodically grease-purged to flush abrasive dust away from the oil seal. Grease should always be seen at the labyrinth gap.
- If re-grease frequency is high, an automatic greasing system is recommended.
- In wet conditions (e.g. food processing), where it is common to wash down equipment with high-pressure detergent spray, labyrinth seals provide a physical barrier to protect oil seals. Since high-pressure sprays can remove grease from the labyrinth seal, grease is not used.
- Failing to perform proper labyrinth seal maintenance could shorten service life and *voids product warranty*.

## 23) Reversing Conveyors:

- All Motorized Pulleys for a three-phase power supply are reversible. Mechanical backstop option is not possible for reversible conveyor applications.
- The conveyor drive control system must be designed to bring the Motorized Pulley to a complete stop before reversing conveyor belt direction.
- Reversing conveyor direction without stopping the drive motor will damage motor and gearbox and *voids product warranty*.

## 24) Surface Coating:

- The standard model 165LS Motorized Pulley is supplied with powder coated end housings.
- All smaller standard Motorized Pulleys are supplied with aluminum end housings.
- Carbon steel shells and shafts are treated with anti-rust wax.
- Stainless steel end housings, shells, shafts, and terminal boxes receive no surface coating.

## 25) Storage of Motorized Pulleys:

- During storage, Rulmeca Motorized Pulleys must be:
  - stored in a building or, as a minimum, covered by an awning.
  - protected against direct sunlight so that sealing system does not dry out.
  - rotated 180 degrees every 6 months to lubricate all internal components.

- Check that Motorized Pulley is properly fixed to the test frame during the test.
- If Motorized Pulleys must be stored longer than 1 year, they must be tested before being put into operation. Such a test should include the following:
  - Motor winding should be checked with an insulation tester
  - Winding resistance should be checked
  - Thermal protector should be checked with a continuity tester
  - Pulley should be connected to power supply and run for 30 minutes
  - Pulley should then be checked to verify that there are no oil leaks
  - Pulley should then be checked to verify that pulley body temperature does not exceed +160° F

## 26) Start-up:

- Prior to initial start-up of Motorized Pulley:
  - Verify that Motorized Pulley nameplate data matches customer specification.
  - Ensure electrical connections are correct.
  - Check that Motorized Pulley is free to rotate.
  - Check that slack side belt tension is adequate to prevent belt slippage.
  - Check that belt is not over-tensioned.
  - Ensure that oil is present in the Motorized Pulley.

## 27) Terminal Box:

- Motorized Pulleys are available with terminal boxes or power cords.
- Switch off power supply & control circuit before opening terminal box.
- Each terminal box has one or more conduit nipples and a cover plate. Cover plate should be removed to facilitate termination of power and control wires within the terminal box. After wire connections are made cover plate should be replaced.
- Terminal boxes should never be disassembled or removed from the end of the shaft.
- Modifications to terminal boxes should only be made by an authorized Rulmeca service center or after obtaining permission and instructions, in writing, from Rulmeca.
- A wiring diagram is provided with each Motorized Pulley.
- Dismantling and reassembling a terminal box could cause a short circuit in the factory set (and tested) internal wiring and *voids product warranty*.

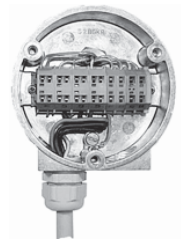

Terminal box



## Technical Precautions for Design, Installation and Maintenance

### 28) Transport and Handling:

- For safety reasons during transport and assembly a lifting rope suitable to support the weight of the pulley must be used. The weight of the pulley is stamped on the data plate and/or given in the catalog.
- The rope must be fixed on the shaft ends.
- Do not lift the Motorized Pulley by the power cord or terminal box.

### 29) Variable Frequency Drive:

- It is essential that each Variable Frequency Drive (VFD) be set to insure proper cooling of the motor. Motorized Pulleys dissipate motor heat into conveyor belts by using oil as a heat transfer medium. If operators attempt to drive the motor too slow or too fast, then oil circulation and motor cooling can become problematic and *product warranty is void*.
- When driving Rulmeca Motorized Pulleys at various frequencies with VFDs, make sure to set the device in "vector mode". In general, there will be no more than 5% torque loss. That means a Rulmeca Motorized Pulley may be set to deliver essentially "constant torque" within a set frequency range. However, do not undersize the conveyor drive when configured in this manner. Make certain the conveyor drive provides enough belt pull at each end of the desired belt speed range. Remember that horsepower is linearly proportional to frequency.
- Operating frequency ranges of 1Hz to 100Hz are possible, depending on various parameters including but not limited to ambient temperature, nominal belt speed and required belt pull. Contact Rulmeca for assistance with these special applications.
- It is possible for certain brands of VFD to set up resonant frequencies in the power line between the VFD and the motor if the power line is too long. These can cause voltage spikes in the motor. Potential resonant frequencies may be eliminated as follows: (1) limit the distance between the VFD and the motor (some VFD manufacturers recommend cable lengths of 30 feet or less), (2) install a filter on the VFD output (available from VFD manufacturer), and/or (3) select a VFD which modulates pulse width in a manner so as to avoid resonance.
- To avoid any electromagnetic interference, the cable from motor to the VFD should be screened and properly grounded.
- The power and current range of the VFD must be selected according to the full load amperage given on the Motorized Pulley data plate.
- Contact VFD supplier to properly match the VFD capabilities with the conveyor operating requirements and Motorized Pulley electrical characteristics.



## Product description

### Characteristics

- Standard end housings for LS series Motorized Pulleys include unpainted aluminum exterior surface, brass socket head oil plugs, double lip nitrile rubber shaft seals, and PTFE deflection seals. This seal system has a protection rating of IP66.
- Optional TS8N end housings for LS series include smooth stainless steel exterior surface, stainless steel flat head screw oil plugs, double lip Viton® shaft seals, and PTFE deflection seals. This seal system has a protection rating of IP69.

### Protection Ratings

- IP66 sealing insures that equipment is “dust tight” and protected from projections of water which are similar to marine swells.
- IP69 sealing insures that equipment is “dust tight” and can withstand high pressure cleaning from various angles for 30 seconds/each at a distance of 4” to 6” at a pressure of 2,150 psi with a water temperature of +176° F.



Standard aluminum end housing with oil plugs



Standard aluminum end housing without oil plugs



Stainless steel end housing (TS8N) with oil plugs



Stainless steel end housing (TS8N) without oil plugs



## Oil Quantities and Oil Types

Oil Quantity (pints)				
RL (in.)	80LS	113LS	138LS	165LS
7.87	0.2			
9.84	0.3	0.7		
11.81	0.4	0.9	1.5	
13.78	0.5	1.1	2.0	2.5
15.75	0.5	1.4	2.5	3.0
17.72	0.6	1.6	3.0	3.5
19.69	0.7	1.8	3.0	4.0
21.65	0.8	2.1	4.0	4.0
23.62	0.9	2.3	4.0	5.0
25.59	1.0	2.5	4.5	5.5
27.56	1.1	2.8	5.0	5.5
29.53	1.1	3.0	5.5	6.0
31.50	1.2	3.2	6.0	6.5
33.46	1.3	3.5	6.5	7.0
35.43	1.4	3.7	7.0	7.5
37.40	1.5	3.9	7.0	8.0
39.37	1.6	4.2	8.0	8.0
41.34		4.4	8.0	8.5
43.31		4.6	8.5	9.5
45.28		4.9	9.0	9.5
47.24		5.1	9.5	10.0
49.21			9.5	10.5
51.18			10.0	11.0
53.15			10.5	11.5
55.12			11.0	12.0
57.09			11.0	12.0
59.06			10.0	12.5
61.02			10.5	12.0
62.99			11.0	12.5
64.96			11.0	13.0
66.93			11.5	13.5
68.90			12.0	14.0
70.87			12.5	14.5
72.83			12.5	15.0
74.80				15.0
76.77				15.5
78.74				16.0

**Note:** The oil contents shown above are valid for standard unlagged drum motors only. For special options the oil quantity can deviate. Therefore always use the given oil quantity shown on the data plate.

# Oil Quantities and Oil Types



Motorized Pulley Oil type	IEC34 Insulation Class	Ambient Temp.	ISO 3498 DIN51519	DIN 51517	Castrol	BP	ESSO Mobil	Shell	Texaco	Fuchs
<b>80LS Mineral</b>	F	23°F +104°F	CC ISOVG 68	CLP ISOVG 68	ALPHA SP 68	ENERGOL GR-XP 68	MOBILGEAR 600 XP 68	OMALA 68	MEROPA 68	
<b>80LS Synthetic</b>	F & H	-13°F +104°F	CC ISOVG 68	CLP ISOVG 68	ALPHA SYN T 68		SHC 626 68			
<b>80LS Synthetic food grade</b>	F & H	-40°F +104°F	CC ISOVG 68	CLP ISOVG 68			<b>CIBUS 68*</b>			CASSIDA FLUID HFS 68
<b>113LS Mineral</b>	F	23°F+104°F	CC ISOVG 150	CLP ISOVG 150	ALPHA SP 150	ENERGOL GR-XP 150	MOBILGEAR 600 XP 150	OMALA 150	MEROPA 150	
<b>113LS Synthetic</b>	F & H	-13°F +104°F	CC ISOVG 150	CLP ISOVG 150	ALPHA SYN T 150		SHC 629 150			
<b>113LS Synthetic food grade</b>	F & H	-22°F +104°F	CC ISOVG 150	CLP ISOVG 150			<b>CIBUS 150*</b>			CASSIDA GL150
<b>138LS - 165LS Mineral</b>	F	23°F +104°F	CC ISOVG 150	CLP ISOVG 150	ALPHA SP 150	ENERGOL GR-XP 150	MOBILGEAR 600 XP 150	OMALA 150	MEROPA 150	
<b>138LS - 165LS Synthetic</b>	F & H	-13°F +104°F	CC ISOVG 220	CLP ISOVG 220	ALPHA SYN T 220		SHC 630 220			
<b>138LS - 165LS Synthetic food grade</b>	F & H	-22°F +104°F	CC ISOVG 220	CLP ISOVG 220			<b>CIBUS 220*</b>			CASSIDA GL220

\* These brands and specifications are supplied as standard from Rulmeca Corporation, Wilmington, North Carolina.

Oil contents for vertical mounting regardless of roller length		
Model	Pints	Special construction
<b>80LS</b>	0.4	Electrical connection must be located at the top
<b>113LS</b>	1.3	
<b>138LS</b>	3.0	
<b>165LS</b>	6.5	

**Note:** The given oil contents are valid for standard unlagged drum motors only. For special options the oil quantity can deviate. Therefore always use the given oil quantity shown on the data plate.



# 113LS Connection Diagrams

Terminal Box - 3 Phase - US Motor

Code:

T1 & T2: Thermal protection

B1 & B2: internal brake

rd - red

bn - brown

bk - black

gy - gray

bu - blue

vt - violet

wh - white

## Low Voltage

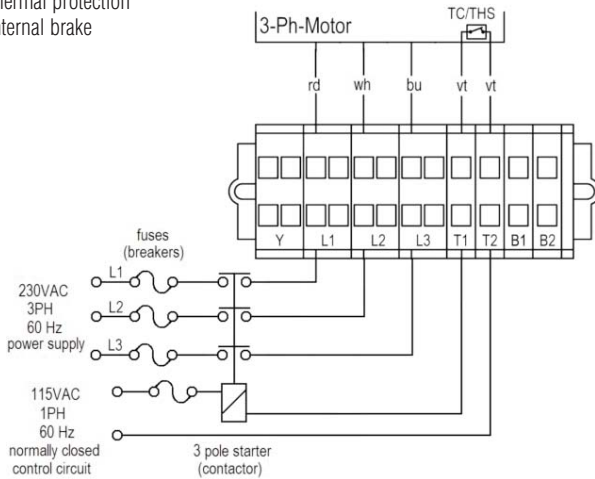

## High Voltage

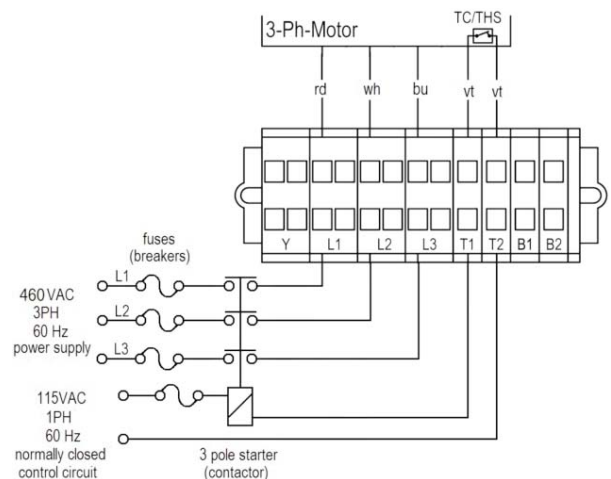

## Low Voltage with Brake Option

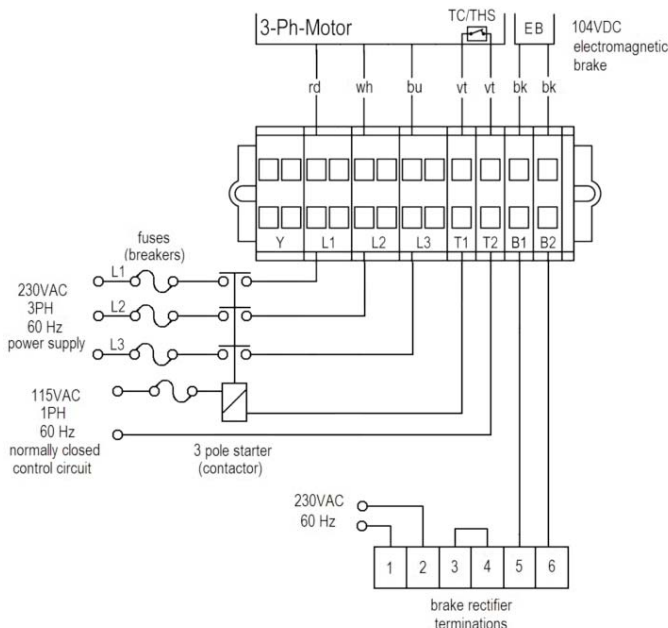

## High Voltage with Brake Option

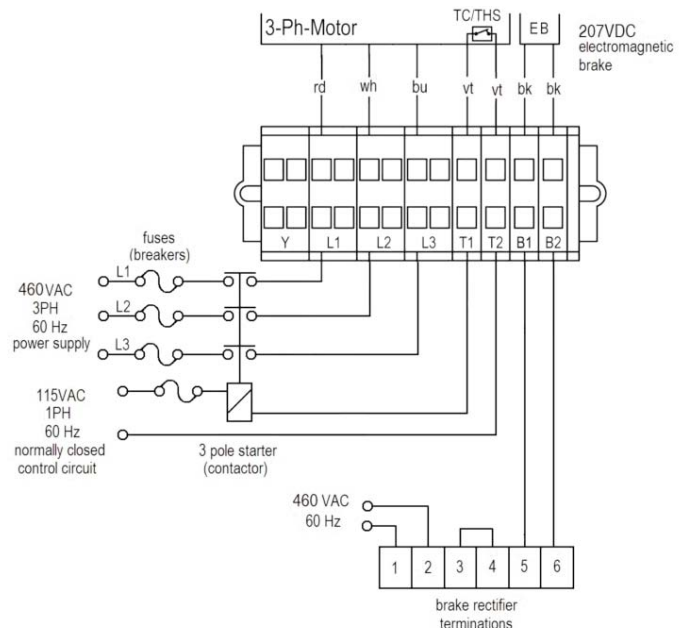

### Assembly instructions

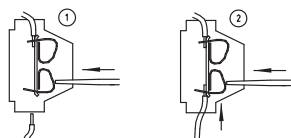

Push down clamp

Push in wire

### NOTE:

Brake rectifier is shown with jumper across terminals 3 & 4. This enables AC power supply to rectifier to stop and start brake. Brake responsiveness may be improved by connecting an external switch to terminals 3 & 4.

# 113LS Connection Diagrams

Terminal Box - 1 Phase - US Motor



Code:

T1 & T2: Thermal protection

B1 & B2: internal brake

rd - red

bn - brown

gy - gray

vt - violet

wh - white

**Low Voltage - Clockwise Rotation**

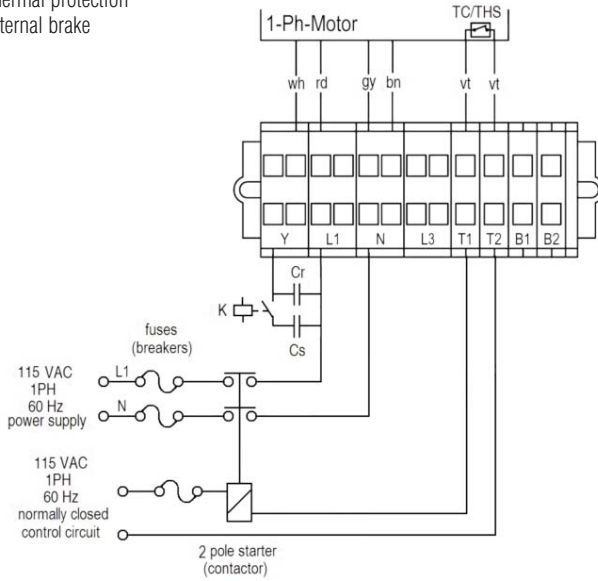

**Low Voltage - Counterclockwise Rotation**

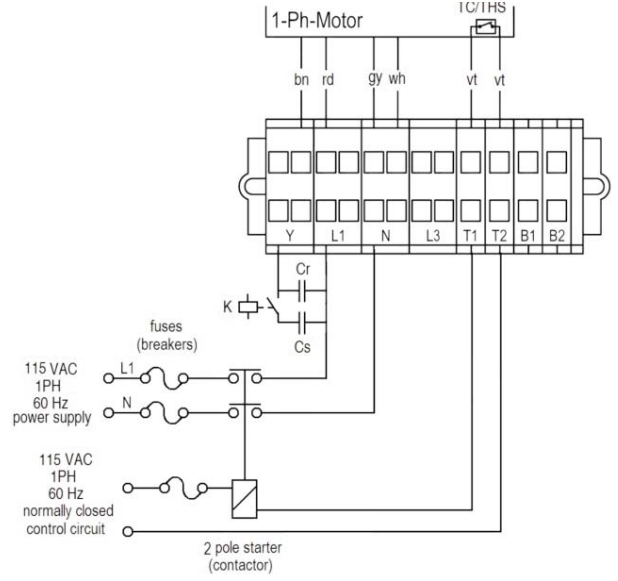

**High Voltage - Clockwise Rotation**

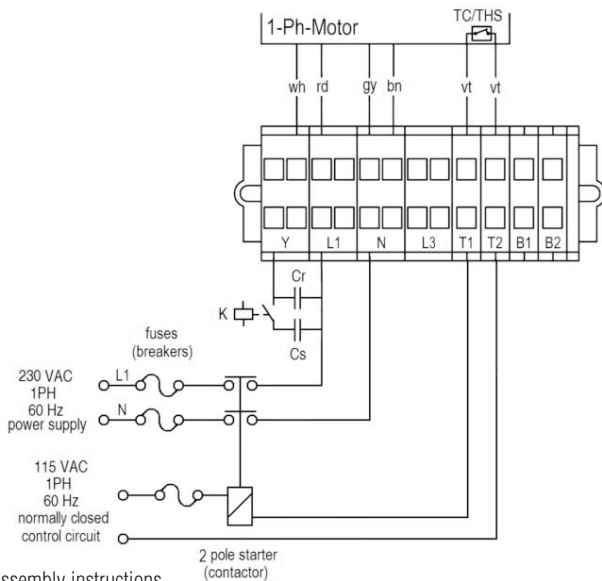

**High Voltage - Counterclockwise Rotation**

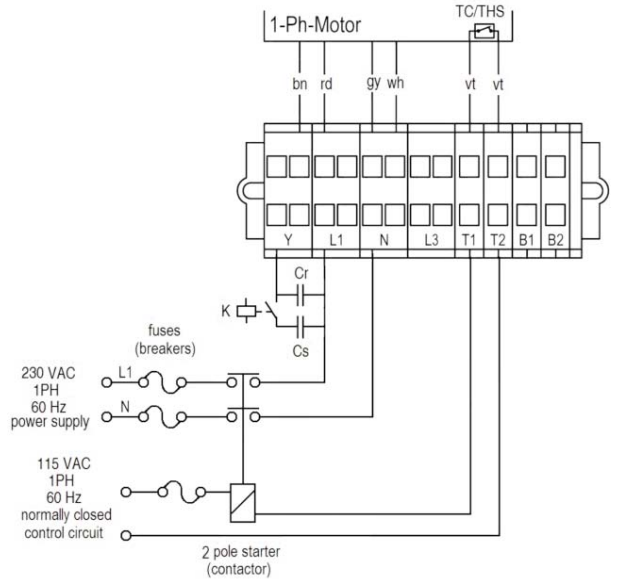

Assembly instructions

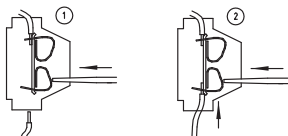

Push down clamp    Push in wire



# 113LS Connection Diagrams

## Terminal Box - 3 Phase - European Motor

Code:

T1 & T2: Thermal protection

B1 & B2: internal brake

rd - red

bn - brown

bk - black

gy - gray

bu - blue

vt - violet

wh - white

### Low Voltage

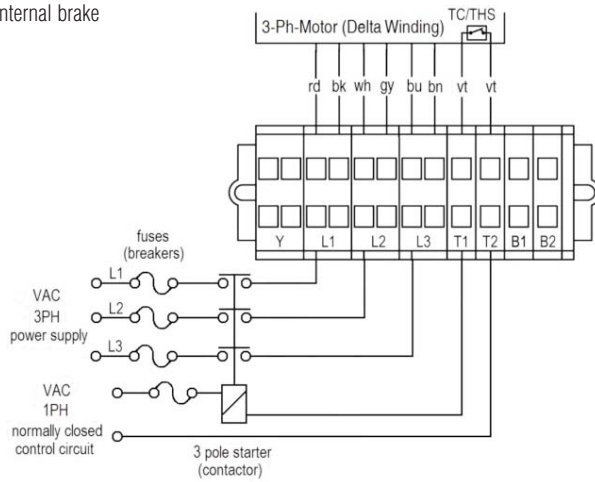

### High Voltage

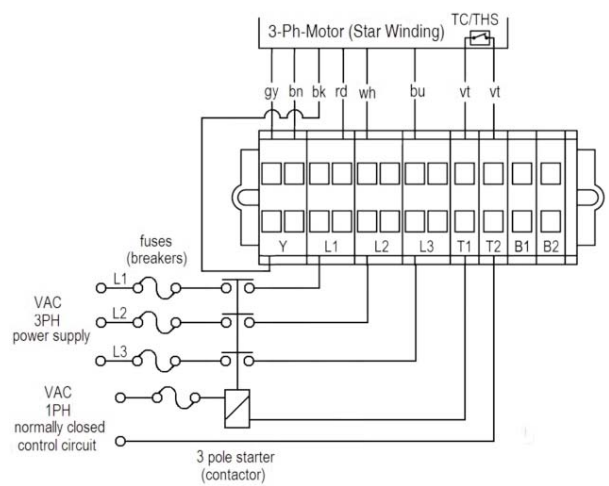

### Low Voltage With Brake Option

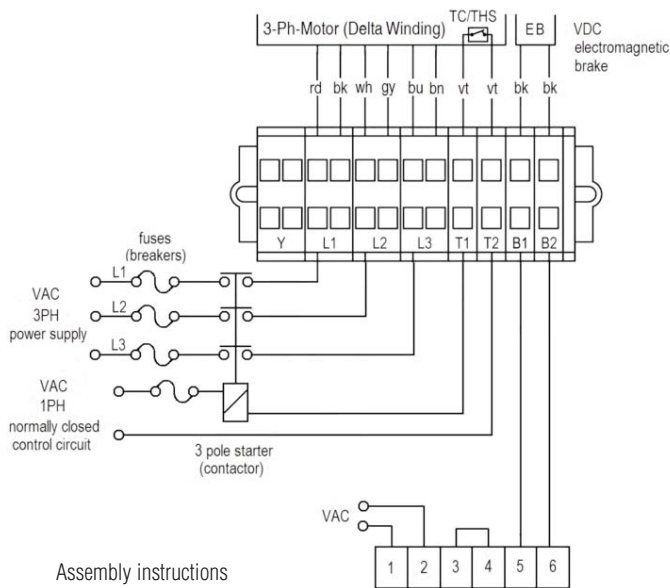

### High Voltage With Brake Option

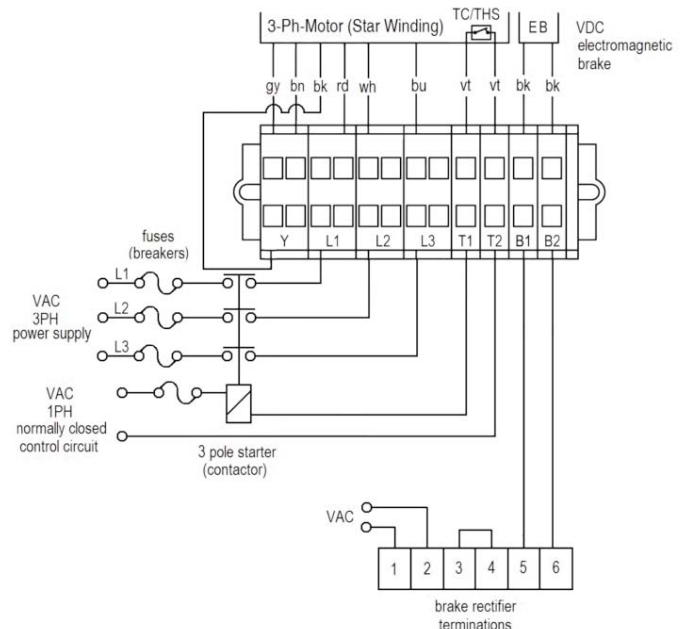

#### Assembly instructions

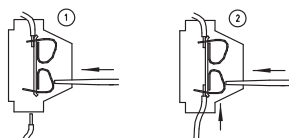

Push down clamp

Push in wire

#### NOTE:

Brake rectifier is shown with jumper across terminals 3 & 4. This enables AC power supply to rectifier to stop and start brake. Brake responsiveness may be improved by connecting an external switch to terminals 3 & 4.



# 138LS - 165LS Connection Diagrams

Terminal Box - 3 Phase - US Motor



Code:

T1 & T2: Thermal protection

B1 & B2: internal brake

rd - red

ye - yellow

bk - black

gy - gray

bu - blue

gn - green

wh - white

bn - brown

## Low Voltage

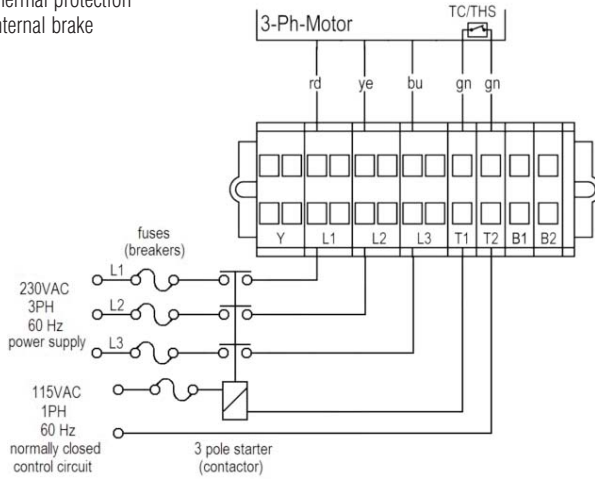

## High Voltage

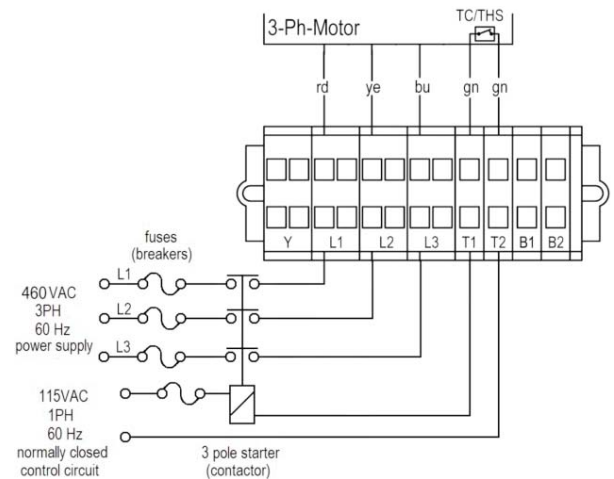

## Low Voltage with Brake Option

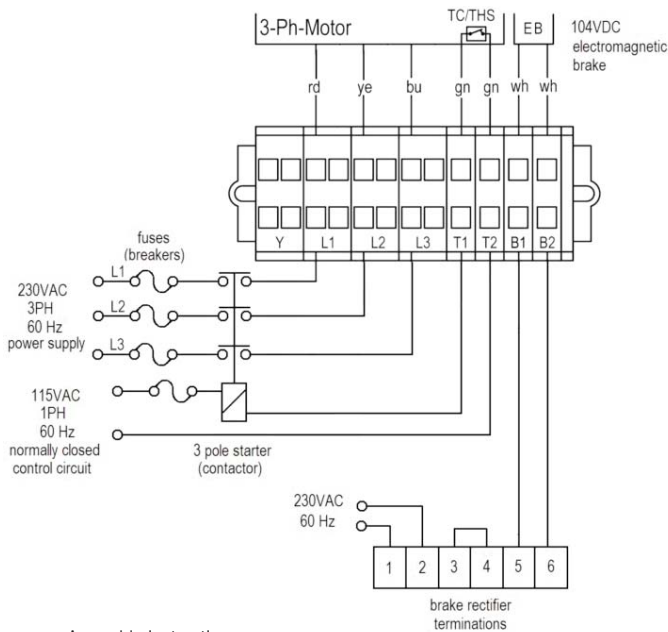

## High Voltage with Brake Option

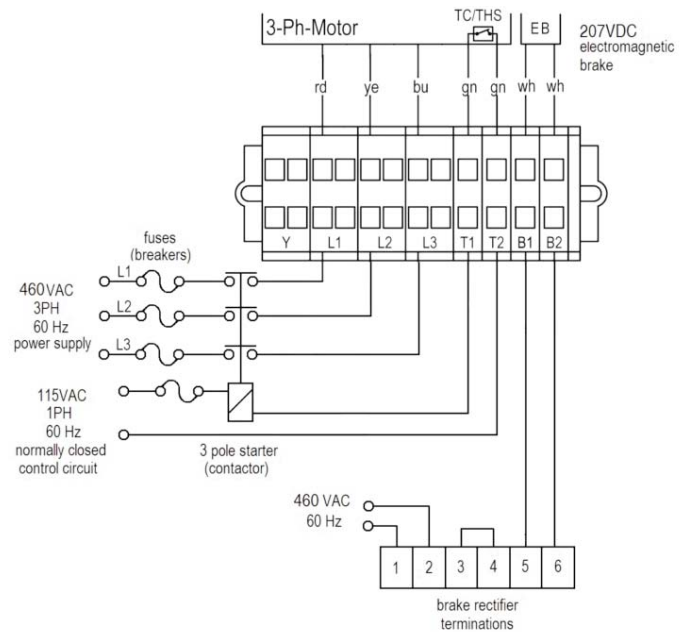

### Assembly instructions

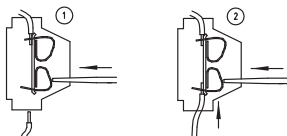

Push down clamp    Push in wire

### NOTE:

Brake rectifier is shown with jumper across terminals 3 & 4. This enables AC power supply to rectifier to stop and start brake. Brake responsiveness may be improved by connecting an external switch to terminals 3 & 4.



# 138LS Connection Diagrams

Terminal Box - 1 Phase - US Motor

Code:

T1 & T2: Thermal protection

B1 & B2: Internal brake

Cr: Run Capacitor

Cs: Start Capacitor

K: Start Capacitor Relay

rd - red

ye - yellow

bk - black

bu - blue

gn - green

**Low Voltage - Clockwise Rotation**

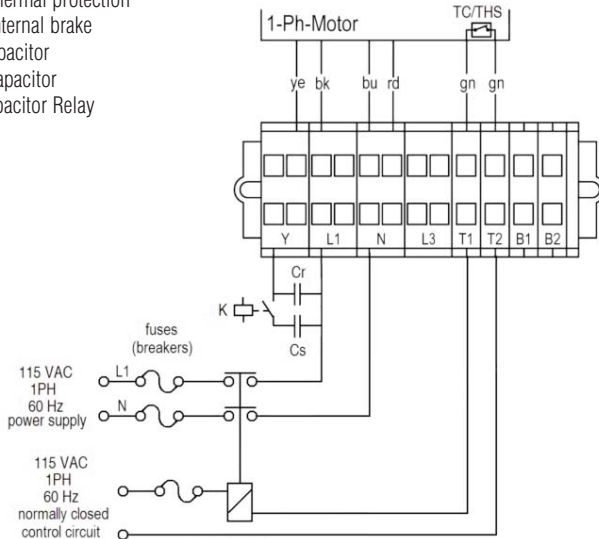

**Low Voltage - Counterclockwise Rotation**

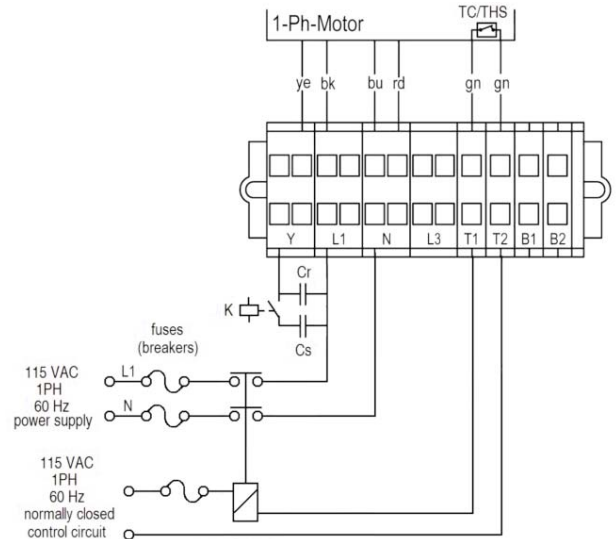

**High Voltage - Clockwise Rotation**

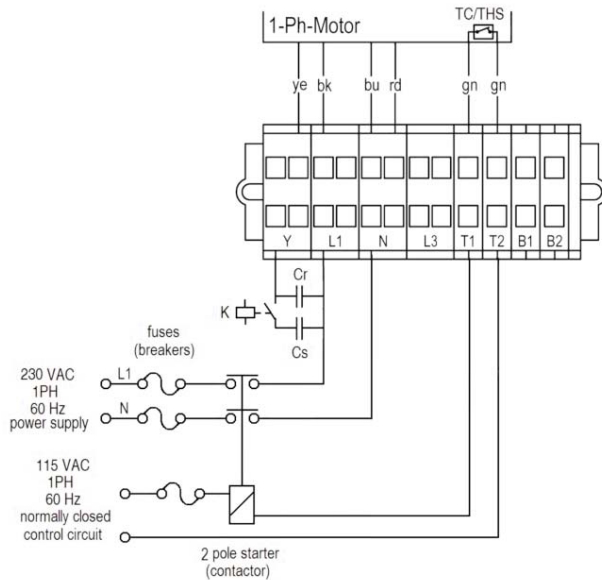

**High Voltage - Counterclockwise Rotation**

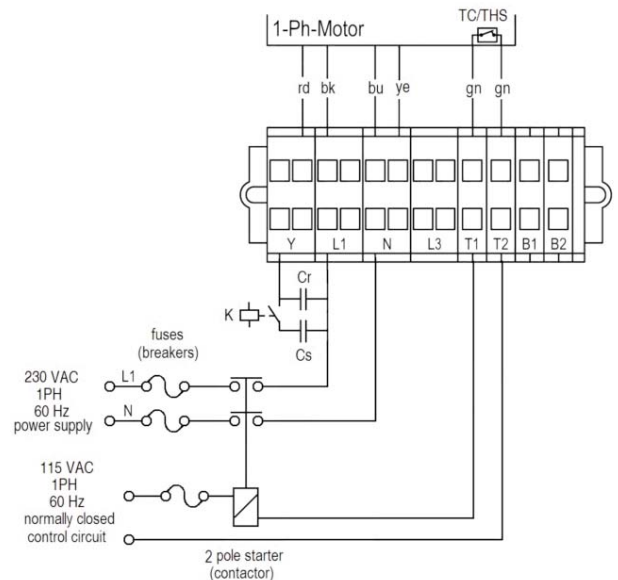

**Assembly instructions**

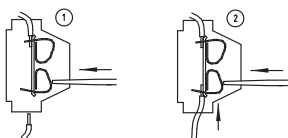

Push down clamp

Push in wire

# 138LS - 165LS Connection Diagrams

Terminal Box - 3 Phase - European Motor



Code:

T1 & T2: Thermal protection

B1 & B2: Internal brake

rd - red

ye - yellow

bk - black

gy - gray

bu - blue

gn - green

wh - white

bn - brown

## Low Voltage

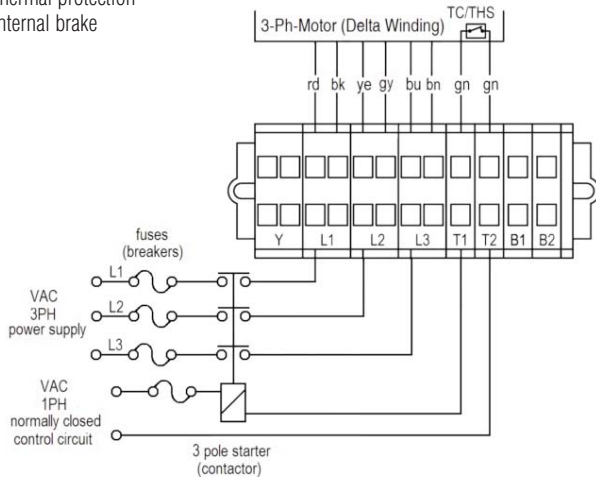

## High Voltage

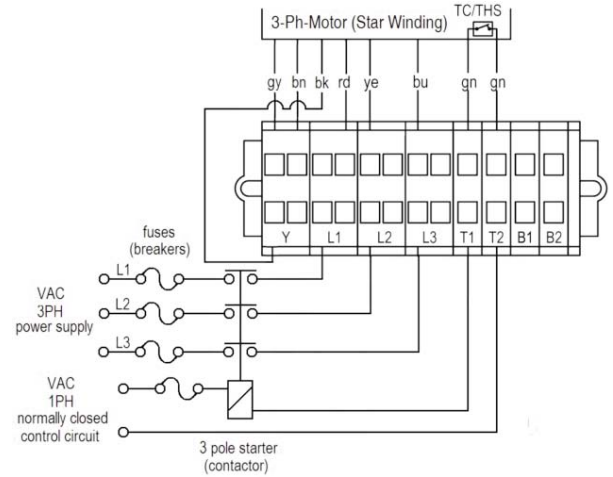

## Low Voltage with Brake Option

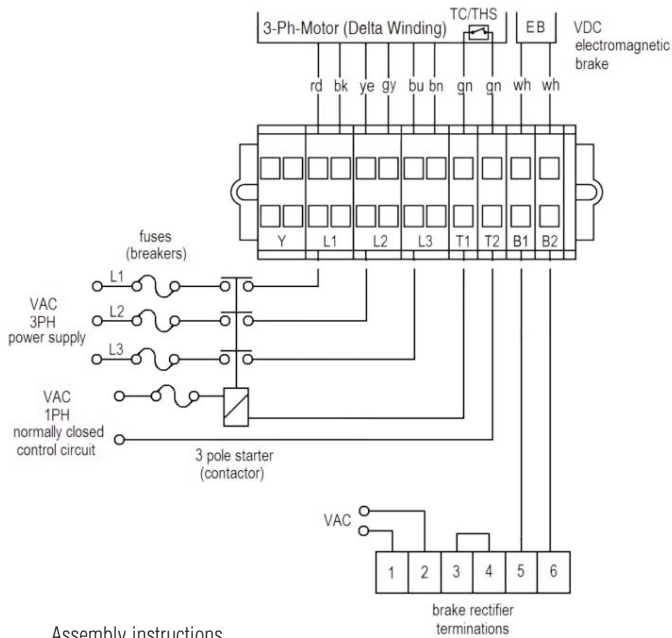

## High Voltage with Brake Option

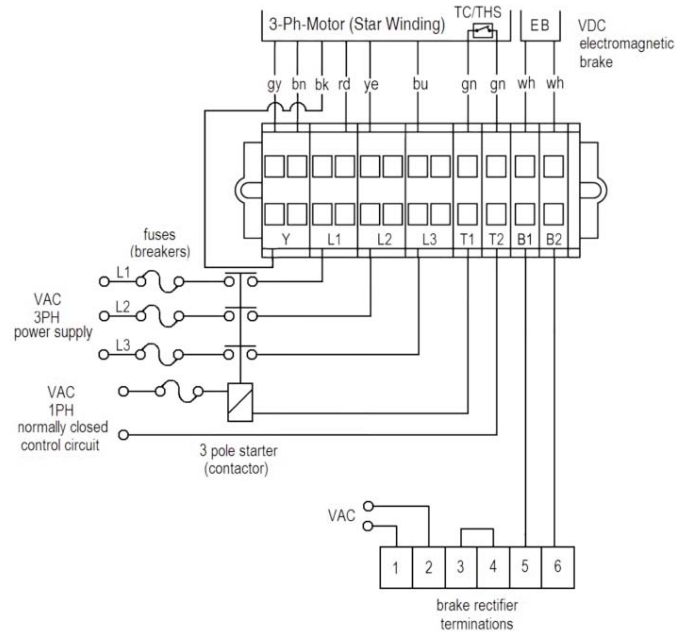

### Assembly instructions

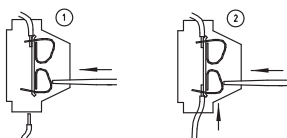

Push down clamp    Push in wire

### NOTE:

Brake rectifier is shown with jumper across terminals 3 & 4. This enables AC power supply to rectifier to stop and start brake. Brake responsiveness may be improved by connecting an external switch to terminals 3 & 4.



# 80LP-113LP Connection Diagrams

Power Cord (6 wire) - 3 Phase - US Motor

Code:

T1 & T2: Thermal protection

bn - brown

bk - black

ye - yellow

bu - blue

wh - white

gn/ye - green yellow

## Low Voltage

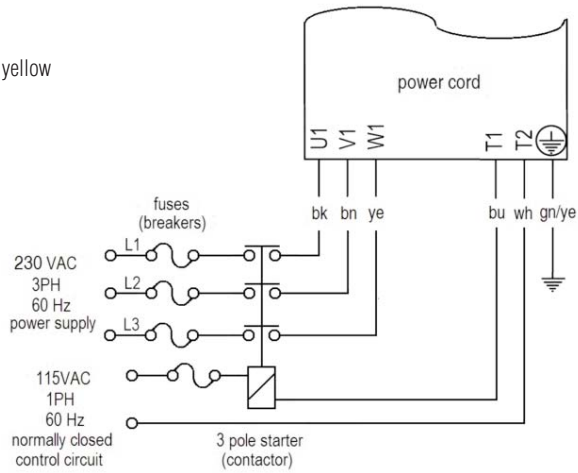

## High Voltage

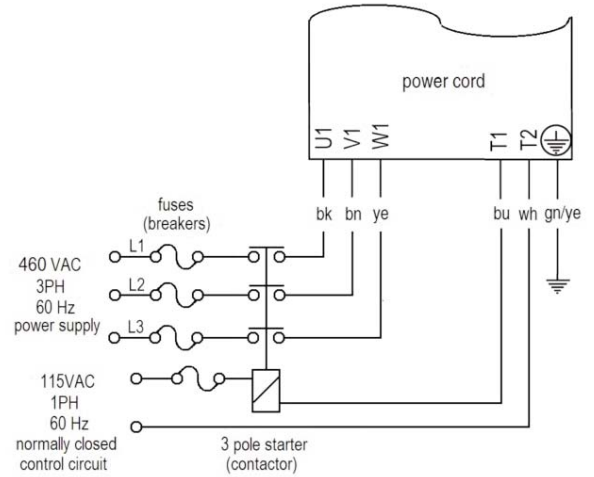

# 80LP-113LP Connection Diagrams

## Power Cord (9 wire) - 3 Phase - European Motor



Code:

T1 & T2: Thermal protection

bn - brown

vy - violet

bk - black

rd - red

ye - yellow

bu - blue

wh - white

gy - gray

gn/ye - green yellow

### Low Voltage

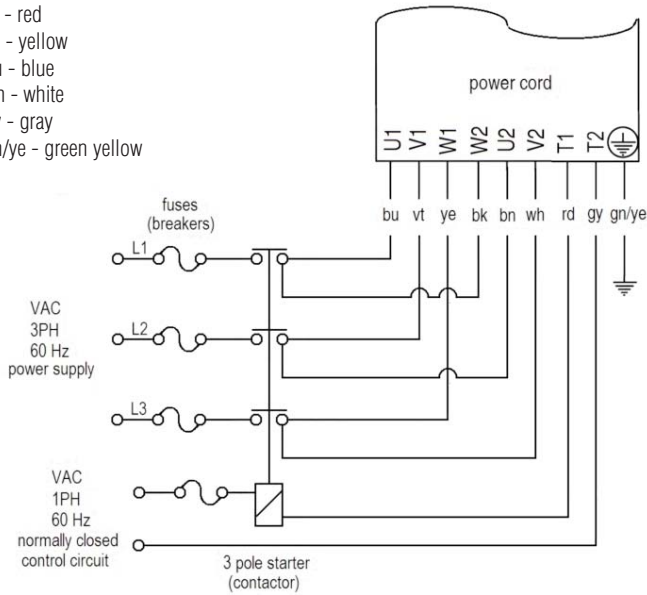

### High Voltage

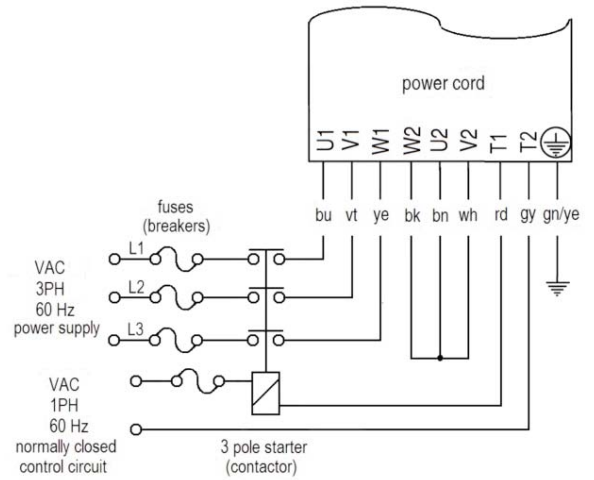



# 80LP-113LP Connection Diagrams

Power Cord (7 wire) - 1 Phase - US Motor

Internal Thermal Protection Switch not in series with motor

Code:  
 T1 & T2: Thermal protection  
 Cr: Run Capacitor  
 bk - black  
 bn - brown  
 wh - white  
 bu - blue  
 ye - yellow  
 vt - violet  
 gn/ye - green yellow

**Low Voltage - Clockwise Rotation**

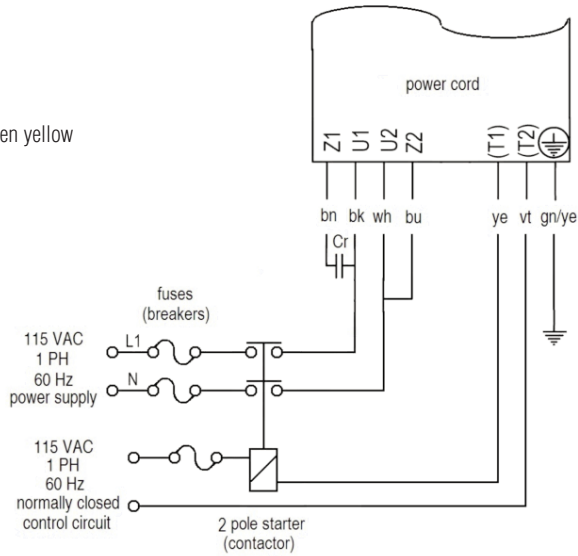

**Low Voltage - Counterclockwise Rotation**

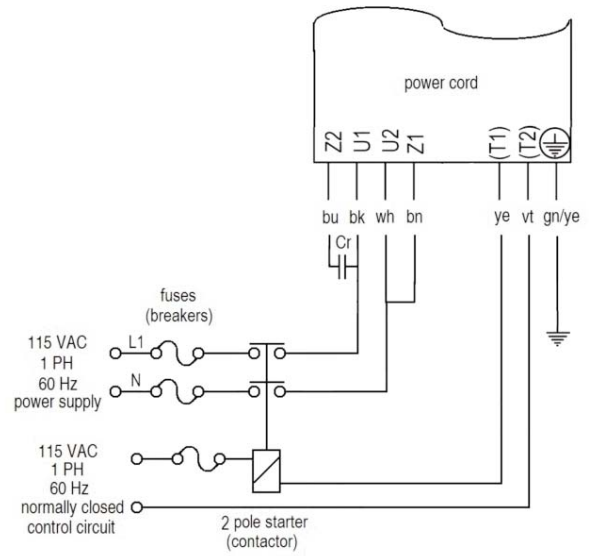

**High Voltage - Clockwise Rotation**

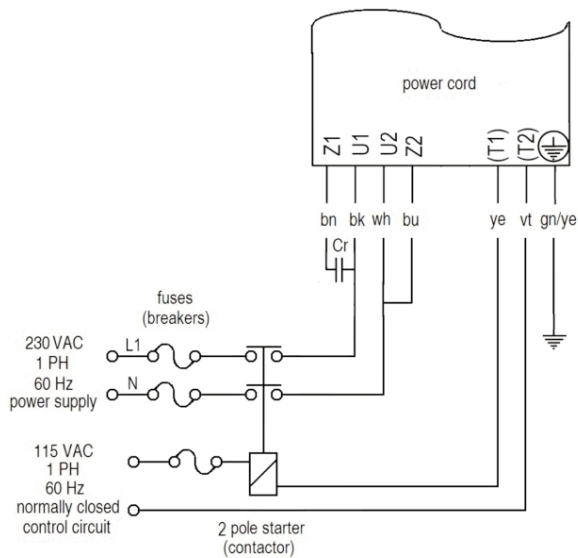

**High Voltage - Counterclockwise Rotation**

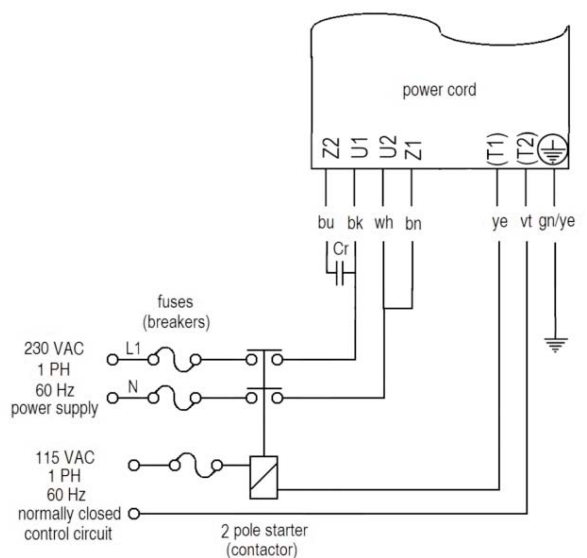

**NOTE:**

The thermal switch in this single phase motor is not installed in series with motor winding. Therefore, the switch must be connected to a normally closed control circuit to deactivate motor.

# 80LP - 113LP Connection Diagrams

Power Cord (7 wire) - 1 Phase - US Motor

Internal Thermal Protection Switch in series with motor

Code:

Cr: Run Capacitor

bk - black

bn - brown

wh - white

bu - blue

gn/ye - green yellow

two wires are not used

**Low Voltage - Clockwise Rotation**

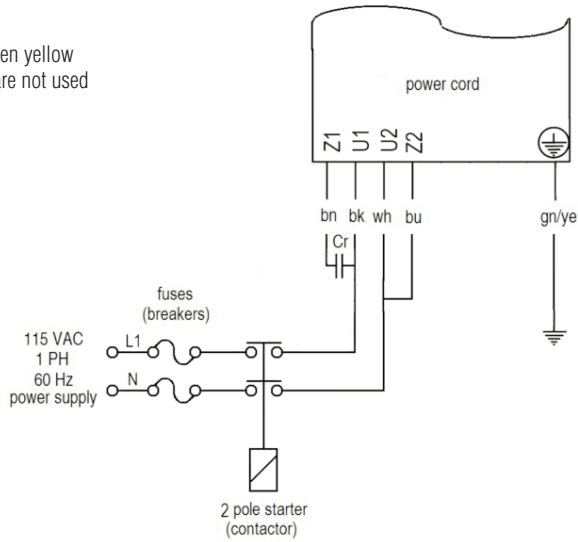

**Low Voltage - Counterclockwise Rotation**

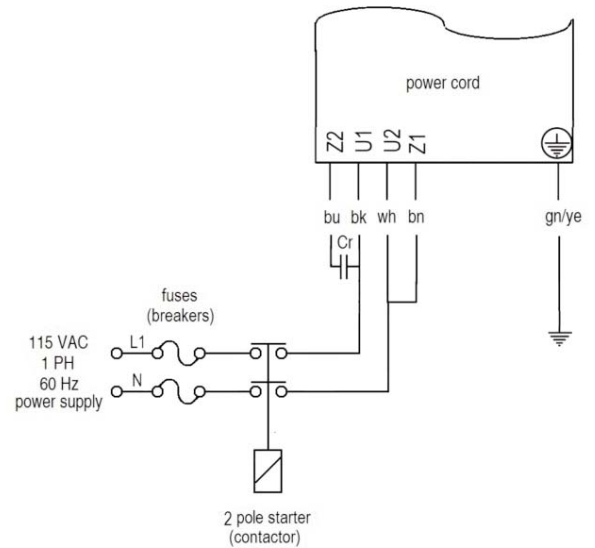

**High Voltage - Clockwise Rotation**

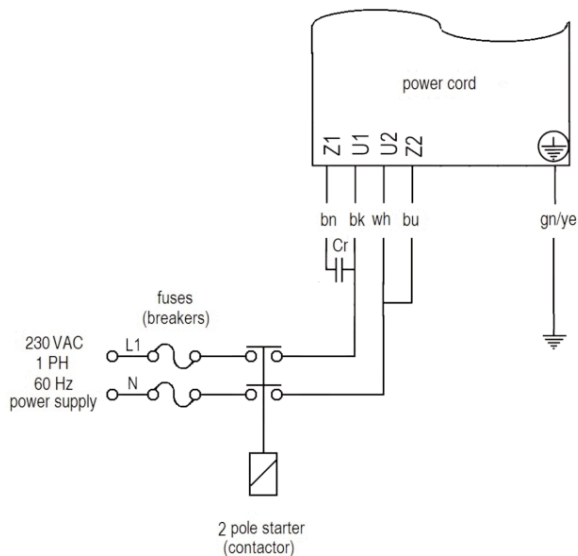

**High Voltage - Counterclockwise Rotation**

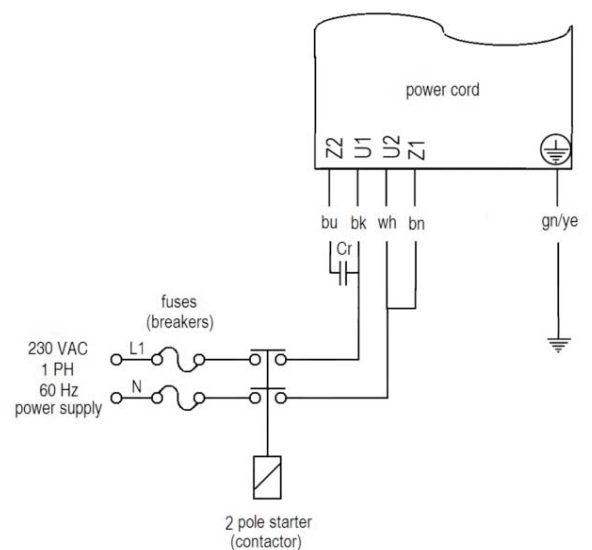

NOTE:

The thermal switch in this single phase motor is installed in series with motor winding. Therefore, the switch can deactivate and re-energize motor automatically.



# 80LS - 165LS Connection Diagrams

Power Cord (7 wire) - 3 Phase - US Motor

Code:  
T1 & T2: Thermal protection

## Low Voltage

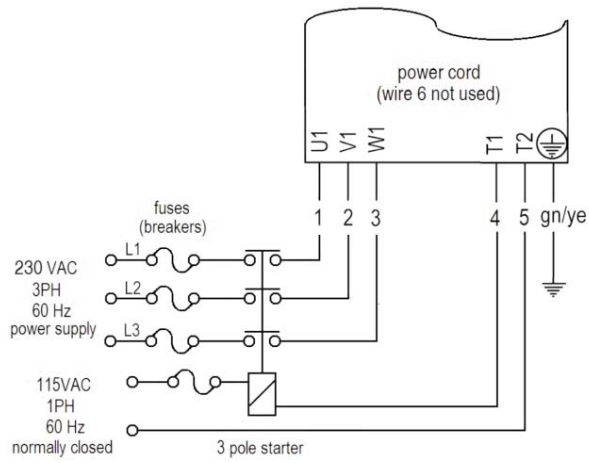

## High Voltage

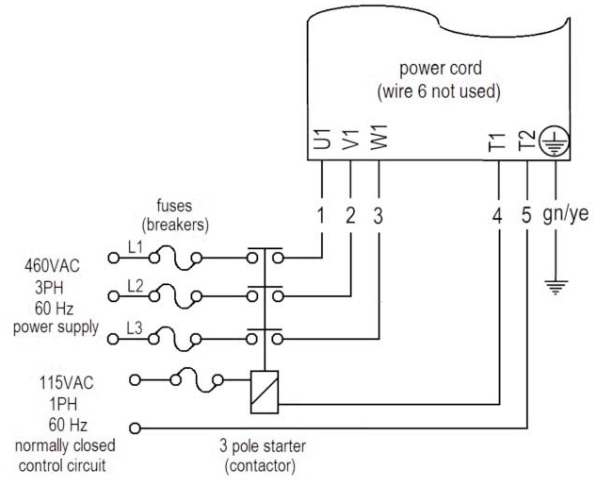



# 80LS - 165LS Connection Diagrams

Power Cord (9 wire) - 3 Phase - US Motor



Code:

T1 & T2: Thermal protection

B1 & B2: Internal brake

**Low Voltage**

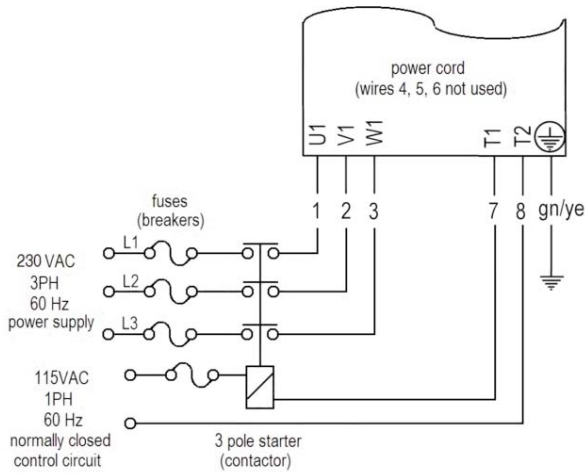

**High Voltage**

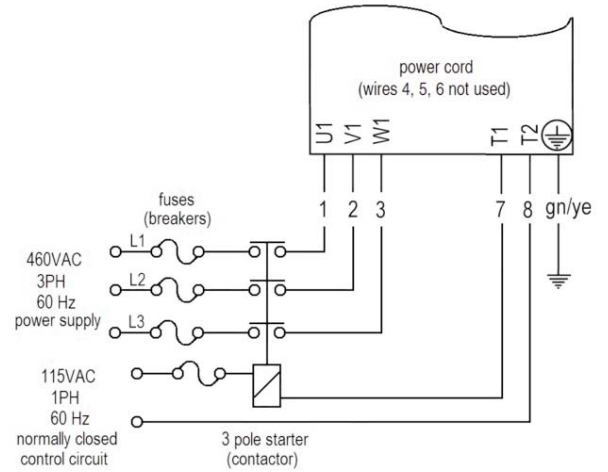

**Low Voltage with Brake Option**

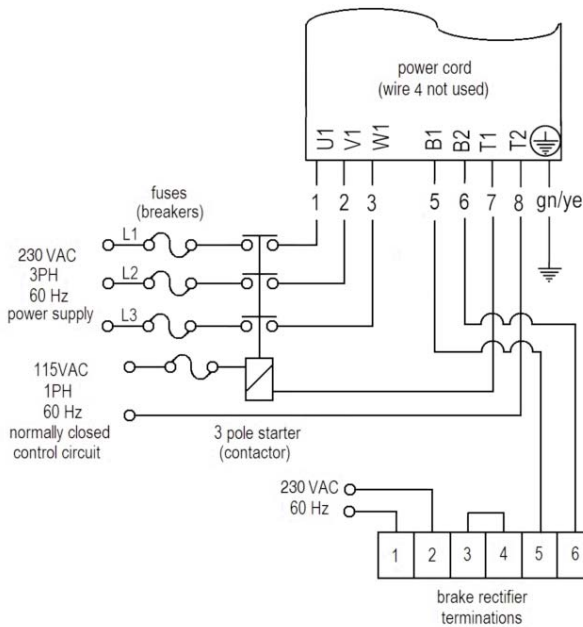

**High Voltage with Brake Option**

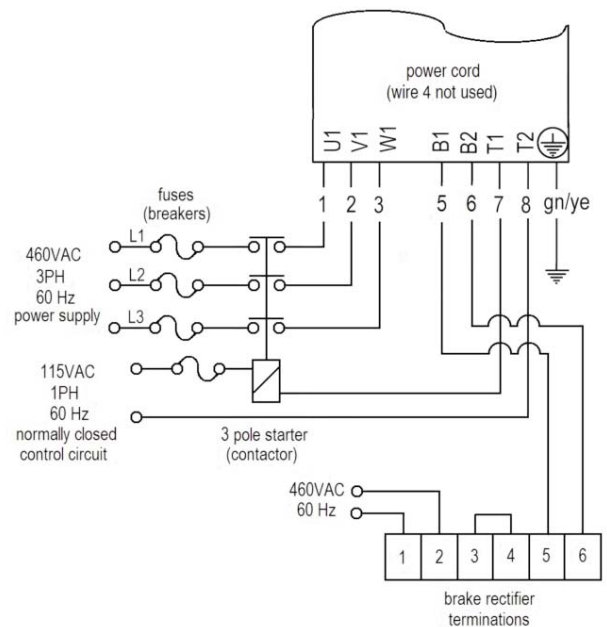



# 138LS Connection Diagrams

Power Cord (9 wire) - 1 Phase - US Motor

Code:  
 T1 & T2: Thermal protection  
 B1 & B2: Internal brake  
 Cr: Run Capacitor  
 Cs: Start Capacitor (optional)  
 K: Start Capacitor Relay

**Low Voltage - Clockwise Rotation**

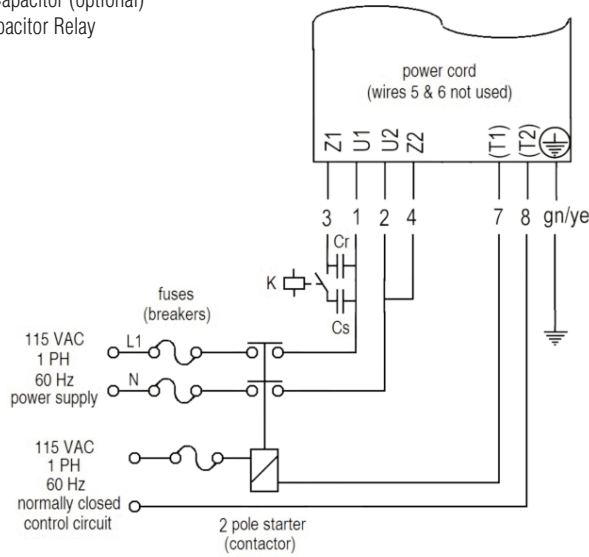

**Low Voltage - Counterclockwise Rotation**

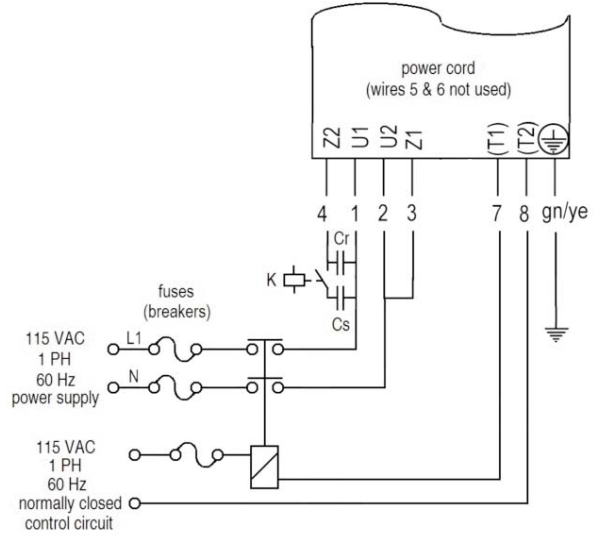

**High Voltage - Clockwise Rotation**

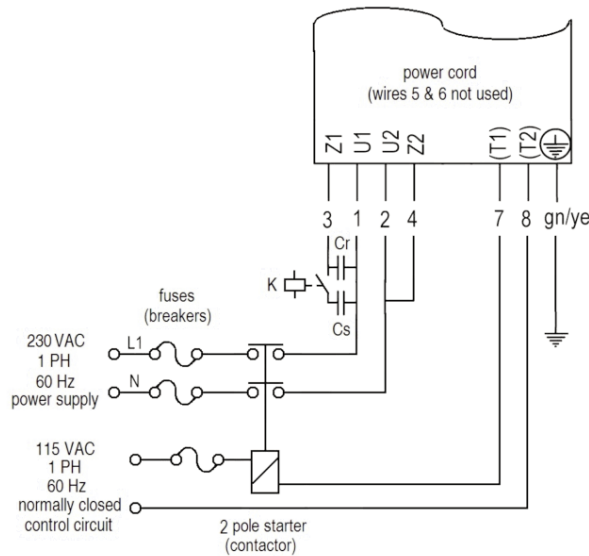

**High Voltage - Counterclockwise Rotation**

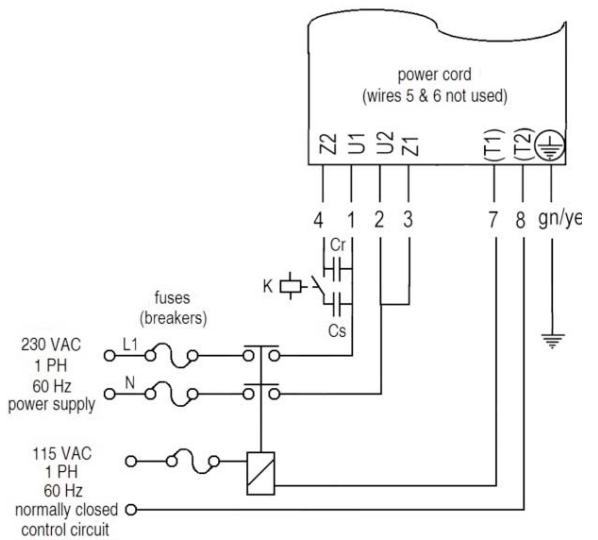

# 80LS - 165LS Connection Diagrams

## Power Cord (9 wire) - 3 Phase - European Motor



Code:  
T1 & T2: Thermal protection

Note:  
Motors shown on this page are dual voltage (Star/Delta). This type of motor is not available with electromagnetic brake. Contact Rulmecca for additional details.

