



Motorized Pulley 220M & 220H, Ø 8.50 in. (216 mm)

Our 8.50" diameter Motorized Pulley range offers two different performance levels for BULK applications:

- M for Medium duty
- H for Heavy duty

It is important to note the product differences and choose the appropriate pulley based on estimated belt tension (radial load.) See page 78. The actual radial load must be less than the maximum allowable radial load shown in this catalog.

Be aware of increased belt tensions required to drive multi-ply thick heavy belts and/or larger belt widths.

If the 8.50" diameter model is not strong enough to resist estimated belt tension, then select 12.64" diameter model.

M for Medium duty

The internal parts of 220M are designed to match irregular working conditions in applications such as mobile crushing & screening, cement & concrete plants, mobile conveyors and open stone & gravel pits.

H for Heavy duty

A reinforced 3-stage-gearbox provides 220H with the necessary strength needed for low speeds and high torque. 220H is popular in recycling (hand sorter conveyors), bunker discharge conveyors and where a combination of slow speed and high torque is required.

STANDARD SPECIFICATION of Motorized Pulley

- Crowned mild steel 8.50" diameter steel shell treated with anti-rust wax
- Powder coated cast iron bearing housings
- Mild steel shafts treated with anti-rust wax
- Shaft sealing system - degree of protection IP66/67 (EN60034-5.) See page 88.
- Powder coated die cast aluminum terminal box
- 3-phase induction motors with thermal protector
- Voltage: All common voltages available. Please specify.
- Motor winding insulation Class F
- Dynamically balanced rotor
- One out of two oil plugs fitted with a magnet to filter the oil
- Oil change recommended every 50,000 operational hours for synthetic oil and 10,000 operational hours for standard oil.
- Minimum RL. Please refer to pages 23-24
- Maximum RL – Please inquire
- Non standard RL's available
- To be used in horizontal positions ± 5 degree only

Please note:

- **Noise-sensitive Areas:** High speed 2-pole motors can cause higher noise levels and are not recommended for noise-sensitive areas
- **Technical Precautions for Design, Installation, and Maintenance:** pages 76-86
- **Environmental Considerations:** page 72
- **Optional Extras:** pg 21 and back cover
- **Electrical Connection Diagrams:** pages 94-96.

STAINLESS STEEL options

TS9N

- Stainless steel shell – AISI 304 range
- Stainless steel shafts – AISI 303/4 range
- Stainless steel covered bearing housings – AISI 316 range
- Stainless steel oil plugs – AISI 304 range – one out of two with magnet
- Stainless steel exterior bolts – AISI 304 range
- Regreasable labyrinth seals with grease nipples in stainless steel – AISI 304 range
- Shaft sealing system – degree of protection IP66/67 (EN60034-5).

TS10N

- As TS9N, but without regreasable labyrinth seals.

SEMI-RUST-FREE options

TS11N

- As TS9N, but with crowned mild steel shell treated with anti-rust wax.

TS12N

- As TS10N, but with crowned mild steel shell treated with anti-rust wax.

Other Stainless Options:

- FDA & USDA food grade recognized oil and grease are not included in TS9N to TS12N, but available on request
- Complete Motorized Pulleys in acid resistant stainless steel – AISI 316 range – available on request.
- Special mounting brackets are available

Electrical connection options:

- Salt water resistant powder coated aluminum terminal box with zinc plated exterior bolts
- Stainless steel terminal box – AISI 304 range (max. 5.5 HP)
- Straight stainless steel connector with flying lead – AISI 304 range.

Please specify required TS-number when ordering Stainless Steel options.



OPTIONAL EXTRAS

Motorized Pulley 220M & 220H

Specification	Availability
Total stainless steel option AISI 304 range TS9N with regreasable labyrinth seals	x
Total stainless steel option AISI 304 range TS10N with standard seals	x
Semi-rust free option TS11N with regreasable labyrinth seals	x
Semi-rust free option TS12N with standard seals	x
Regreasable labyrinth seals	x
Food grade oil & grease - FDA & USDA recognized	x
Dust explosion proof Motorized Pulleys - ATEX 95 - Zone 22 - for applications handling of dusty grain etc. According to European Directive 94/9/EC.	x
Total acid resistant stainless steel option - AISI 316	x
Black rubber lagging - Standard specifications (See page 80.)	
1/4" smooth lagging - Hardness 60 ±5 Shore A	o
1/4" diamond lagging - Hardness 60 ±5 Shore A	o
White smooth rubber lagging (FDA). Oil, fat & grease resistant	o
Special lagging (e.g. hot vulcanized)	o
Electromagnetic brake Min. RL increases by 3.94"	x
Mechanical backstop Min. RL does not increase with backstop option	x
Modified for vertical mounting	o
Modified for mounting between 5° and 90° (e.g. for magnetic separators)	o
Insulation class F with standard oil: (Allowable ambient temperature -13°F/+104°F)	Std.
Insulation class H with synthetic oil: (Allowable ambient temperature -13°F/+120°F)	x
Special motors for applications with no belt contact	o
Low noise drives for noise sensitive areas	x
Parallel shell (i.e. no crown)	x
Thermal protector	Std.
IP66/67 Yellow powder coated aluminum terminal box	Std.
IP66/67 Gray powder coated aluminum terminal box (food grade approved)	x
IP66/67 Compact powder coated aluminum terminal box (food grade approved) ≤ 5.5 HP only	o
IP66/67 Compact stainless steel terminal box - AISI 304 or 316 range ≤ 5.5 HP only	o
Straight or elbow connector with standard power cord ≤ 5.5 HP only	x
Straight connector with screened power cord (See page 86 for VFD precautions.) ≤ 5.5 HP only	x
Straight connector with power cord (Stainless steel in AISI 304 range) ≤ 5.5 HP only	x
Voltage: ≤ 5.5 HP dual voltage (230/460) stator (YY/Y winding) wired for 460v/3ph/60 Hz at terminal box	Std.
≤ 5.5 HP dual voltage (230/460) stator (YY/Y winding) wired for 230v/3ph/60 Hz at terminal box	x
7.5 HP single voltage (460) stator (Y winding) wired for 460v/3ph/60 Hz at terminal box	Std.
7.5 HP single voltage (230) stator (YY winding) wired for 230v/3ph/60 Hz at terminal box	x
2 speed motors	x
Special voltage motors	x
Single phase motors	o
CSA approved motors	x

= Optional extras

= An option with certain limitations. Please refer to Technical precautions pages 76-86

= Fitted as standard



Motorized Pulley 220M & 220H, Ø 8.50 in. (216 mm)

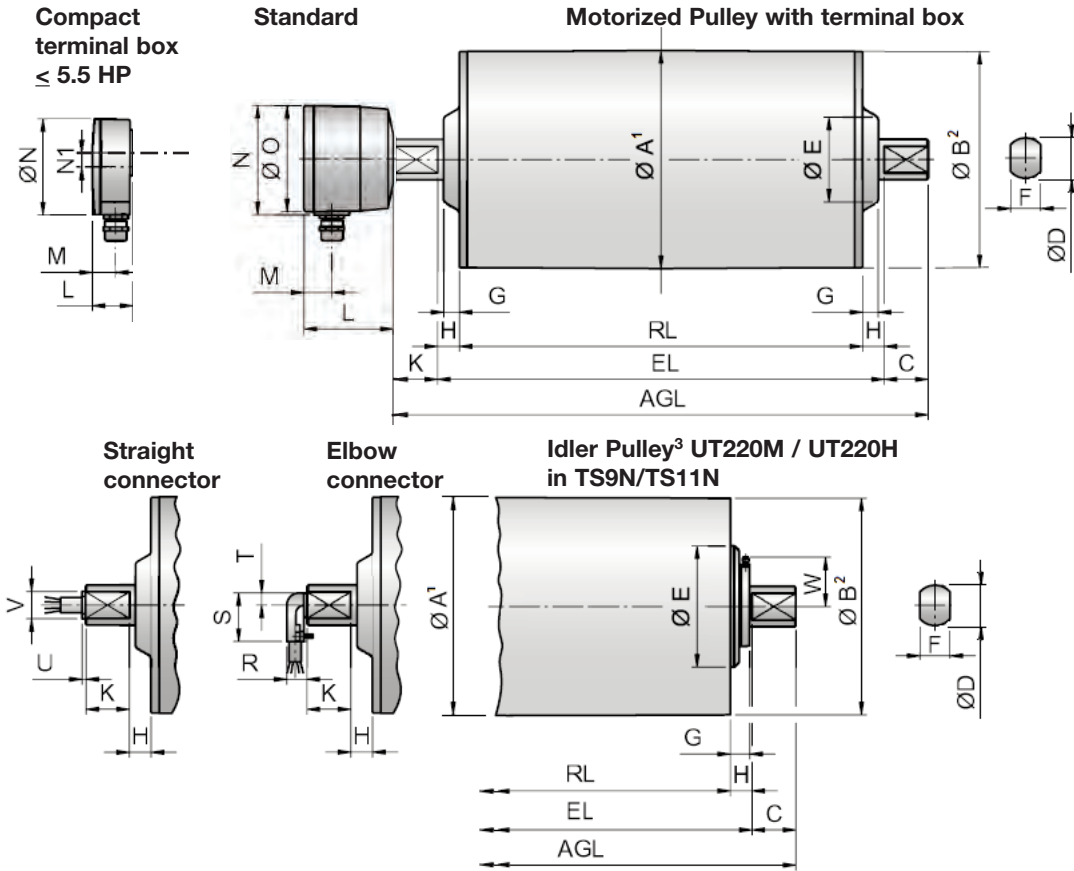

Model	Motorized Pulley or Idler Pulley											Standard terminal box				Compact terminal box ≤ 5.5 HP				Straight connector ≤ 5.5 HP		Elbow connector ≤ 5.5 HP		
	A	B	C	D	E	F	G	G	H	K	W	L	M	N	O	L	M	N	N1	U	V	R	S	T
	in	in	in	in	in	in	in	TS9/11 in	in	in	in	in	in	in	in	in	in	in	in	in	in	in	in	in
220M & 220H	8.50	8.44	1.71	1.57	3.94	1.18	0.61	0.77	0.85	1.63	-	3.43	1.06	4.21	4.13	1.61	0.95	3.74	0.55	0.16	1.06	0.79	1.89	0.47
UT220M & UT220H	8.50	8.50	1.71	1.57	3.94	1.18	0.61	0.77	0.85	-	2.05													

- 1 A dimension is outer diameter of unlagged pulley shell at pulley centerline.
- 2 B dimension is outer diameter of unlagged pulley shell at each end of shell.
- 3 Idler pulley shown is non-crowned TS9N/TS11N version with regreasable seals.

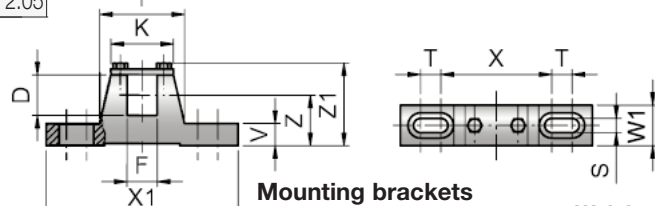

Motorized Pulleys	Material	Bracket Size	Part Number	Dimensions												Weight	
				D	F	I	K	S	T	V	W1	X	X1	Z	Z1		
Model				in	in	in	in	in	in	in	in	in	in	in	in	in	lbs
220M & 220H	Steel painted	KL41-HD	6YA0K	1.57	1.18	3.31	2.44	0.55	0.79	0.87	1.57	4.33	7.48	1.97	3.27	4.63	
	Steel Ni plated		6YA0W														
	Stainless steel		6YA0U														



Motorized Pulley 220M & 220H, Ø 8.50 in. (216 mm) 60

Motor		No. Gear Stages	Model	Nominal belt speed ¹ at Full Load 60 Hz fpm	Actual belt speed ¹ at Full Load 60 Hz fpm	Belt Pull ² lbs	Max. Radial Load ³ T1 + T2 lbs	Min. RL in	RL Dimension inches (RL>78.74" available on request) Weight in lbs ⁵										Type of Bracket
Power HP	No. of Poles								15.75	17.72	19.69	21.65	23.62	25.59	27.56	29.53	31.50	longer than 31.50	
0.50	8	3	220H	30 38	34 40	458 383	5620	17.72	-	146*	154	160	168	175	182	189	196	See Foot-note ⁴	KL41-HD 6YA0K
		2	220M	48 60 76 96 120 150 192 240 300	54 69 84 101 128 159 208 250 319	287 227 185 155 122 97 75 62 49	2585	15.75	111*	117	125	132	139	146	154	160	168		
0.75	8	3	220H	30 38	34 40	685 577	5620	19.69	-	-	163	169	177	183	191	198	205	See Foot-note ⁴	KL41-HD 6YA0K
		2	220M	48 60 76 96 120 150 192 240 300	54 69 84 101 128 159 208 250 319	430 337 277 231 181 146 112 93 73	2585	17.72	-	126	134	140	148	155	162	169	177		
1	8	3	220H	24 30 38	28 34 40	1137 928 774	5620	19.69	-	-	163*	169	177	183	191	198	205	See Foot-note ⁴	KL41-HD 6YA0K
		2	220M	48 60 76 96 120 150 192 240 300	54 69 84 101 128 159 208 250 319	583 460 376 314 247 198 152 126 99	2585	17.72	-	126*	134	140	148	155	162	169	177		
1.5	6	3	220H	30 38 48	37 46 54	1251 1021 852	5620	19.69	-	-	156	163	170	177	184	191	199	See Foot-note ⁴	KL41-HD 6YA0K
		2	220M	60 76	72 91	641 506	2585	17.72	-	122*	129	136	144	150	158	165	172		
	4	2	220M	96 120 150 192 240 300 384 480 600	108 137 168 201 256 319 415 501 637	427 337 276 230 180 145 111 93 73	2585	15.75	106*	113	121	127	135	141	149	156	163		

Idler Pulley		Model	Weight	Min. RL	15.75	17.72	19.69	21.65	23.62	25.59	27.56	29.53	31.50	longer than 31.50	Type of Bracket
		Model UT220M	2585	15.75	60	65	70	74	80	84	90	94	99	See Foot-note ⁴	KL41-HD 6YA0K
		Model UT220H	5620	15.75	64	69	74	79	84	89	94	98	104		

- Use "nominal belt speed" to specify pulley. "Actual belt speed" is presented (for pulley lagged with 1/4" thick rubber) to assist with process design calculations. See Technical Precautions page 77. Note that "actual belt speed" decreases when lagging is not used due to decreased pulley diameter.
 - Belt pull value allows for gearbox loss.
 - Pulley must not be subjected to radial load exceeding "Maximum radial load" defined above. See "Belt Tension" section in Technical Precautions, page 78.
 - Additional Motorized Pulley and Idler Pulley weight, specified per Roller Length:
 $31.50" \leq RL < 59.06" \text{ Wt} = 3.7 \text{ lbs/in}$
 $59.06" \leq RL < 78.74" \text{ Wt} = 7.1 \text{ lbs/in}$
 - All weights shown above are for pulleys with 1/4" thick lagging. To calculate unlagged pulley weight subtract 0.3 lbs/in of Roller Length from above.
- * Special "Short Roller Length" Option



Motorized Pulley 220M & 220H, Ø 8.50 in. (216 mm) 60

Motor		No. Gear Stages	Model	Nominal belt speed ¹ at Full Load 60 Hz fpm	Actual belt speed ¹ at Full Load 60 Hz fpm	Belt Pull ² lbs	Max. Radial Load ³ T1 + T2 lbs	Min. RL in	RL Dimension inches (RL > 78.74" available on request)										Type of Bracket																			
Power HP	No. of Poles								Weight in lbs ⁵																													
										15.75	17.72	19.69	21.65	23.62	25.59	27.56	29.53	31.50	longer than 31.50																			
	6	3	220H	48 60	55 68	1137 928	5620	19.69	-	-	156	163	170	177	184	191	199			See Foot-note ⁴	KL41-HD 6YA0K																	
		2	220M	76	91	690	2585	17.72	-	126*	134	140	148	155	162	169	177																					
2	4	2	220M	96	108	583	2585	15.75	110*	117	125	132	139	146	154	160	164																					
				120	137	460																																
				150	168	376																																
				192	201	314																																
				240	256	247																																
				300	319	198																																
3	4	2	220M	384	415	152	2585	17.72	-	126*	134	140	148	155	162	169	177																					
				480	501	126																																
				600	637	99																																
				96	108	855												2585	17.72			-	126*	134	140	148	155	162	169	177								
				120	137	675																																
				150	168	551																																
192	201	460																																				
240	256	361																																				
300	319	291																																				
4	4	2	220M	384	415	223	2585	19.69	-	-	138	145	153	159	167	173	181																					
				480	501	252																																
				600	637	197																																
				96	104	1216												2585	19.69	-	-	-	169	177	183	191	198	201										
				120	129	978																																
				150	168	751																																
192	201	627																																				
240	256	492																																				
300	319	396																																				
5.5	2	3	220H	120	136	1237	5620	21.65	-	-	-	169	177	183	191	198	205																					
				150	163	1033																																
				192	216	777												2585	19.69	-	-	138	145	153	159	167	173	181										
		240	274	614																																		
		300	336	501																																		
		7.5	2	3	220H	384												408	567	5620	21.65	-	-	-	169	177	183	191	198	205								
480	522					443																																
600	625					370																																

Idler Pulley	Model UT220M	2585	15.75	59	65	70	74	80	84	90	94	99	See Foot-note ⁴	KL41-HD 6YA0K
		Model UT220H	5620	15.75	63	69	74	79	84	89	94	98		

- Use "nominal belt speed" to specify pulley. "Actual belt speed" is presented (for pulley lagged with 1/4" thick rubber) to assist with process design calculations. See Technical Precautions page 77. Note that "actual belt speed" decreases when lagging is not used due to decreased pulley diameter.
 - Belt pull value allows for gearbox loss.
 - Pulley must not be subjected to radial load exceeding "Maximum radial load" defined above. See "Belt Tension" section in Technical Precautions, page 78.
 - Additional Motorized Pulley and Idler Pulley weight, specified per Roller Length:
 $31.50" \leq RL < 59.06" \text{ Wt} = 3.7 \text{ lbs/in}$
 $59.06" \leq RL < 78.74" \text{ Wt} = 7.1 \text{ lbs/in}$
 - All weights shown above are for pulleys with 1/4" thick lagging. To calculate unlagged pulley weight subtract 0.3 lbs/in of Roller Length from above.
- * Special "Short Roller Length" Option



Motorized Pulley 220M, Ø 8.50 in. (216 mm)

Spare parts list and sectional drawings

Pos.	Description	Pos.	Description	Pos.	Description
1	Shell	14	Rear shaft	52	Magnetic oil plug
1.1	Shell (ss option)	14.1	Rear shaft (ss option)	52.1	Magnetic oil plug (ss option)
2	End housing with geared rim	14.2	Rear shaft (short RL option)	53	Distance washer
2.1	End hsg w/geared rim (ss option)	15	Stator complete	53.1	Compression nipple
3	End housing	15.1	Rotor	59	Countersunk head screw
3.1	End housing (ss option)	16	Terminal box complete	66	Waved spring washer
8	Geared rim	17	Nipple	68	Key
9	Rotor pinion	20	Cover	70	Toothed washer
10	Input wheel	20.1	Cover with labyrinth groove	78	Gasket
11	Output pinion	23	Rear flange	79	Holding clip or plastic tie
12	Gear box	23.1	rear flange for backstop	85.1	Intermediate flange for brake
13	Front shaft	23.2	Rear flange for Brake	91	Electromagnetic brake
13.1	Front shaft (ss option)	24.1	Shaft oil seal outer	93	Retaining ring
		24.2	Shaft oil seal inner	95	Straight connector
		24.3	Shaft oil seal (lab option)	96	Elbow connector
		25	O-ring	101	Key
		26	Bearing	104	Distance washer
		27	Bearing	120	Labyrinth cover
		28	Bearing	121	Set screw
		29	Bearing	122	O-ring
		29.1	Bearing (Backstop option)	123	Grease nipple
		30	Bearing	124	Distance washer
		31	Bearing	140	Deflection seal
		39	Hexagon socket screw	143	O-ring
		40	Hexagon socket screw	146	Special compression washer
		41	Hexagon socket screw	200	Rubber seal

Compact Terminal Box

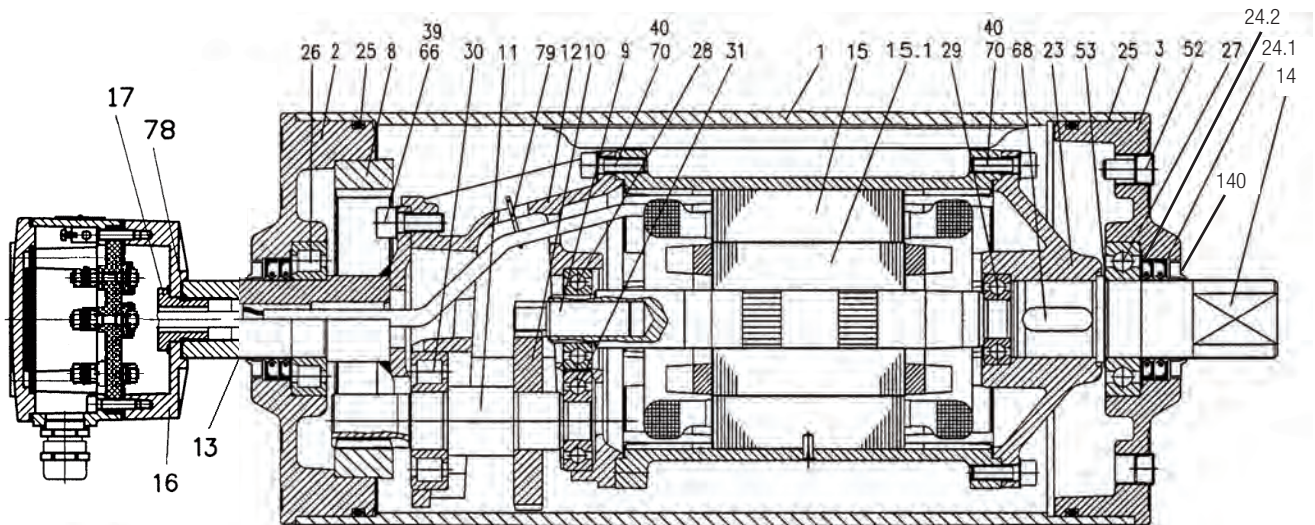
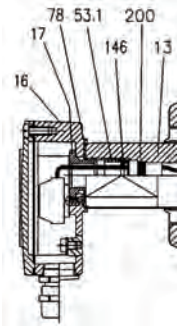



Motorized Pulley 220H, Ø 8.50 in. (216 mm)

Spare parts list and sectional drawings

Pos.	Description	Pos.	Description	Pos.	Description
1	Shell	16	Terminal box complete	85.1	Intermediate flange for brake
1.1	Shell (ss option)	17	Nipple	91	Electromagnetic brake
2	End housing with geared rim	20	Cover	93	Retaining ring
2.1	End hsg w/geared rim (ss option)	20.1	Cover with labyrinth groove	95	Straight connector
3	End housing	23	Rear flange	96	Elbow connector
3.1	End housing (ss option)	23.1	Rear flange (backstop option)	101	Key
8	Geared rim	23.2	Rear flange (int. brake option)	104	Distance washer
9	Rotor pinion	24.1	Shaft oil seal outer	120	Labyrinth cover
10	Input wheel	24.2	Shaft oil seal inner	121	Set screw
11	Output pinion	24.3	Shaft oil seal (lab option)	122	O-ring
12	Gear box	25	O-ring	123	Grease nipple
13	Front shaft	26	Bearing	124	Distance washer
13.1	Front shaft (ss option)	27	Bearing	140	Defection seal
14	Rear shaft	28	Bearing	143	O-ring
14.1	Rear shaft (ss option)	29	Bearing	146	Special compression washer
14.2	Rear shaft (short RL option)	29.1	Bearing (Backstop option)	180	Intermediate pinion
15	Stator complete	30	Bearing	181	Intermediate wheel
15.1	Rotor	31	Bearing	182	Distance washer
		40	Hexagon socket screw	184	Roller bearing
		41	Hexagon socket screw	185	Roller bearing
		52	Magnetic oil plug	186	Key
		52.1	Magnetic oil plug (ss option)	187	Key
		53	Distance washer	188	Spring washer
		53.1	Compression nipple	190	Spring washer
		59	Countersunk head screw	191	Spring washer
		66	Waved spring washer	194	Set screw
		68	Key	196	Key
		70	Toothed washer	197	Spring washer
		78	Gasket	198	Distance washer
		79	Holding clip or plastic tie	200	Rubber seal

Intermediate Shaft

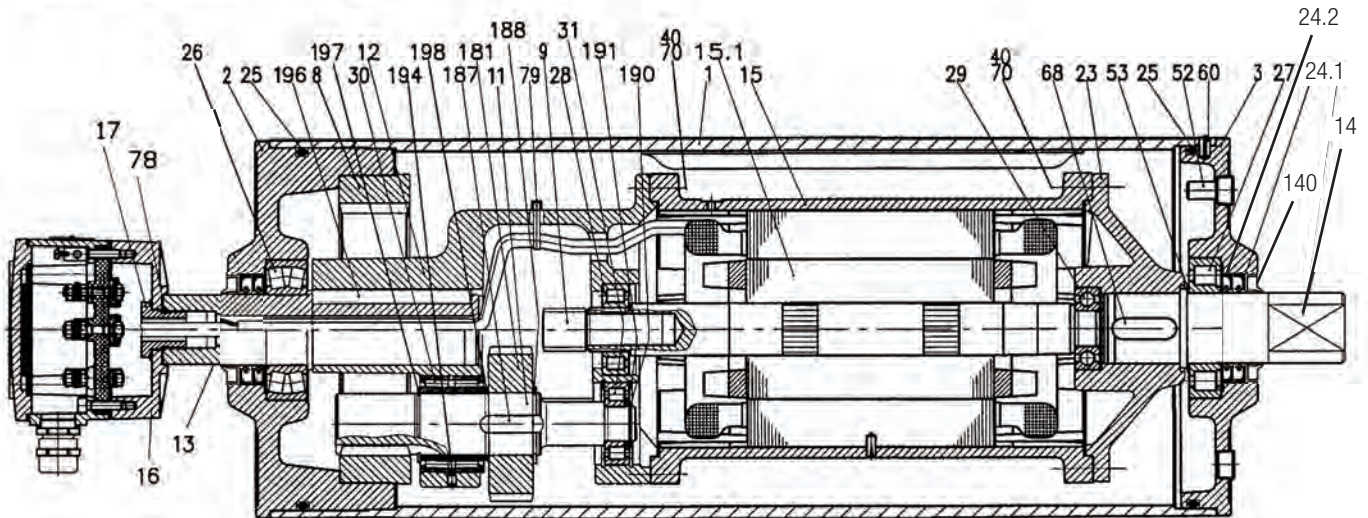
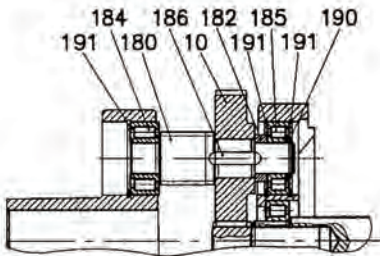



Motorized Pulley 220M & 220H, Ø 8.50 in. (216 mm)

Sectional drawings (See parts list on pages 23 & 24.)

Straight Connector

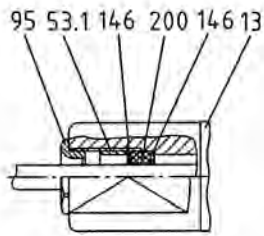

Elbow Connector

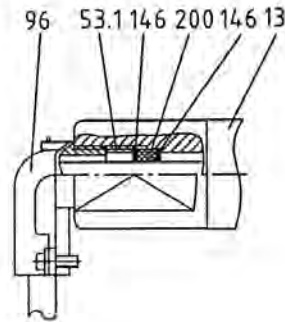

Electromagnetic Brake Option

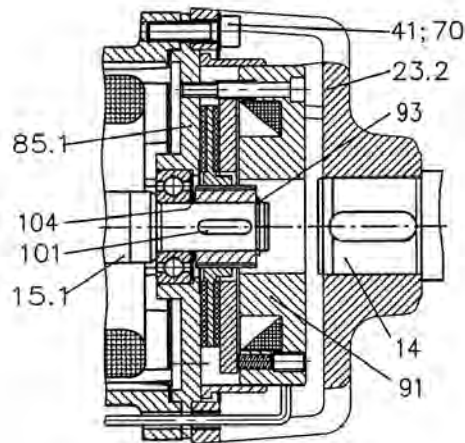

Mechanical Backstop Option

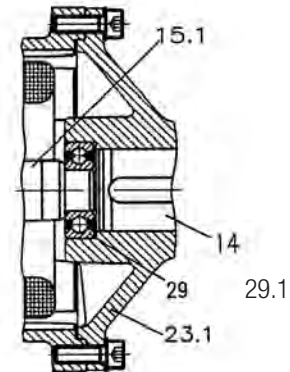

Short Roller Length Option

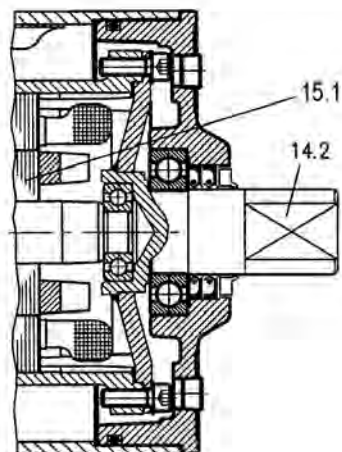

Carbon Steel Shell & Shaft with Labyrinth Option

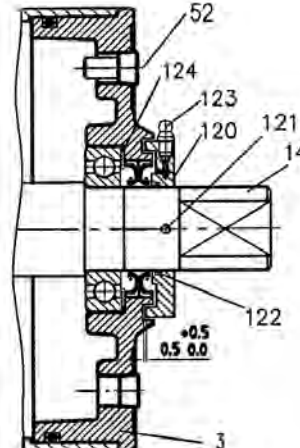



Motorized Pulley 220M & 220H, Ø 8.50 in. (216 mm)

Sectional drawings (See parts list on pages 23 & 24.)

Stainless Steel with Labyrinth Options TS9N
(Position 1 for carbon steel shell valid for TS11N only.)

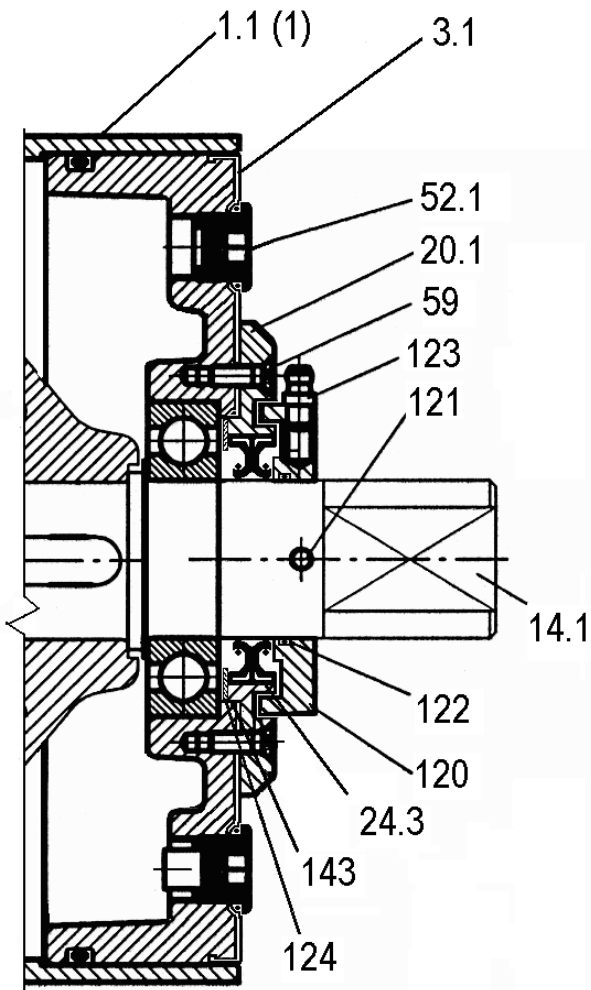

Stainless Steel Non-Labyrinth Options TS10N
(Position 1 for carbon steel shell valid for TS12N only.)

