



Motorized Pulley 400L, 400M & 400H, Ø 15.91 in. (404 mm)

Our 15.91" diameter Motorized Pulley range offers three different performance levels for BULK applications:

- L for Light duty
- M for Medium duty
- H for Heavy duty

It is important to note the product differences and choose the appropriate pulley based on estimated belt tension (radial load.) See page 78. The actual radial load must be less than the maximum allowable radial load shown in this catalog.

Be aware of increased belt tensions required to drive multi-ply thick heavy belts and/or larger belt widths.

If the 15.91" diameter model is not strong enough to resist estimated belt tension, then select 19.72" diameter model.

L for Light duty

400L is designed for regular and continuous operating conditions. It is advisable to rubber lag these pulleys to grip the belt and limit belt tension. A popular application is self-cleaning magnetic separators. 400L uses motor and gearbox from 320M.

M for Medium duty

400M is designed for tough and irregular operating conditions. 400M is typically used in heavy mobile crushing & screening applications as well as in crushed stone, ore, cement, steel, and fertilizer handling.

H for Heavy duty

A solid 3-stage gearbox enables the 400H to provide low speed at high torque and handle irregular loadings in harsh operating conditions.

STANDARD SPECIFICATION of Motorized Pulley

- Crowned mild steel 15.91" diameter steel shell painted yellow at a minimum thickness of 2.4 mils
- Bolted powder coated cast iron bearing housings and covers, all painted yellow at a minimum thickness of 2.4 mils
- Mild steel shafts treated w/anti-rust wax
- Shaft sealing system - degree of protection IP66/67 (EN60034-5.) See pg 88.
- Powder coated aluminum terminal box for 400L
- Cast iron terminal box for 400M & 400H painted yellow at min.thickness of 2.4 mils
- 3-phase induction motors with thermal protector
- Voltage: All common voltages available. Please specify.
- Motor winding insulation Class F
- Dynamically balanced rotor
- Two oil plugs each fitted with a magnet to filter the oil
- Oil change recommended every 10,000 operational hours
- Minimum RL. Refer to pages 43-44
- Maximum RL - Please inquire
- Non standard RL's available
- To be used in horizontal positions ±5 degree only

Please note:

- **Noise-sensitive Areas:** High speed 2-pole motors can cause higher noise levels and are not recommended for noise-sensitive areas
- **Technical Precautions for Design, Installation, and Maintenance:** pages 76-86
- **Environmental Considerations:** pg 72
- **Optional Extras:** pg 41 and back cover
- **Electrical Connection Diagrams:** pages 94-96.

STAINLESS STEEL options

TS9N

- Stainless steel shell - AISI 304 range
- Stainless steel shafts - AISI 303/4 range
- Stainless steel covered bearing housings - AISI 316 range
- Regreasable bearing covers with labyrinth grooves and labyrinth seals with grease nipples in stainless steel - AISI 304 range

- Stainless steel oil plugs - AISI 304 range - one out of two with magnet
- Stainless steel exterior bolts - AISI 304 range
- Shaft sealing system - degree of protection IP66/67 (EN60034-5) See pg 88

TS10N

- As TS9, but without regreasable labyrinth seals

SEMI-RUST-FREE options

TS 11N

- Painted mild steel shell - min. thickness of 4.7 mils
- Stainless steel shafts - AISI 303/4 range
- Stainless steel covered cast iron bearing housing - AISI 316 range
- Regreasable bearing covers with labyrinth grooves and grease nipples in stainless steel - AISI 304 range
- Stainless steel oil plugs - AISI 304 range - one out of two with magnet
- Stainless steel exterior bolts - AISI 304 range
- Shaft sealing system - degree of protection IP66/67 (EN60034-5)
- Powder coated terminal box for 400L
- Painted terminal box - min. thickness of 4.7 mils for 400M & 400H

TS12N

- As TS11N, but without regreasable seals.
- Covers - standard

Other Stainless Options:

- FDA & USDA food grade recognized oil and grease are not included in TS9N - TS12N, but available on request
- Complete Motorized Pulleys in acid resistant stainless steel - AISI 316 range - available on request.
- Special mounting brackets available

Electrical connection options:

- Salt water resistant powder coated aluminum terminal box with zinc plated exterior bolts
- Stainless steel terminal box - AISI 304 range (400L ≤ 5.5 HP only)
- Straight stainless steel connector with flying lead - AISI 304 range ≤ 5.5 HP only.

Please specify required TS-number when ordering Stainless Steel options..



OPTIONAL EXTRAS

Motorized Pulley 400L, 400M & 400H

Specification	Availability	
Total stainless steel option AISI 304 range	TS9N with regreasable labyrinth seals	x
Total stainless steel option AISI 304 range	TS10N with standard seals	x
Semi-rust free option	TS11N with regreasable labyrinth seals	x
Semi-rust free option	TS12N with standard seals	x
Regreasable labyrinth seals		x
Food grade oil & grease - FDA & USDA recognized		x
Dust explosion proof Motorized Pulleys - ATEX 95 - Zone 22 - for applications handling of dusty grain etc. According to European Directive 94/9/EC.		x
Total acid resistant stainless steel option - AISI 316 range		x
Black rubber lagging - Standard specifications (See page 80.)		
5/16" full diamond lagging - Hardness 60 ±5 Shore A	≤ 15 HP	o
5/16" partial diamond lagging - Hardness 60 ±5 Shore A	20 HP	o
White smooth rubber lagging (FDA listed) - Oil, fat & grease resistant		o
Special lagging (e.g. hot vulcanized)		o
Electromagnetic brake	Min RL increases by 3.94"	x
Mechanical backstop	Min. RL increases by 1.97" for 400L	x
	Min. RL = 29.53" for 400M	x
	Min. RL = 31.50" for 400H	x
Modified for vertical mounting		o
Modified for mounting between 5° and 90°		o
Insulation class F with standard oil: (Allowable ambient temperature -13°F/+104°F)		Std.
Insulation class H with synthetic oil: (Allowable ambient temperature -13°F/+120°F)		x
Special motors for applications with no belt contact		o
Low noise drives for noise sensitive areas		x
Parallel shell (i.e. no crown)		x
Thermal protector		Std.
IP66/67 Standard yellow powder coated aluminum terminal box	400L	Std.
IP66/67 Optional gray powder coated aluminum terminal box (food grade approved)	400L	x
IP66/67 Standard yellow powder coated cast iron terminal box	400M & 400H	Std.
Straight or elbow connector with standard power cord	≤ 5.5 HP only	x
Straight connector with screened power cord (See page 86 for VFD precautions)	≤ 5.5 HP only	x
Straight connector with power cord (Stainless steel in AISI 304 range)	≤ 5.5 HP only	x
Voltage: ≤ 5.5 HP dual voltage (230/460) stator (YY/Y winding) wired for 460v/3ph/60 Hz at terminal box		Std.
≤ 5.5 HP dual voltage (230/460) stator (YY/Y winding) wired for 230v/3ph/60 Hz at terminal box		x
≥ 7.5 HP single voltage (460) stator (Y winding) wired for 460v/3ph/60 Hz at terminal box		Std.
≥ 7.5 HP single voltage (230) stator (YY winding) wired for 230v/3ph/60 Hz at terminal box		x
2 speed motors		x
Special voltage motors		x
CSA approved motors		x

= Optional extras

= An option with certain limitations. Please refer to Technical precautions pages 76-86.

= Fitted as standard



Motorized Pulley 400L, 400M & 400H, Ø 15.91 in. (404 mm)

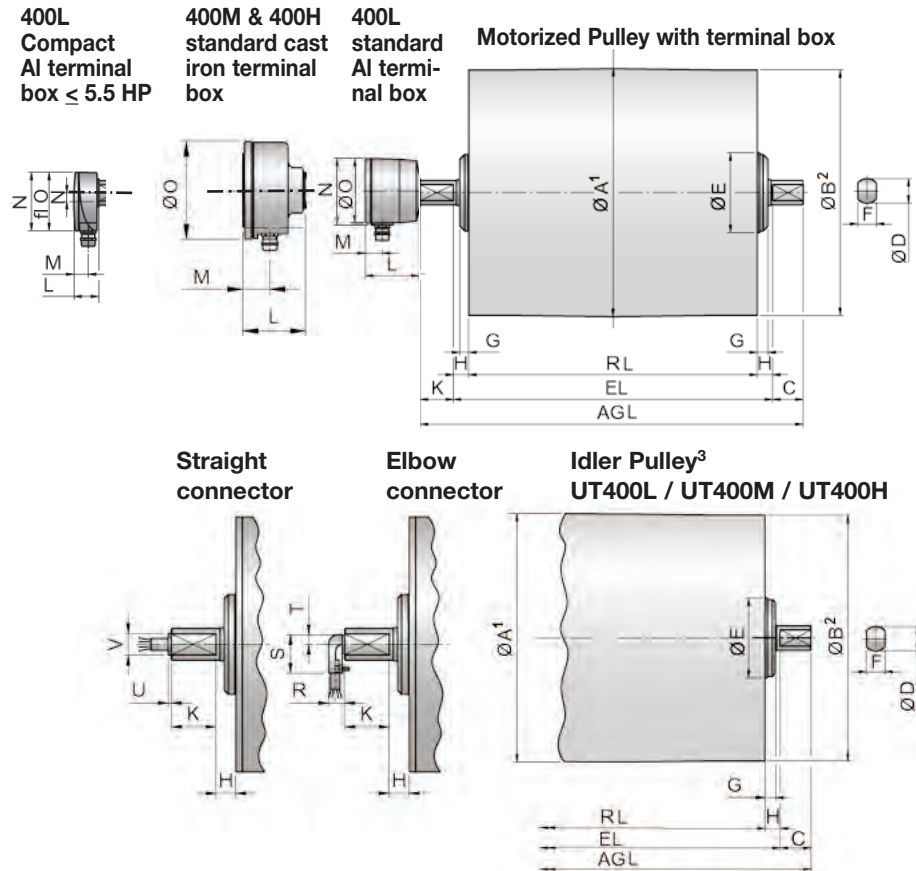

Model	Motorized Pulley or idler Pulley									Standard terminal box				Compact terminal box $\le 5.5\text{ HP}$				Straight connector $\le 5.5\text{ HP}$		Elbow connector $\le 5.5\text{ HP}$		
	A in	B in	C in	D in	E in	F in	G in	H in	K in	L in	M in	N in	O in	L in	M in	N in	N1 in	U in	V in	R in	S in	T in
400L	15.91	15.75	1.97	1.57	4.92	1.18	0.79	0.98	2.13	3.43	1.06	4.21	4.13	1.61	0.95	3.74	0.55	0.16	1.06	0.79	1.89	0.47
400M & 400H	15.91	15.75	1.97	2.36	7.64	1.77	0.91	0.98	1.97	3.94	1.44	-	6.14	3.94	1.44	-	-	-	-	-	-	-
UT400L	15.91	15.91	1.97	1.57	4.92	1.18	0.67	0.98	-	-	-	-	-	-	-	-	-	-	-	-	-	-
UT400M & UT400H	15.91	15.91	1.97	2.36	6.61	1.77	0.79	0.98	-	-	-	-	-	-	-	-	-	-	-	-	-	-

- 1 A dimension is outer diameter of unlagged pulley shell at pulley centerline.
- 2 B dimension is outer diameter of unlagged pulley shell at each end of shell.
- 3 Idler pulley shown is non-crowned TS9N/TS11N version with regreasable seals.

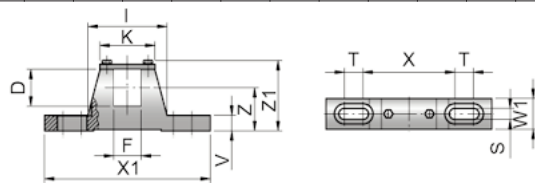

Motorized Pulleys	Material	Bracket Size	Part Number	Dimensions												Weight
				D in	F in	I in	K in	S in	T in	V in	W1 in	X in	X1 in	Z in	Z1 in	
400L	Steel painted	KL4-HD	6YA0K	1.57	1.18	3.31	2.44	0.55	0.79	0.87	1.57	4.33	7.48	1.97	3.27	4.63
	Steel Ni plated		6YA0W													
	Stainless steel		6YA0U													
400M & 400H	Steel painted	KL60	6YA09	2.36	1.77	5.12	3.54	0.71	1.18	0.98	1.97	5.91	10.63	2.76	4.53	10.58
	Steel Ni plated		6YA0D													



Motorized Pulley 400L, Ø 15.91 in. (404 mm) 60 Hz

Motor			Model	Nominal belt speed ¹ at Full Load 60 Hz fpm	Actual belt speed ¹ at Full Load 60 Hz fpm	Belt Pull ² lbs	Max. Radial Load ³ T1 + T2 lbs	Min. RL in	RL Dimension inches (RL>78.74" available on request) Weight in lbs ⁵											Type of Bracket
Power HP	No. of Poles	No. Gear Stages							19.69	21.65	23.62	25.59	27.56	29.53	31.50	33.46	35.43	37.40	longer than 37.40	
3	4	2	400L	192	201	460	4496	19.69	276*	288	300	312	324	337	349	361	373	385	See Foot-note ⁴	KL41-HD 6YA0K
				240	240	385														
				300	303	305														
				384	395	234														
				480	498	186														
600	613	151																		
4	4	2	400L	150	163	771	4496	19.69	276*	288	300	312	324	337	349	361	373	385	See Foot-note ⁴	KL41-HD 6YA0K
				192	201	627														
				240	240	524														
				300	303	416														
				384	395	319														
480	498	253																		
600	613	206																		
5.5	4	2	400L	192	201	836	4496	19.69	298*	310	322	334	346	359	371	383	395	407	See Foot-note ⁴	KL41-HD 6YA0K
				240	240	700														
				300	303	554														
				384	395	425														
				480	498	338														
600	613	274																		
7.5	4	2	400L	300	303	778	4496	19.69	298*	310	322	334	346	359	371	383	395	407	See Foot-note ⁴	KL41-HD 6YA0K
				384	395	598														
				480	498	474														
				600	613	386														
10	2	2	400L	384	402	784	4496	19.69	298*	310	322	334	346	359	371	383	395	407	See Foot-note ⁴	KL41-HD 6YA0K
				480	481	655														
				600	607	520														
				768	791	399														

Idler Pulley			Model UT400L	4496	19.69	188	200	212	224	236	249	261	273	285	297	See Foot-note ⁴	KL41-HD 6YA0K

- 1 Use "nominal belt speed" to specify pulley. "Actual belt speed" is presented (for pulley lagged with 5/16" thick rubber) to assist with process design calculations. See Technical Precautions page 77. Note that "actual belt speed" decreases when lagging is not used due to decreased pulley diameter.
- 2 Belt pull value allows for gearbox loss.
- 3 Pulley must not be subjected to radial load exceeding "Maximum radial load" defined above. See "Belt Tension" section in Technical Precautions, page 78.
- 4 Additional Motorized Pulley and Idler Pulley weight, specified per Roller Length: $37.40 \leq RL \leq 78.74$ Wt = 6.2 lbs/in.
- 5 All weights shown above are for pulleys with 5/16" thick lagging. To calculate unlagged pulley weight subtract 0.6 lbs/in of Roller Length from above.
- * Special "Short Roller Length" Option



Motorized Pulley 400M & 400H, Ø 15.91 in. (404 mm) 60

Motor		No. Gear Stages	Model	Nominal belt speed ¹ at Full Load 60 Hz fpm	Actual belt speed ¹ at Full Load 60 Hz fpm	Belt Pull ² lbs	Max. Radial Load ³ T1 + T2 lbs	Min. RL in	RL Dimension inches (RL>78.74" available on request) Weight in lbs ⁵										Type of Bracket
Power HP	No. of Poles								23.62	25.59	27.56	29.53	31.50	33.46	35.43	37.40	39.37	longer than 39.37	
3	8	3	400H	38 48 60	44 54 64	2121 1725 1442	11,250	25.59	-	533	547	563	577	591	605	619	634	See Foot-note ⁴	KL60 6YA09
		2	400M	76 96 120 150 192 240 300 384	82 101 121 152 197 248 307 390	1131 920 770 610 468 371 302 238	9,100	23.62	442	456	470	485	500	514	528	542	557		
5.5	8	3	400H	48 60 76	54 64 81	3137 2623 2079	11,250	25.59	-	553	567	582	597	611	625	639	654		
		2	400M	96 120 150 192 240 300 384	101 121 152 197 248 307 390	1673 1399 1108 851 675 548 432	9,100	23.62	462	476	490	505	519	534	548	562	576		
7.5	4	3	400H	76 96 120	87 107 128	2651 2156 1803	11,250	25.59	-	533	547	563	577	591	605	619	634		
		2	400M	150 192 240 300 384 480 600 768	163 201 240 303 395 498 613 778	1413 1150 962 762 585 465 377 297	9,100	23.62	442	456	470	485	500	514	528	542	557		
10	6	3	400H	96 120 150	108 140 177	2923 2244 1782	11,250	29.53	-	-	-	602	616	631	645	659	673		
	4	2	400M	192 240 300 384 480 600 768	201 240 303 395 498 613 778	1568 1311 1039 798 633 515 405	9,100	23.62	455	469	483	499	513	527	541	556	570		
15	4	3	400H	150 192 240	162 211 265	2859 2194 1742	11,250	29.53	-	-	-	602	616	631	645	659	673		
		2	400M	300 384 480 600 768	303 395 498 613 778	1525 1170 929 754 594	9,100	27.56	-	-	510*	525	539	554	568	582	596		
20	2	3	400H	192 240 300	214 257 323	2940 2459 1949	11,250	29.53	-	-	-	602	616	631	645	659	673		
		2	400M	384 480 600 768	402 481 607 791	1568 1311 1039 798	9,100	27.56	-	-	510*	525	539	554	568	582	596		

Idler Pulley	UT400M	9,100	23.62	264	277	294	309	323	333	347	362	376	See Foot-note ⁴	KL60 6YA09
	UT400H	11,250	25.59	-	288	305	320	334	344	358	373	387		

- Use "nominal belt speed" to specify pulley. "Actual belt speed" is presented (for pulley lagged with 5/16" thick rubber) to assist with process design calculations. See Technical Precautions page 77. Note that "actual belt speed" decreases when lagging is not used due to decreased pulley diameter.
 - Belt pull value allows for gearbox loss.
 - Pulley must not be subjected to radial load exceeding "Maximum radial load" defined above. See "Belt Tension" section in Technical Precautions, page 78.
 - Additional Motorized Pulley and Idler Pulley weight, specified per Roller Length: $39.37 \leq RL \leq 78.74$ Wt = 7.3 lbs/in.
 - All weights shown above are for pulleys "fully lagged" with 5/16" thick rubber. For "partially lagged" pulleys add 5% to 10% to the weights shown above. See page 80 for "partial lagging." To calculate unlagged pulley weight subtract 0.6 lbs/in of Roller Length from above.
- * Special "Short Roller Length" Option



Motorized Pulley 400L, Ø 15.91 in. (404 mm)

Spare parts list and sectional drawings

Pos.	Description	Pos.	Description	Pos.	Description
1	Shell	24.3	Shaft oil seal outer (lab option)	68	Key
1.1	Shell (ss option)	24.4	Shaft oil seal inner (lab option)	73	Set screw
2	End housing with geared rim	26	Bearing	75	Gasket
2.1	End housing (ss option)	27	Bearing	76	Gasket
3	End housing	28	Bearing	77	Gasket
3.1	End housing (ss option)	29	Bearing	78	Gasket
8	Geared rim	30	Bearing	79	Holding clip or plastic tie
9	Rotor pinion	31	Bearing	85	Intermediate flange for backstop
10	Input wheel	32	Retaining ring	85.1	Intermediate flange for brake
11	Output pinion	33	Retaining ring	90	Backstop
12	Gear box – cast aluminum	37	Hexagon socket screw	91	Electromagnetic brake
13	Front shaft	38	Hexagon socket screw	93	Retaining ring
13.1	Front shaft (ss option)	43	Hexagon screw	94	Hexagon head screw
14	Rear shaft	44	Hexagon screw	95	Straight connector
14.1	Rear shaft (ss option)	45	Hexagon socketed head screw	96	Elbow connector
15	Stator complete	46	Hexagon screw	99	Waved spring washer
15.1	Rotor	49	Washer	101	Key
16	Terminal box complete	50	Washer	104	Distance washer
17	Nipple	52	Magnetic oil plug	120	Labyrinth cover
20	Cover – front side	52.1	Magnetic plug (ss option)	121	Set screw
20.1	Cover with labyrinth groove	53	Distance washer	122	O-ring
21	Cover – rear side	53.1	Compression nipple	123	Grease nipple
21.1	Cover with labyrinth groove	60	Parallel pin	140	Deflection seal
23	Rear flange	64	Prevailing torque type hex nut	143	O-ring
24.1	Shaft oil seal outer	66	Waved spring washer	146	Special compression washer
24.2	Shaft oil seal inner	67	Waved spring washer	200	Rubber seal

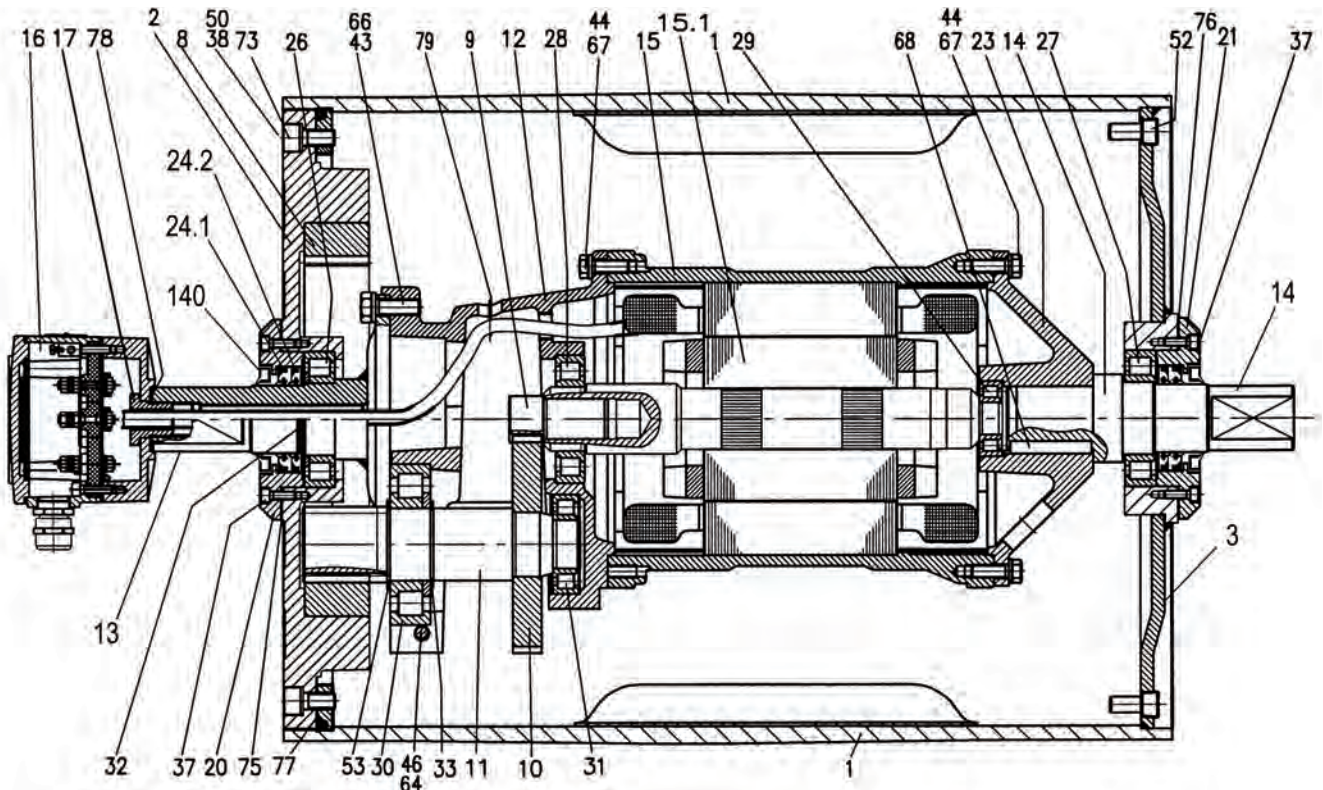



Motorized Pulley 400M, Ø 15.91 in. (404 mm)

Spare parts list and sectional drawings

Pos.	Description	Pos.	Description	Pos.	Description
1	Shell	23	Rear flange	66	Waved spring washer
1.1	Shell (ss option)	24.1	Shaft oil seal outer	67	Waved spring washer
2	End housing with geared rim	24.2	Shaft oil seal inner	70	Spring washer
2.1	End housing (ss option)	24.3	Shaft oil seal outer (lab option)	73	Set screw
3	End housing	24.4	Shaft oil seal inner (lab option)	75	Gasket
3.1	End housing (ss option)	26	Bearing	76	Gasket
8	Geared rim	27	Bearing	77	Gasket
9	Rotor pinion	28	Bearing	78	Gasket
10	Input wheel	29	Bearing	85	Intermediate flange
11	Output pinion	30	Bearing	90	Backstop
12	Gear box – cast aluminum	31	Bearing	91	Electromagnetic brake
13	Front shaft	32	Retaining ring	93	Retaining ring
13.1	Front shaft (ss option)	36	Hexagon head screw	94	Hexagon head screw
14	Rear shaft	45	Hexagon screw	99	Waved spring washer
14.1	Rear shaft (ss option)	50	Waved spring washer	101	Key
15	Stator complete	52	Magnetic oil plug	104	Distance washer
15.1	Rotor	52.1	Magnetic oil plug (ss option)	120	Labyrinth cover
16	Terminal box complete	37	Hexagon socket screw	121	Set screw
17	Nipple	38	Hexagon socket screw	122	O-ring
20	Cover – front side	43	Hexagon screw	123	Grease nipple
20.1	Cover with labyrinth groove	44	Hexagon screw	140	Deflection seal
21	Cover – rear side	52	Magnetic oil plug		
21.1	Cover with labyrinth groove	53	Distance washer		

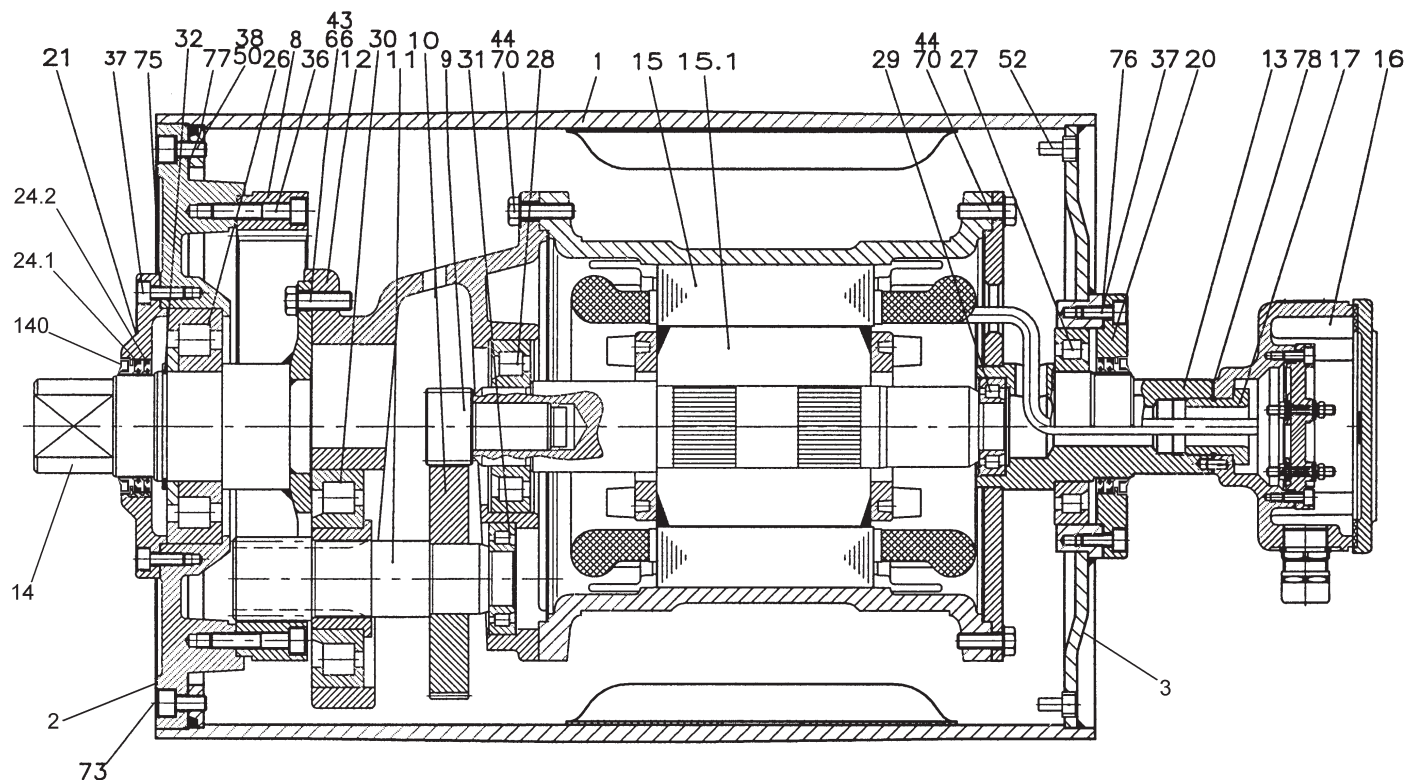



Motorized Pulley 400H, Ø 15.91 in. (404 mm)

Spare parts list and sectional drawings

Pos.	Description	Pos.	Description	Pos.	Description
1	Shell	28	Bearing	76	Gasket
1.1	Shell (ss option)	30	Bearing	77	Gasket
2	End housing with geared rim	31	Bearing	78	Gasket
2.1	End housing (ss option)	32	Retaining ring	85	Intermediate flange for brake
3	End housing	33	Retaining ring	90	Backstop
3.1	End housing (ss option)	36	Hexagon socket screw	91	Electromagnetic brake
8	Geared rim	37	Hexagon socket screw	93	Retaining ring
9	Rotor pinion	38	Hexagon socket screw	94	Hexagon head screw
10	Input wheel	43	Hexagon socket screw	99	Waved spring washer
11	Output pinion	44	Hexagon socket screw	101	Key
12	Gear box – cast iron	45	Hexagon socket screw	104	Distance washer
13	Front shaft	50	Waved spring washer	120	Labyrinth cover
13.1	Front shaft (ss option)	52	Magnetic oil plug	121	Set screw
14	Rear shaft	52.1	Magnetic oil plug (ss option)	122	O-ring
14.1	Rear shaft (ss option)	53	Distance washer	123	Grease nipple
15	Stator complete	66	Waved spring washer	140	Deflection seal
15.1	Rotor	72	Taper grooved pin	180	Intermediate pinion shaft
16	Terminal box complete	73	Set screw	181	Intermediate wheel
17	Nipple	75	Gasket	182	Distance washer
20	Cover Front side			183	Distance washer
20.1	Cover with labyrinth groove			184	Roller bearing
21	Cover rear side			185	Roller bearing
21.1	Cover with labyrinth groove			186	Key
23	Rear flange			187	Key
24.1	Shaft oil seal outer			188	Retaining ring
24.2	Shaft oil seal inner			190	Retaining ring
24.3	Shaft oil seal outer (lab option)			191	Retaining ring
24.4	Shaft oil seal inner (lab option)			194	Set screw
26	Bearing			196	Key
27	Bearing			197	Retaining ring

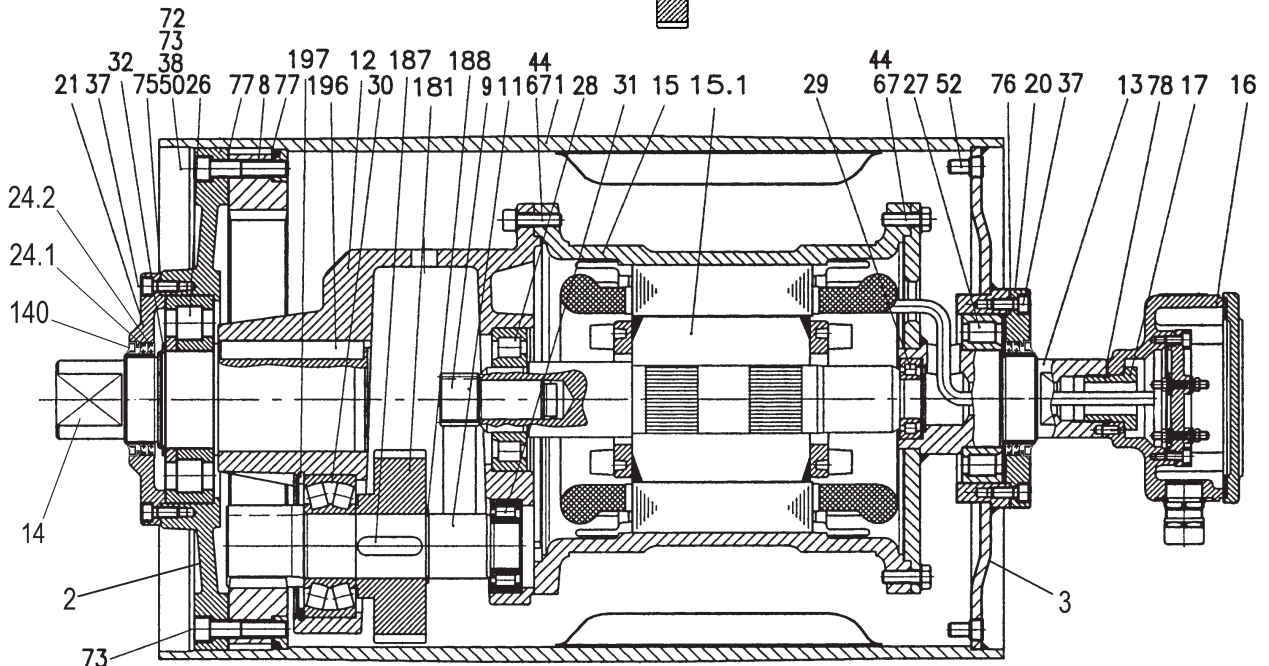
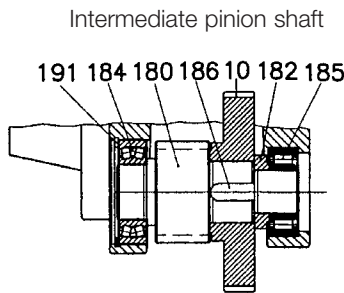



Motorized Pulley 400L, 400M & 400H, Ø 15.91 in. (404 mm)

Sectional drawings

Backstop Option (valid for 400M & 400H)

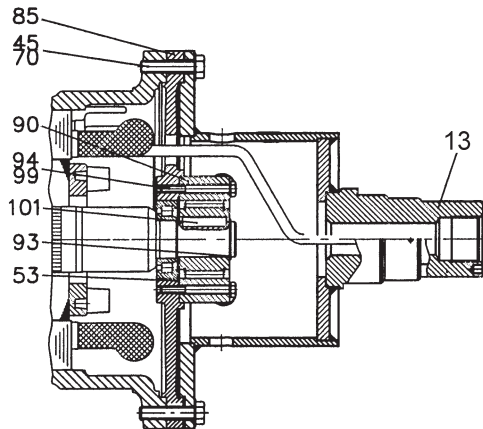

Electromagnetic Brake Option (valid for 400M & 400H)

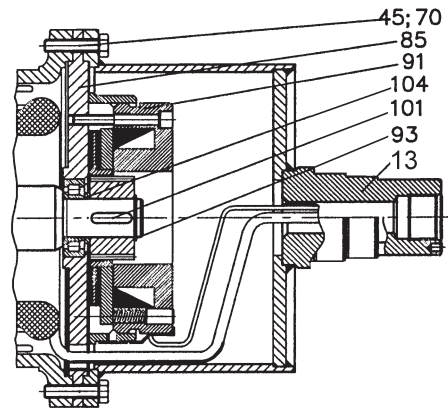

Backstop Option (valid for 400L)

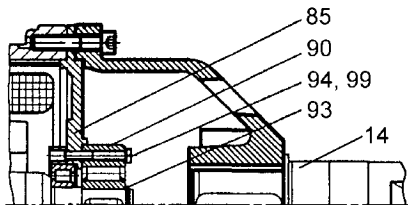

Stainless Steel with Labyrinth Options TS9N
(Position 1 for carbon steel shell valid for TS11N only)

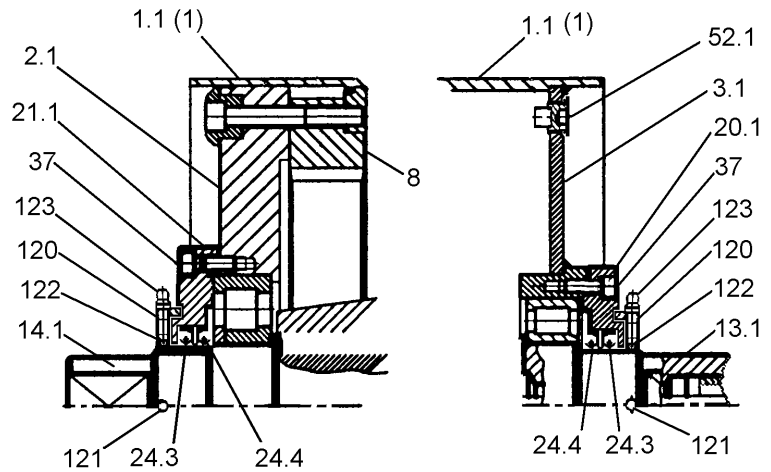

Electromagnetic Brake Option (valid for 400L)

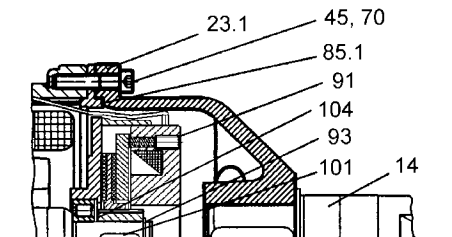

Stainless Steel Non-Labyrinth Options TS10N
(Position 1 for carbon steel shell valid for TS12N only)

