



Motorized Pulley 220M & 220H, Ø 8.50 in. (216 mm)

Our 8.50" diameter Motorized Pulley range offers two different performance levels for BULK applications:

- M for Medium duty
- H for Heavy duty

It is important to note the product differences and choose the appropriate pulley based on estimated belt tension (radial load.) See page 82. The actual radial load must be less than the maximum allowable radial load shown in this catalog.

Be aware of increased belt tensions required to drive multi-ply thick heavy belts and/or larger belt widths.

If the 8.50" diameter model is not strong enough to resist estimated belt tension, then select 12.64" diameter model.

M for Medium duty

The internal parts of 220M are designed to match irregular working conditions in applications such as mobile crushing & screening, cement & concrete plants, mobile conveyors and open stone & gravel pits.

H for Heavy duty

A reinforced 3-stage-gearbox provides 220H with the necessary strength needed for low speeds and high torque. 220H is popular in recycling (hand sorter conveyors), bunker discharge conveyors and where a combination of slow speed and high torque is required.

STANDARD SPECIFICATION of Motorized Pulley

- Crowned mild steel 8.50" diameter steel shell treated with anti-rust wax
- Powder coated cast iron bearing housings
- Mild steel shafts treated with anti-rust wax
- Shaft sealing system - degree of protection IP66/67 (EN60034-5.) See page 37.
- Powder coated die cast aluminum terminal box
- 3-phase induction motors with thermal protector
- Voltage: All common voltages available. Please specify.
- Motor winding insulation Class F
- Dynamically balanced rotor
- Two oil plugs fitted with magnets to filter the oil
- Oil change recommended every 50,000 operational hours for synthetic oil and 10,000 operational hours for standard oil.
- Minimum RL. Please refer to pages 21-22
- Maximum RL – Please inquire
- Non standard RL's available
- To be used in horizontal positions ± 5 degree only

Please note:

- **Noise-sensitive Areas:** High speed 2-pole motors can cause higher noise levels and are not recommended for noise-sensitive areas
- **Technical Precautions for Design, Installation, and Maintenance:** pages 80-90
- **Environmental Considerations:** pages 78-79
- **Optional Extras:** pg 19
- **Electrical Connection Diagrams:** pages 94-101

STAINLESS STEEL options

TS9N

- Stainless steel shell – AISI 304 range
- Stainless steel shafts – AISI 303/4 range
- Stainless steel covered bearing housings – AISI 316 range
- Stainless steel oil plugs – AISI 304 range – one out of two with magnet
- Stainless steel exterior bolts – AISI 304 range
- Regreasable labyrinth seals with grease nipples in stainless steel – AISI 304 range
- Shaft sealing system – degree of protection IP66/67 (EN60034-5).

TS10N

- As TS9N, but without regreasable labyrinth seals.

SEMI-RUST-FREE options

TS11N

- As TS9N, but with crowned mild steel shell treated with anti-rust wax.

TS12N

- As TS10N, but with crowned mild steel shell treated with anti-rust wax.

Other Stainless Options:

- FDA & USDA food grade recognized oil and grease are not included in TS9N to TS12N, but available on request
- Complete Motorized Pulleys in acid resistant stainless steel – AISI 316 range – available on request.
- Special mounting brackets are available

Electrical connection options:

- Salt water resistant powder coated aluminum terminal box with zinc plated exterior bolts
- Stainless steel terminal box – AISI 304 range (max. 5.5 HP)
- Straight stainless steel connector with flying lead – AISI 304 range.

Please specify required TS-number when ordering Stainless Steel options.



OPTIONAL EXTRAS

Motorized Pulley 220M & 220H

Specification	Availability
Total stainless steel option AISI 304 range TS9N with regreasable labyrinth seals	x
Total stainless steel option AISI 304 range TS10N with standard seals	x
Semi-rust free option TS11N with regreasable labyrinth seals	x
Semi-rust free option TS12N with standard seals	x
Regreasable labyrinth seals	x
Food grade oil & grease - FDA & USDA recognized	x
Dust explosion proof Motorized Pulleys - ATEX 95 - Zone 22 - for applications handling of dusty grain etc. According to European Directive 94/9/EC.	x
Total acid resistant stainless steel option - AISI 316	x
Black rubber lagging - Standard specifications (See page 80.)	
1/4" smooth lagging - Hardness 60 ±5 Shore A	o
1/4" diamond lagging - Hardness 60 ±5 Shore A	o
White smooth rubber lagging (FDA). Oil, fat & grease resistant	o
Special lagging (e.g. hot vulcanized)	o
Electromagnetic brake Min. RL increases by 3.94"	x
Mechanical backstop Min. RL does not increase with backstop option	x
Modified for vertical mounting	o
Modified for mounting between 5° and 90° (e.g. for magnetic separators)	o
Insulation class F with standard oil: (Allowable ambient temperature -13°F/+104°F)	Std.
Insulation class H with synthetic oil: (Allowable ambient temperature -13°F/+120°F)	x
Special motors for applications with no belt contact	o
Low noise drives for noise sensitive areas	x
Parallel shell (i.e. no crown)	x
Thermal protector	Std.
IP66/67 Yellow powder coated aluminum terminal box	Std.
IP66/67 Compact powder coated aluminum terminal box (food grade approved) < 5.5 HP only	o
IP66/67 Compact stainless steel terminal box - AISI 304 or 316 range < 5.5 HP only	o
Straight or elbow connector with standard power cord < 5.5 HP only	x
Straight connector with screened power cord (See page 77 for VFD precautions.) < 5.5 HP only	x
Straight connector with power cord (Stainless steel in AISI 304 range) < 5.5 HP only	x
Voltage: < 5.5 HP dual voltage (230/460) stator (YY/Y winding) wired for 460v/3ph/60 Hz at terminal box	Std.
< 5.5 HP dual voltage (230/460) stator (YY/Y winding) wired for 230v/3ph/60 Hz at terminal box	x
7.5 HP single voltage (460) stator (Y winding) wired for 460v/3ph/60 Hz at terminal box	Std.
7.5 HP single voltage (230) stator (YY winding) wired for 230v/3ph/60 Hz at terminal box	x
2 speed motors	x
Special voltage motors	x
Single phase motors	o
CSA approved motors	x

x = Optional extras
o = An option with certain limitations. Please refer to Technical precautions pages 80-90.
Std. = Fitted as standard



Motorized Pulley 220M & 220H, Ø 8.50 in. (216 mm)

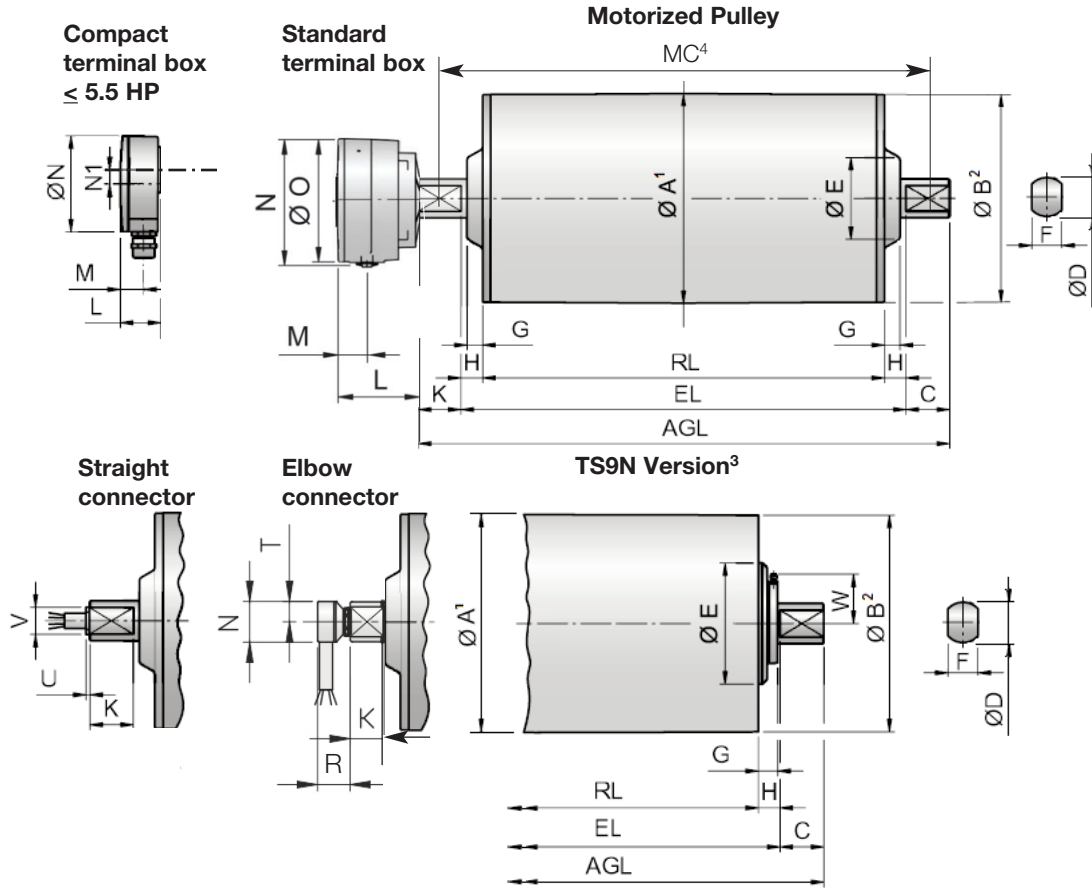

Version	Dimensions										Standard terminal box					Compact terminal box ⁵					Straight connector ⁵			Elbow connector ⁵			
	A	B	C	D	E	F	G	H	W	K	L	M	N	O	K	L	M	N	N1	K	U	V	K	N	R	T	
Standard	8.50	8.44	1.71	1.57	3.94	1.18	0.61	0.85	-	1.63	3.43	1.06	5.08	5.04	1.63	1.61	0.95	3.74	0.55	1.71	0.16	1.06	1.71	1.18	0.98	0.59	
TS9N	8.50	8.44	1.71	1.57	3.94	1.18	0.77	0.85	2.05	1.63	3.43	1.06	5.08	5.04	1.63	1.61	0.95	3.74	0.55	1.71	0.16	1.06	1.71	1.18	0.98	0.59	

- 1 A dimension is outer diameter of crowned unlagged pulley shell at pulley centerline.
- 2 B dimension is outer diameter of crowned unlagged pulley shell at each end of shell.
- 3 Pulley shown is TS9N version with regreasable seals.
- 4 Mounting centers = MC = RL + W1.
- 5 These connection options are only available in Motorized Pulleys at 5.5 HP and less.

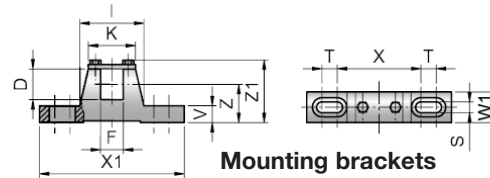

Motorized Pulleys	Material	Bracket Size	Part Number	Dimensions												Weight
				D in	F in	I in	K in	S in	T in	V in	W1 in	X in	X1 in	Z in	Z1 in	
220M & 220H	Steel painted	KL41-HD	6YA0K	1.57	1.18	3.31	2.44	0.55	0.79	0.87	1.57	4.33	7.48	1.97	3.27	4.63
	Steel Ni plated		6YA0W													
	Stainless steel		6YA0U													



Motorized Pulley 220M & 220H, Ø 8.50 in. (216 mm) 60 Hz

Motor		No. Gear Stages	Model	Nominal belt speed ¹ at Full Load 60 Hz fpm	Actual belt speed ¹ at Full Load 60 Hz fpm	Belt Pull ² lbs	Max. Radial Load ³ T1 + T2 lbs	Min. RL in	RL Dimension inches (RL>78.74" available on request)										Type of Bracket			
Power HP	No. of Poles								Weight in lbs ⁵													
										15.75	17.72	19.69	21.65	23.62	25.59	27.56	29.53	31.50	longer than 31.50			
0.50	8	3	220H	30 38	34 40	458 383	5620	17.72	-	146*	154	160	168	175	182	189	196					
		2	220M	48 60 76 96 120 150 192 240 300	54 69 84 101 128 159 208 250 319	287 227 185 155 122 97 75 62 49	2585	15.75	111*	117	125	132	139	146	154	160	168					
0.75	8	3	220H	30 38	34 40	685 577	5620	19.69	-	-	163	169	177	183	191	198	205					
		2	220M	48 60 76 96 120 150 192 240 300	54 69 84 101 128 159 208 250 319	430 337 277 231 181 146 112 93 73	2585	17.72	-	126	134	140	148	155	162	169	177					
1	8	3	220H	24 30 38	28 34 40	1137 928 774	5620	19.69	-	-	163*	169	177	183	191	198	205			See Foot-note ⁴	KL41-HD 6YA0K	
		2	220M	48 60 76 96 120 150 192 240 300	54 69 84 101 128 159 208 250 319	583 460 376 314 247 198 152 126 99	2585	17.72	-	126*	134	140	148	155	162	169	177					
1.5	6	3	220H	30 38 48	37 46 54	1251 1021 852	5620	19.69	-	-	156	163	170	177	184	191	199					
		2	220M	60 76	72 91	641 506	2585	17.72	-	122*	129	136	144	150	158	165	172					
	4	2	220M	96 120 150 192 240 300 384 480 600	108 137 168 201 256 319 415 501 637	427 337 276 230 180 145 111 93 73	2585	15.75	106*	113	121	127	135	141	149	156	163					

← Special RL | Standard RL →

- 1 Use "nominal belt speed" to specify pulley. "Actual belt speed" is presented (for pulley lagged with 1/4" thick rubber) to assist with process design calculations. See Technical Precautions page 81. Note that "actual belt speed" decreases when lagging is not used due to decreased pulley diameter.
 - 2 Belt pull value allows for gearbox loss on a lagged pulley.
 - 3 Pulley must not be subjected to radial load exceeding "Maximum radial load" defined above. See "Belt Tension" section in Technical Precautions, page 82.
 - 4 Additional Motorized Pulley weight, specified per Roller Length:
 $31.50" \leq RL < 59.06"$ Wt = 3.7 lbs/in
 $59.06" \leq RL < 78.74"$ Wt = 7.1 lbs/in
 - 5 All weights shown above are for pulleys with 1/4" thick lagging. To calculate unlagged pulley weight subtract 0.3 lbs/in of Roller Length from above.
- * Special "Short Roller Length" Option

Rulmeca offers return, snub, and idler pulleys with dimensions to match our Motorized Pulleys on request.



Motorized Pulley 220M & 220H, Ø 8.50 in. (216 mm) 60 Hz

Motor		No. Gear Stages	Model	Nominal belt speed ¹ at Full Load 60 Hz fpm	Actual belt speed ¹ at Full Load 60 Hz fpm	Belt Pull ² lbs	Max. Radial Load ³ T1 + T2 lbs	Min. RL in	RL Dimension inches (RL>78.74" available on request) Weight in lbs ⁵										Type of Bracket
Power HP	No. of Poles								15.75	17.72	19.69	21.65	23.62	25.59	27.56	29.53	31.50	longer than 31.50	
	6	3	220H	48 60	55 68	1137 928	5620	19.69	-	-	156	163	170	177	184	191	199	See Foot-note ⁴ KL41-HD 6YAOK	
		2	220M	76	91	690	2585	17.72	-	126*	134	140	148	155	162	169	177		
2	4	2	220M	96	108	583	2585	15.75	110*	117	125	132	139	146	154	160	164		
				120	137	460													
				150	168	376													
				192	201	314													
				240	256	247													
				300	319	198													
				384	415	152													
480	501	126																	
600	637	99																	
3	4	2	220M	60	68	1361	2585	17.72	-	126*	134	140	148	155	162	169	177		
				76	82	1136													
				96	108	855													
				120	137	675													
				150	168	551													
				192	201	460													
				240	256	361													
300	319	291																	
384	415	223																	
480	501	185																	
600	637	145																	
4	4	2	220M	96	104	1216	2585	19.69	-	-	138	145	153	159	167	173	181		
				120	129	978													
				150	168	751													
				192	201	627													
				240	256	492													
				300	319	396													
				384	415	304													
480	501	252																	
600	637	197																	
5.5	2	2	220M	120	136	1237	2585	19.69	-	-	138	145	153	159	167	173	181		
				150	163	1033													
				192	216	777													
				240	274	614													
				300	336	501													
				384	402	418													
				480	512	329													
600	636	264																	
7.5	2	3	220H	192	202	1146	5620	21.65	-	-	-	169	177	183	191	198	205		
				240	254	909													
				300	314	735													
				384	408	567													
				480	522	443													
				600	625	370													

← Special RL | Standard RL →

- Use "nominal belt speed" to specify pulley. "Actual belt speed" is presented (for pulley lagged with 1/4" thick rubber) to assist with process design calculations. See Technical Precautions page 81. Note that "actual belt speed" decreases when lagging is not used due to decreased pulley diameter.
 - Belt pull value allows for gearbox loss on a lagged pulley.
 - Pulley must not be subjected to radial load exceeding "Maximum radial load" defined above. See "Belt Tension" section in Technical Precautions, page 82.
 - Additional Motorized Pulley weight, specified per Roller Length:
 $31.50" \leq RL < 59.06" \text{ Wt} = 3.7 \text{ lbs/in}$
 $59.06" \leq RL < 78.74" \text{ Wt} = 7.1 \text{ lbs/in}$
 - All weights shown above are for pulleys with 1/4" thick lagging. To calculate unlagged pulley weight subtract 0.3 lbs/in of Roller Length from above.
- * Special "Short Roller Length" Option

Rulmeca offers return, snub, and idler pulleys with dimensions to match our Motorized Pulleys on request.



Motorized Pulley 220M, Ø 8.50 in. (216 mm)

Spare parts list and sectional drawings

Pos.	Description	Pos.	Description	Pos.	Description
1	Shell	14.1	Rear shaft (ss option)	53	Distance washer
1.1	Shell (ss option)	14.2	Rear shaft (short RL option)	53.1	Compression nipple
2	End housing with geared rim	15	Stator complete	59	Countersunk head screw
2.1	End hsg w/geared rim (ss option)	15.1	Rotor	66	Waved spring washer
3	End housing	16	Terminal box complete	68	Key
3.1	End housing (ss option)	17	Nipple	70	Toothed washer
8	Geared rim	20	Cover	78	Gasket
9	Rotor pinion	20.1	Cover with labyrinth groove	79	Holding clip or plastic tie
10	Input wheel	23	Rear flange	85.1	Intermediate flange for brake
11	Output pinion	23.1	rear flange for backstop	91	Electromagnetic brake
12	Gear box	23.2	Rear flange for Brake	93	Retaining ring
13	Front shaft	24.1	Shaft oil seal outer	95	Straight connector
13.1	Front shaft (ss option)	24.2	Shaft oil seal inner	96	Elbow connector
14	Rear shaft	24.3	Shaft oil seal (lab option)	101	Key
		25	O-ring	104	Distance washer
		26	Bearing	120	Labyrinth cover
		27	Bearing	121	Set screw
		28	Bearing	122	O-ring
		29	Bearing	123	Grease nipple
		29.1	Bearing (Backstop option)	124	Distance washer
		30	Bearing	140	Deflection seal
		31	Bearing	143	O-ring
		39	Hexagon socket screw	146	Special compression washer
		40	Hexagon socket screw	200	Rubber seal
		41	Hexagon socket screw	201	O-ring
		52	Magnetic oil plug	223	Cable

Compact Terminal Box

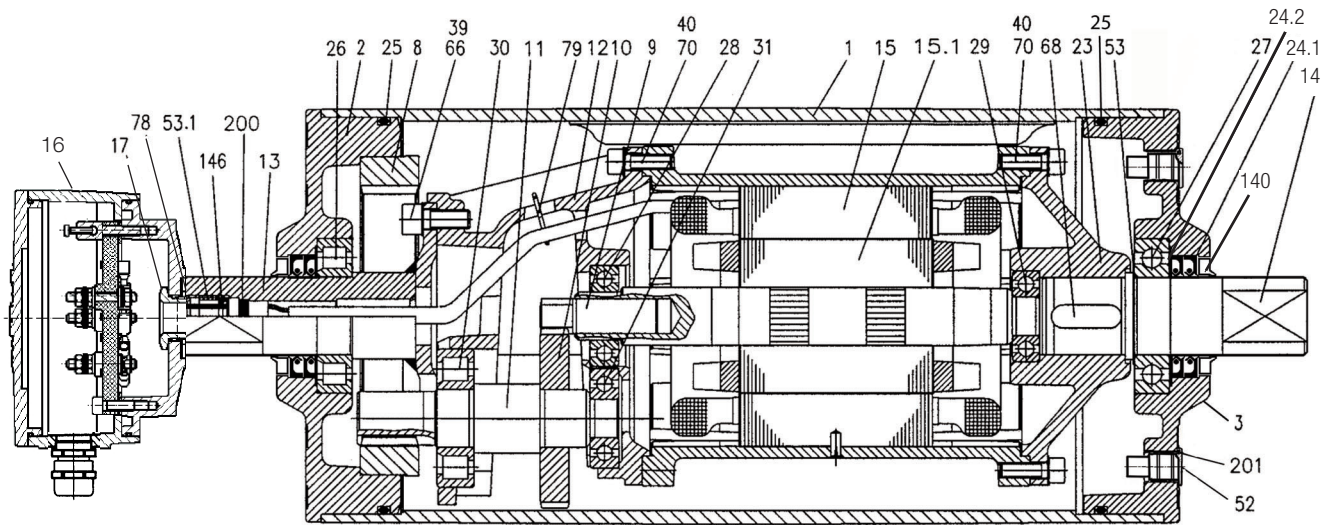
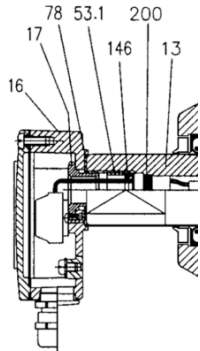



Motorized Pulley 220H, Ø 8.50 in. (216 mm)

Spare parts list and sectional drawings

Pos.	Description	Pos.	Description	Pos.	Description
1	Shell	17	Nipple	93	Retaining ring
1.1	Shell (ss option)	20	Cover	95	Straight connector
2	End housing with geared rim	20.1	Cover with labyrinth groove	96	Elbow connector
2.1	End hsg w/geared rim (ss option)	23	Rear flange	101	Key
3	End housing	23.1	Rear flange (backstop option)	104	Distance washer
3.1	End housing (ss option)	23.2	Rear flange (int. brake option)	120	Labyrinth cover
8	Geared rim	24.1	Shaft oil seal outer	121	Set screw
9	Rotor pinion	24.2	Shaft oil seal inner	122	O-ring
10	Input wheel	24.3	Shaft oil seal (lab option)	123	Grease nipple
11	Output pinion	25	O-ring	124	Distance washer
12	Gear box	26	Bearing	140	Deflection seal
13	Front shaft	27	Bearing	143	O-ring
13.1	Front shaft (ss option)	28	Bearing	146	Special compression washer
14	Rear shaft	29	Bearing	180	Intermediate pinion
14.1	Rear shaft (ss option)	29.1	Bearing (Backstop option)	181	Intermediate wheel
14.2	Rear shaft (short RL option)	30	Bearing	182	Distance washer
15	Stator complete	31	Bearing	184	Roller bearing
15.1	Rotor	40	Hexagon socket screw	185	Roller bearing
16	Terminal box complete	41	Hexagon socket screw	186	Key
		52	Magnetic oil plug	187	Key
		53	Distance washer	188	Spring washer
		53.1	Compression nipple	190	Spring washer
		59	Countersunk head screw	191	Spring washer
		66	Waved spring washer	194	Set screw
		68	Key	196	Key
		70	Toothed washer	197	Spring washer
		78	Gasket	198	Distance washer
		79	Holding clip or plastic tie	200	Rubber seal
		85.1	Intermediate flange for brake	201	O-ring
		91	Electromagnetic brake	223	Cable

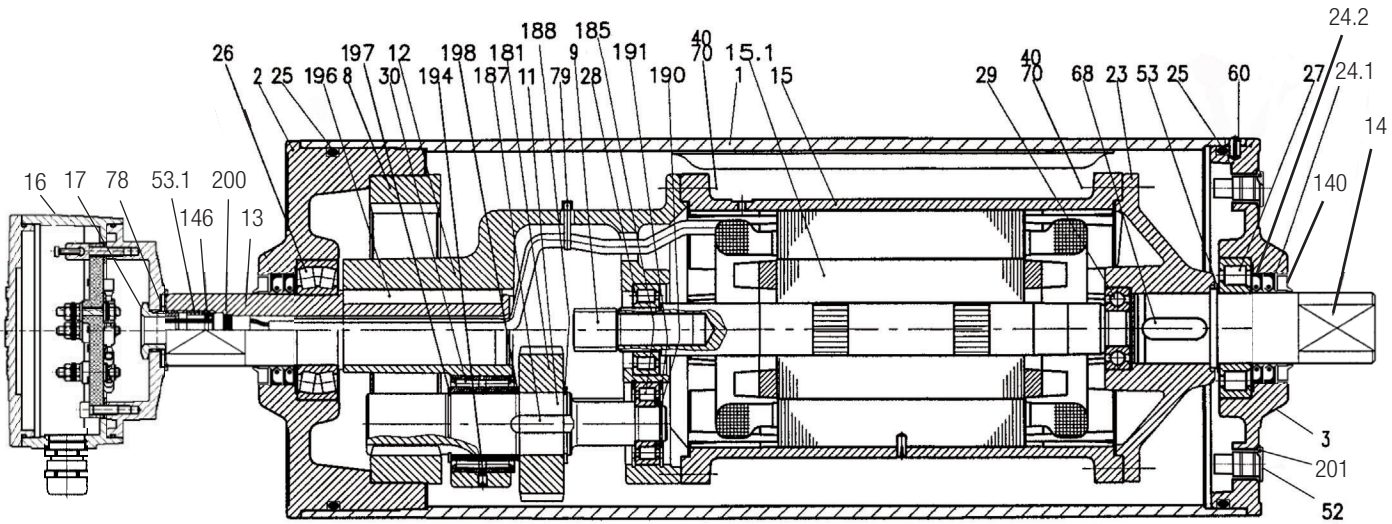
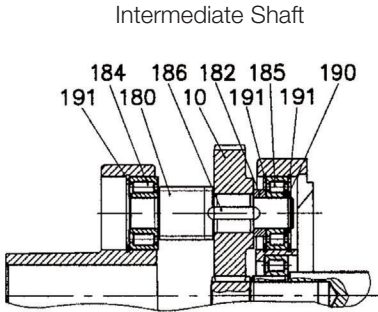



Motorized Pulley 220M & 220H, Ø 8.50 in. (216 mm)

Sectional drawings (See parts list on pages 23 & 24.)

Standard straight cable connection

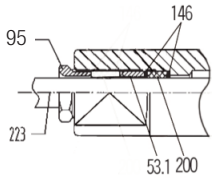

Stainless steel option with straight cable connection

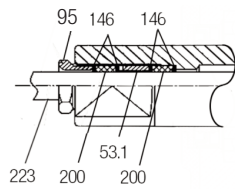

Standard elbow cable connection

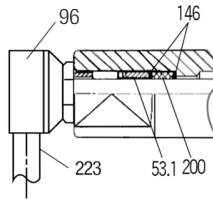

Stainless steel option with elbow cable connection

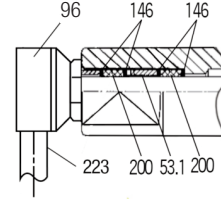

Electromagnetic Brake Option

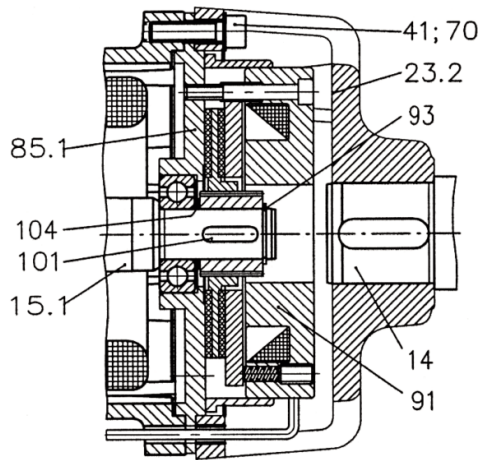

Mechanical Backstop Option

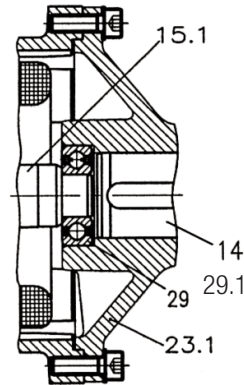

Short Roller Length Option

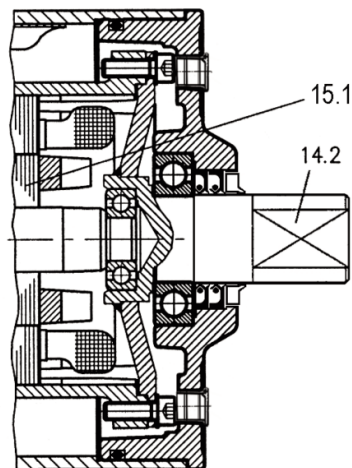

Carbon Steel Shell & Shaft with Labyrinth Option

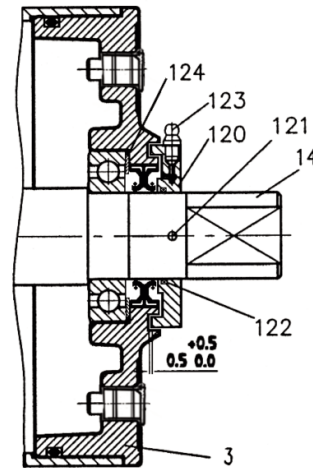



Motorized Pulley 220M & 220H, Ø 8.50 in. (216 mm)

Sectional drawings (See parts list on pages 23 & 24.)

Stainless Steel with Labyrinth Options TS9N
(Position 1 for carbon steel shell valid for TS11N only.)

Stainless Steel Non-Labyrinth Options TS10N
(Position 1 for carbon steel shell valid for TS12N only.)

