



138LS - 165LS Connection Diagrams

Terminal Box - 3 Phase

Dual Voltage - European Motor

Code:

T1 & T2: Thermal protection

B1 & B2: Internal brake

rd - red

ye - yellow

bk - black

gy - gray

bu - blue

gn - green

wh - white

bn - brown

Low Voltage

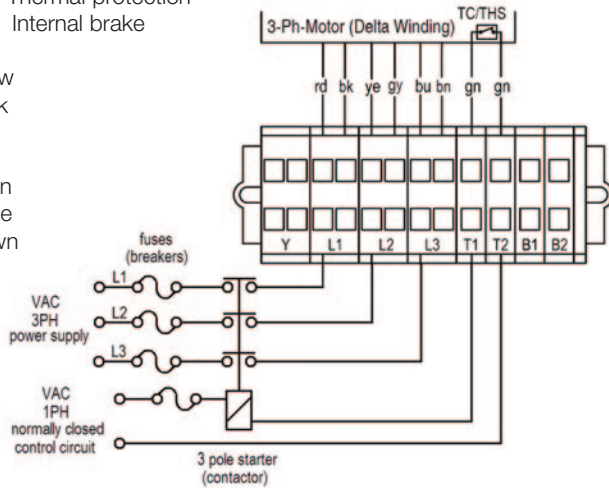

High Voltage

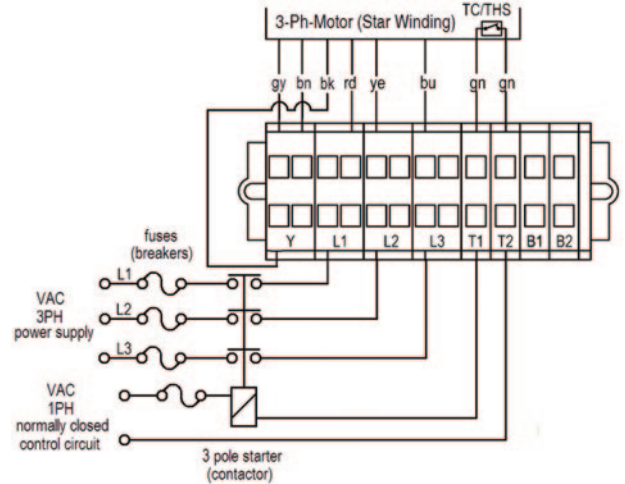

Low Voltage with Brake Option

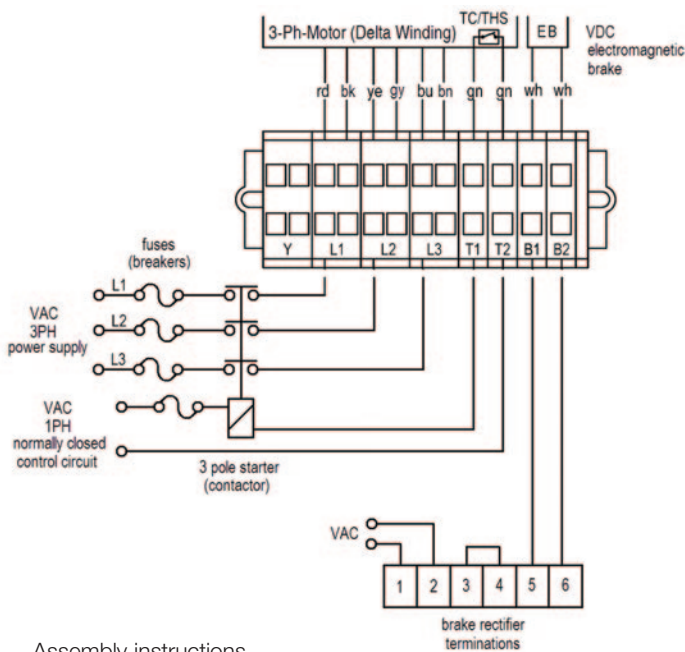

High Voltage with Brake Option

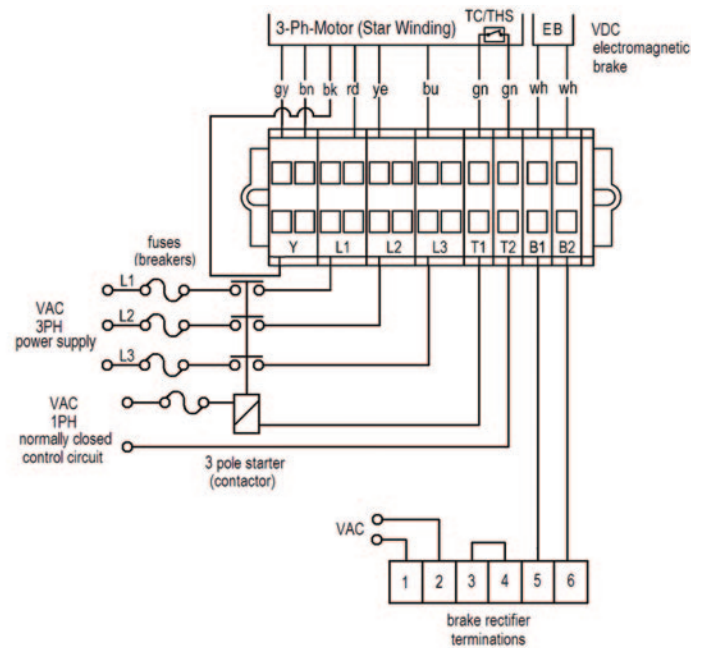

Assembly instructions

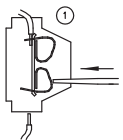

Push down clamp

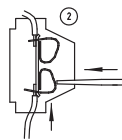

Push in wire

NOTE:

Brake rectifier is shown with jumper across terminals 3 & 4. This enables AC power supply to rectifier to stop and start brake. Brake responsiveness may be improved by connecting an external switch to terminals 3 & 4.