



Motorized Pulley 80LP

Ø 3.37 in. (80 mm), planetary polymer gearbox

Product description

Due to its strength, reliability, and need for no maintenance, this Motorized Pulley is used in small conveyors, packaging machines, and simple transfer units.

Characteristics

- Asynchronous 3 phase or 1 phase AC induction motor
- Integral motor protection
- Planetary gearbox in polymer or polymer / steel combination
- Low noise operation
- Light and distributed weight
- Maintenance free
- Lifetime lubrication
- Reversible operation
- Motorized Pulleys with RL greater than 21.65 inches have reinforced shaft

Applications

- Small conveyors for light loads, non-continuous use
- Transfer conveyors
- Packaging machines for light loads
- Metal detection, x-ray scanners
- Check stands in supermarkets
- Dry or humid applications

Technical data

| | |
|---|--|
| Type of motor | Asynchronous squirrel-cage, IEC 34 (VDE 0530) |
| Insulation class of motor windings | Class F, IEC 34 (VDE 0530) |
| Available power supplies* | 115v/1ph/60Hz, 230v/1ph/60Hz, 230v/3ph/60Hz, 460v/3ph/60Hz |
| Seal protection rating | IP66 |
| Thermal protection | Bimetallic contact |
| Allowable ambient temp., 3-ph motor | +41°F to + 104°F |
| Allowable ambient temp., 1-phase motor | +50° F to +104° F |
| Max. roller length (RL) | 35.91 in |

* Other power supply voltages and frequencies are available.



Motorized Pulley 80LP

Ø 3.37 in. (80 mm), planetary polymer gearbox



Materials

| Component | Version | Aluminum | Steel | Stainless Steel | Brass /Nickel |
|------------------------|---|----------|-------|-----------------|---------------|
| Shell | Crowned | Std | Opt | Opt | - |
| | Cylindrical | Opt | Opt | Opt | - |
| | Special crowns with grooves | Opt | Opt | Opt | - |
| End housing | Standard | Std | - | Opt | - |
| Shaft cap | Standard (with straight/90° free position cable) | Std | - | - | - |
| Electrical termination | Power cord with straight connector | - | - | Opt | Opt |
| | Power cord with 90° connector | - | - | Opt | Opt |
| | Power cord with elbow connector | Opt | - | Opt | - |

Options

- Dynamic balancing
- Food grade oil (EU, FDA and USDA)
- Non-horizontal mounting (more than $\pm 5^\circ$)
- For special versions, please contact RULMECA

Power Cord Specifications

- Standard, unshielded, 6 feet long
- Other types & lengths available upon request



Motorized Pulley 80LP

Ø 3.37 in. (80 mm), planetary polymer gearbox

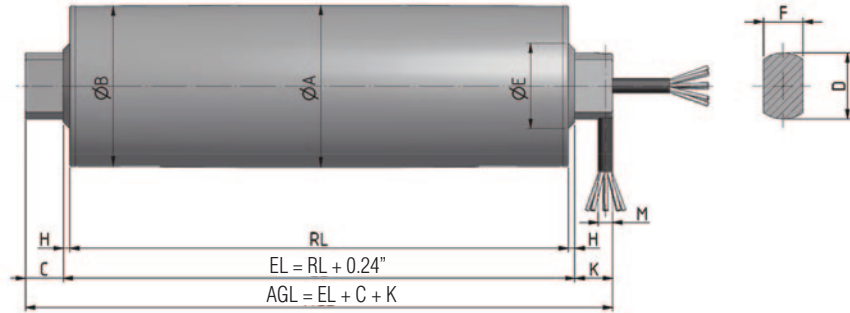

Motorized Pulley Standard Version.

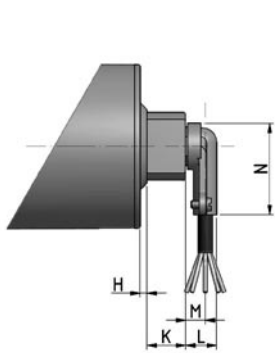

Elbow connector in aluminum.

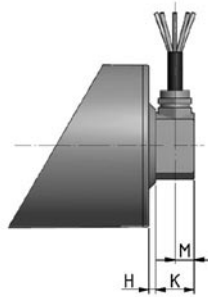

Cable connection 90°.

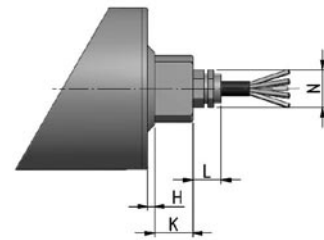

Straight connector.

| Type/Option | A in | B in | C in | D in | E in | F in | G in | H in | K in | L in | M in | N in | Q in | T in |
|--|------|------|------|------|------|------|------|------|------|------|------|------|------|------|
| Motorized Pulley Standard Version | 3.37 | 3.33 | 0.79 | 1.38 | 1.77 | 0.83 | | 0.12 | 0.79 | | 0.31 | | | |
| Elbow connector in aluminum | | | | | | | | | 0.79 | 0.71 | 0.47 | 1.89 | | |
| Cable connection 90 ° | | | | | | | | | 0.79 | | 0.39 | | | |
| Straight Connector | | | | | | | | | 0.79 | 0.59 | | 0.79 | | |

| | | | | | | | | | | | | | |
|-----------------------------------|-------|-------|-------|-------|-------|-------|-------|------|-------|-------|------|-------|-------|
| Std. RL shell lengths (in) | 11.81 | 13.78 | 15.75 | 17.72 | 19.69 | 21.65 | 23.62 | 25.6 | 27.56 | 29.53 | 31.5 | 33.46 | 35.43 |
| Avg. weight (lbs) | 9.5 | 10.0 | 10.5 | 11.0 | 11.0 | 11.5 | 12.0 | 17.0 | 17.5 | 18.0 | 19.0 | 20.0 | 20.5 |

- Min length: 9.96 in.
- Max length: 35.43 in
- Weights are approximate due to different shell executions and motor powers

Motorized Pulley 80LP

Ø 3.37 in. (80 mm), planetary polymer gearbox



| Power & Speed Combinations: 3 phase | | | | | | | | | | | | |
|-------------------------------------|-------|-------------------------|-----------------|------------|--|---|---------------|---|------------------------|-----|------------------------|--|
| Power HP | Poles | FLA (amps) ¹ | No. Gear Stages | Gear Ratio | Nominal belt speed at Full Load 60 Hz fpm ² | Actual belt speed at Full Load 60 Hz fpm ² | Belt Pull lbs | Max. Radial Load T1 + T2 lbs ³ | RL in | | | |
| 0.08 | 4 | 0.6/0.4 | 3 | 77.1 | 12 | 14 | 112* | 450 | min 10.59 max 35.43 | | | |
| | | | | 64.4 | 14 | 16 | 112* | | | | | |
| | | | | 54.5 | 18 | 20 | 112 | | | | | |
| | | | | 46.0 | 24 | 22 | 101 | | | | | |
| | | | | 43.7 | 26 | 24 | 92 | | | | | |
| | | | | 36.8 | 30 | 30 | 75 | | | | | |
| | | | | 35.0 | 35 | 32 | 70 | | | | | |
| | | | | 29.5 | 38 | 38 | 59 | | | | | |
| | | | 23.2 | 48 | 48 | 47 | | | | | | |
| | | | 2 | 14.2 | 76 | 78 | 29 | | min 9.96 max 35.43 | | | |
| 0.16 | 4 | 0.9/0.7 | 3 | 29.5 | 38 | 38 | 94* | 450 | min 11.50 max 35.43 | | | |
| | | | | 23.2 | 48 | 48 | 94 | | | | | |
| | | | 2 | 14.2 | 76 | 78 | 58 | | | 340 | min 10.87 max 35.43 | |
| | | | | 12.0 | 90 | 92 | 49 | | | | | |
| | | | | 11.3 | 96 | 98 | 46 | | | | | |
| | | | | | | | 9.5 | 120 | 118 | 38 | | |
| | | | | | | | 7.5 | 150 | 155 | 29 | | |

| Power & Speed Combinations: 1 phase | | | | | | | | | |
|-------------------------------------|-------|-------------------------|-----------------|------------|--|---|---------------|---|------------------------|
| Power HP | Poles | FLA (amps) ¹ | No. Gear Stages | Gear Ratio | Nominal belt speed at Full Load 60 Hz fpm ² | Actual belt speed at Full Load 60 Hz fpm ² | Belt Pull lbs | Max. Radial Load T1 + T2 lbs ³ | RL in |
| 0.08 | 4 | 0.05 | 3 | 77.1 | 12 | 14 | 112* | 450 | min 11.02 max 35.43 |
| | | | | 64.4 | 14 | 16 | 112* | | |
| | | | | 54.5 | 18 | 20 | 112 | | |
| | | | | 46.0 | 24 | 22 | 101 | | |
| | | | | 43.7 | 26 | 24 | 92 | | |
| | | | | 36.8 | 30 | 30 | 75 | | |
| | | | | 35.0 | 35 | 32 | 70 | | |
| | | | | 29.5 | 38 | 38 | 59 | | |
| | | | 23.2 | 48 | 48 | 47 | | | |
| | | | 2 | 14.2 | 76 | 78 | 29 | | min 10.59 max 35.43 |
| 0.1 | 4 | 0.07 | 3 | 36.8 | 30 | 30 | 90 | 450 | min 11.50 max 35.43 |
| | | | | 35.0 | 35 | 32 | 84 | | |
| | | | | 29.5 | 38 | 38 | 70 | | |
| | | | | 23.2 | 48 | 48 | 58 | | |
| | | | 2 | 14.2 | 76 | 78 | 36 | 340 | min 10.87 max 35.43 |
| | | | | 12.0 | 90 | 92 | 31 | | |
| | | | | 11.3 | 96 | 98 | 29 | | |
| | | | | 9.5 | 120 | 118 | 24 | | |

¹ FLA = full load amps at 230 volts & 460 volts (in 3 phase) and 230 volts (in 1 phase), respectively.

² Use "Nominal Speed" to specify pulley. "Actual belt speed" is presented (for unlagged pulley) to assist with process design calculations. See "Actual Speed vs Nominal Speed" section in Technical Precautions. Note that actual belt speed increases when lagging is used due to increased pulley diameter.

³ Pulley must not be subjected to radial load exceeding "Maximum Radial Load". See "Belt Tension" section in Technical Precautions.

* Note that belt pull is restricted in certain (slow speed) cases. Contact Rulmeca for more information.



Motorized Pulley 80LP

Ø 3.37 in. (80 mm), planetary polymer gearbox

Spare Parts List and Sectional Drawings

| | | | | | |
|----|---------------------|----|---------------------|----|-----------------------|
| 1 | Shaft cap (rear) | 14 | Wavey washer | 27 | Tywrap |
| 2 | Set screw | 15 | Flat washer | 28 | O-ring |
| 3 | Ball bearing | 16 | Planet gear (short) | 29 | Set screw |
| 4 | O-ring | 17 | Circlips | 30 | Compression seal |
| 5 | Oil seal | 18 | Ball bearing | 31 | Straight connector |
| 6 | Ring gear | 19 | Stator housing | 32 | End housing |
| 7 | Gear holder | 20 | Rotor | 33 | Shell |
| 8 | Roll pin | 21 | Stator | 34 | Shaft |
| 9 | Planet gear (long) | 22 | Stator housing | 35 | Rotor journal bearing |
| 10 | Planet gear (short) | 23 | Stator bolt | 36 | Rotor shaft |
| 11 | Sun gear (long) | 24 | Nut | 37 | Shaft cap (front) |
| 12 | Sun gear (short) | 25 | Rivet | 38 | Power cord |
| 13 | Gear carrier | 26 | Dowel pin | 39 | X-ring |

80LP Standard:

