

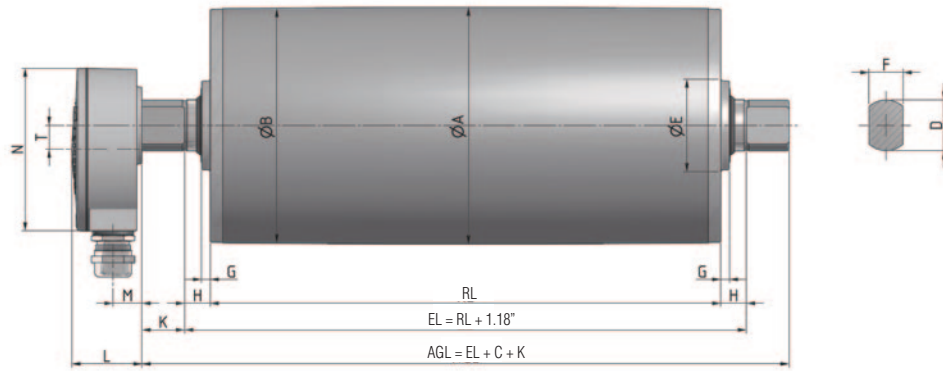

Motorized Pulley 138LS

Ø 5.45 in. (138 mm), helical steel gearbox



Standard Motorized Pulley with aluminum terminal box

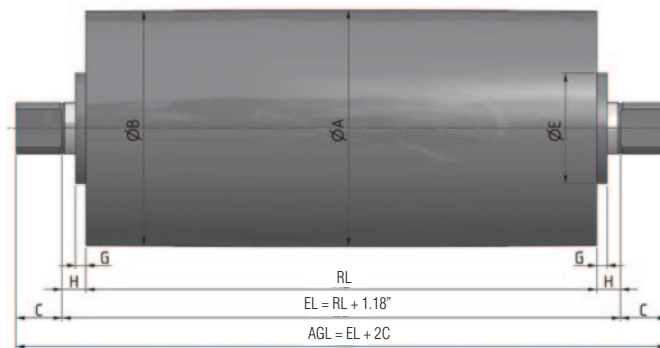

Idler Pulley in stainless steel

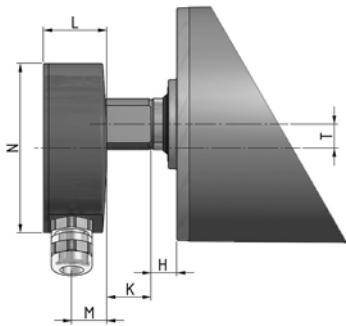

Terminal box in stainless steel.

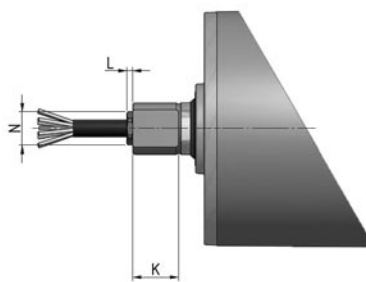

Straight connector in stainless steel.

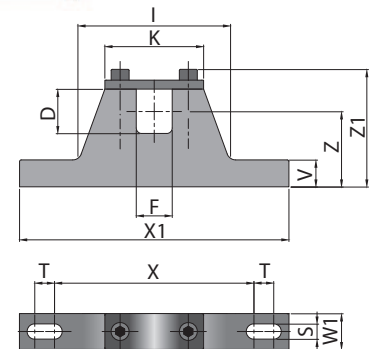

MC = Mounting bracket center-to-center spacing = $RL + 2.12''$

Mounting bracket

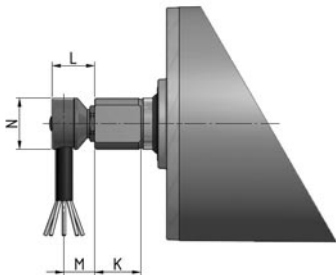

Elbow connector in stainless steel.

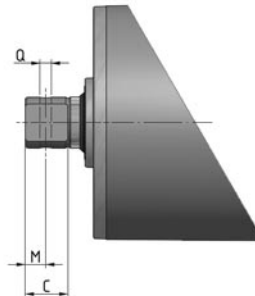

Shaft, cross-drilled and threaded.

Motorized Pulley 138LS

Ø 5.45 in. (138 mm), helical steel gearbox



Dimensions for Motorized Pulley 138LS

Type/Option	A in	B in	C in	D in	E in	F in	G in	H in	K in	L in	M in	N in	Q in	T in
Standard version with aluminum terminal box	5.45	5.39	0.98	1.18	2.13	0.79	0.20	0.59	0.98	1.61	0.67	3.74		0.55
Terminal box in stainless steel									0.98	1.46	0.81	3.90		0.55
Idler pulley in stainless steel					2.54		0.24		1.06					
Straight connector in stainless steel									1.06	0.14		0.77		
Elbow connector in stainless steel									1.06	0.94	0.71	1.18		
Cross-drilled and threaded shaft									1.06		0.47		M8	

Revised Dimensions for options

The following options increase the minimum roller length (RL)

Option	Optional RL min.
Electromagnetic brake	Standard RL min + 1.97in
Encoder - SKF	Standard RL min + 0 in
Encoder - RLS	Standard RL min +1.97in

Dimensions, materials, and weights for Mounting Brackets

Motorized Pulley	Standard Material	Optional Material	D in	F in	I in	K in	S in	T in	V in	W1 in	X in	X1 in	Z in	Z1 in	Thread	Wt lbs
138LS	Cast iron black powder coat	Stainless steel	1.18	0.79	3.39	2.24	0.43	0.67	0.47	0.94	4.33	7.09	1.75	2.83	M8	3.1

Standard weights for Motorized Pulley 138LS

Power HP	Poles	Standard weight [lbs] for standard RL [in]													
		11.81	12.60	13.78	15.75	17.72	19.69	21.65	23.62	25.59	27.56	29.53	31.50	35.43	39.37
0.13	12	31.0	32.0	33.0	35.0	37.5	39.5	42.0	44.0	47.5	50.5	53.0	55.0	59.5	64.0
0.25	8	31.0	32.0	33.0	35.0	37.5	39.5	42.0	44.0	47.5	50.5	53.0	55.0	59.5	64.0
0.32	6	31.0	32.0	33.0	35.0	37.5	39.5	42.0	44.0	47.5	50.5	53.0	55.0	59.5	64.0
0.50	6	---	33.0	34.5	36.5	38.5	41.0	43.0	45.0	48.5	52.0	54.0	56.0	60.5	65.0
	4	31.0	32.0	33.0	35.0	37.5	39.5	42.0	44.0	47.5	50.5	53.0	55.0	59.5	64.0
0.75	2	31.0	32.0	33.0	35.0	37.5	39.5	42.0	44.0	47.5	50.5	53.0	55.0	59.5	64.0
1.00	4	---	33.0	34.5	36.5	38.5	41.0	43.0	45.0	48.5	52.0	54.0	56.0	60.5	65.0
	2	31.0	32.0	33.0	35.0	37.5	39.5	42.0	44.0	47.5	50.5	53.0	55.0	59.5	64.0
1.34	2	---	---	36.5	38.5	41.0	43.0	45.0	47.4	50.5	54.0	56.0	58.5	63.0	67.0