



# 113LP-138LP Connection Diagrams

Power Cord (7 wire) - 1 Phase - Single Voltage - US Motor  
Internal Thermal Protection Switch not in series with motor

Code:

T1 & T2: Thermal protection

Cr: Run Capacitor

gn/ye - green yellow

**Low Voltage - Clockwise Rotation**

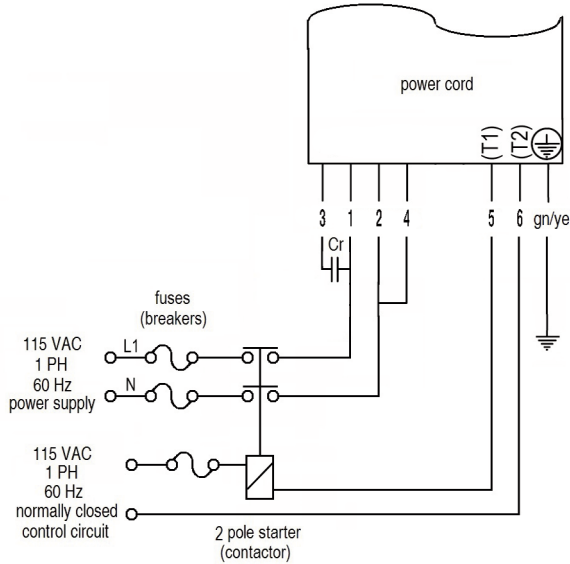

**Low Voltage - Counterclockwise Rotation**

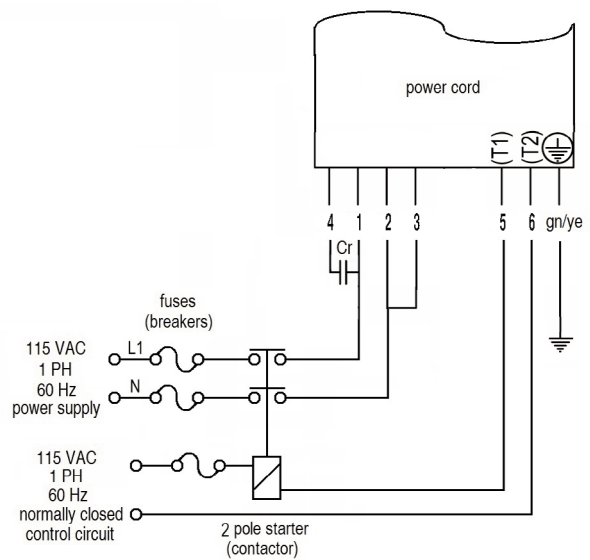

**High Voltage - Clockwise Rotation**

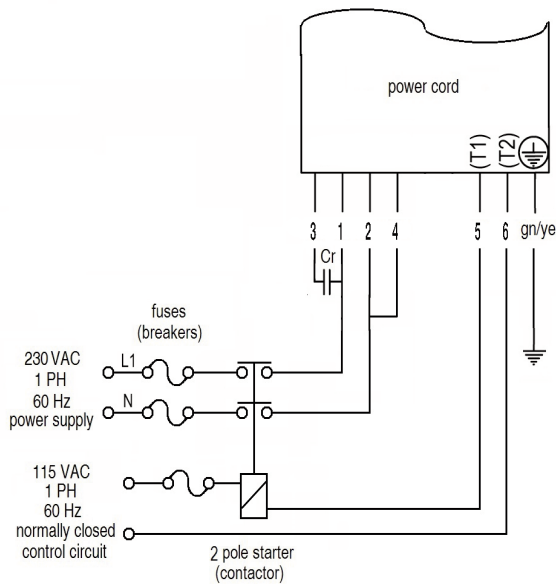

**High Voltage - Counterclockwise Rotation**

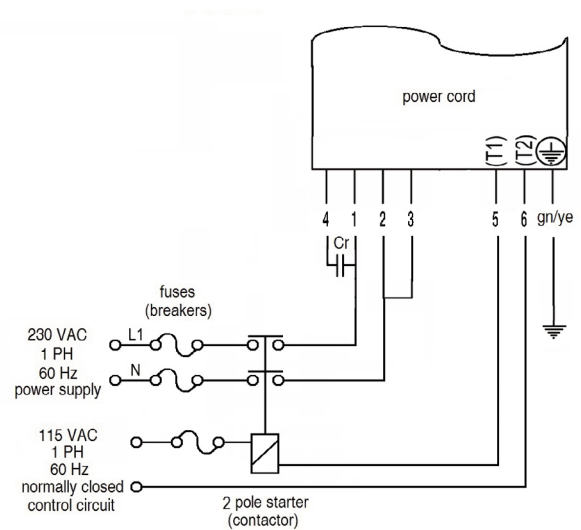

**NOTE:**

The thermal switch in this single phase motor is not installed in series with motor winding. Therefore, the switch must be connected to a normally closed control circuit to deactivate motor.